

Customer Information Sheet

DRAWING No.: R30-101XX02

SHEET 2 OF 2

IF IN DOUBT - ASK

©

NOT TO SCALE

THIRD ANGLE PROJECTION

ALL DIMENSIONS IN mm

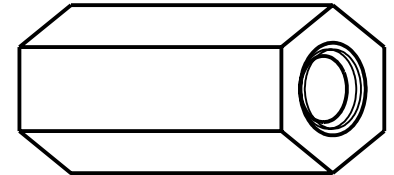
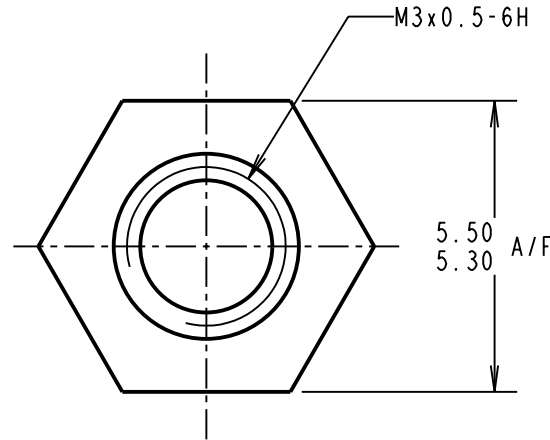
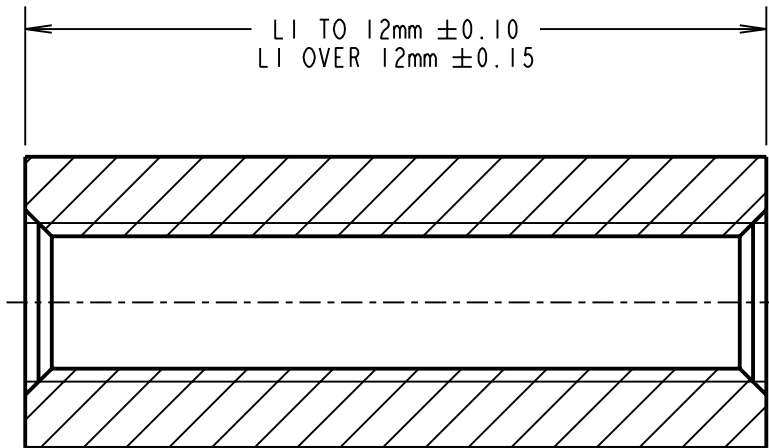

NOTES:

1. SPACERS OVER 22mm DO NOT HAVE A THROUGH TAPPED HOLE, BUT HAVE A MINIMUM THREAD LENGTH OF 10mm FROM BOTH ENDS.
2. FOR RS CODES SEE R6332B02 / R6338B02.

ORDER CODE:
R30-101XX02
LENGTH LI IN mm

PART No.	LI	PART No.	LI	PART No.	LI	PART No.	LI
R30-10104XX	4.00	R30-10111XX	11.00	R30-10118XX	18.00	R30-10125XX	25.00
R30-10105XX	5.00	R30-10112XX	12.00	R30-10119XX	19.00	R30-10126XX	26.00
R30-10106XX	6.00	R30-10113XX	13.00	R30-10120XX	20.00	R30-10127XX	27.00
R30-10107XX	7.00	R30-10114XX	14.00	R30-10121XX	21.00	R30-10128XX	28.00
R30-10108XX	8.00	R30-10115XX	15.00	R30-10122XX	22.00	R30-10129XX	29.00
R30-10109XX	9.00	R30-10116XX	16.00	R30-10123XX	23.00	R30-10130XX	30.00
R30-10110XX	10.00	R30-10117XX	17.00	R30-10124XX	24.00		

CP	7	04.03.10	10693
NAME	ISS.	DATE	C/NOTE
APPROVED: C. PENROSE			
CHECKED: R. ADDE			
DRAWN: A. LIOTTA			
CUSTOMER REF.:			
ASSEMBLY DRG:			

HARWIN

HARWIN USA TEL: 603 893 5376 FAX: 603 893 5396 mis@harwin.com	HARWIN Europe (UK) TEL: 023 9231 4545 FAX: 023 9231 4590 mis@harwin.co.uk	HARWIN Asia TEL: +65 6 779 4909 FAX: +65 6 779 3868 mis@harwin.com.sg
--	--	--

THIS DRAWING AND ANY INFORMATION OR DESCRIPTIVE MATTER SET OUT HEREON ARE CONFIDENTIAL AND COPYRIGHT PROPERTY OF THE HARWIN GROUP AND MUST NOT BE DISCLOSED, LOANED, COPIED, OR USED FOR MANUFACTURING, TENDERING OR FOR ANY OTHER PURPOSE WITHOUT THEIR WRITTEN PERMISSION.

TOLERANCES
X. = ± 1 mm
X.X = ± 0.25 mm
X.XX = ± 0.10 mm
X.XXX = ± 0.01 mm
ANGLES = $\pm 5^\circ$
UNLESS STATED

MATERIAL: BRASS
CW614N M TO BS EN 12164
(CuZn39Pb3)
FINISH: NICKEL
S/AREA: mm²

TITLE: M3 HEXAGONAL FEMALE SPACER
DRAWING NUMBER: **R30-101XX02**
SHT 2 OF 2