

# AZ9481

## 16 AMP LOW PROFILE POWER RELAY

### FEATURES

- High power switching (4000 VA)
- High sensitivity, 128 mW pickup
- Low profile (less than .5" height)
- SPST (1 Form A) and SPDT (1 Form C)
- UL Class F (155°C) standard
- Epoxy sealed versions available
- DC coils up to 48 VDC
- UL file E43203, TÜV R50053055



### CONTACTS

<b>Arrangement</b>	SPST (1 Form A) SPDT (1 Form C)
<b>Ratings</b>	<b>Resistive load:</b>
<b>Standard 1 Form A</b>	Max. switched power: 300 W, 2500 VA Max. switched current: 10 A Max. switched voltage: 250 VAC / 30 VDC
<b>High Capacity 1 Form A</b>	Max. switch power: 300 W, 4000 VA Max. switch current: 16 A Max. switched voltage: 250 VAC / 30 VDC
<b>1 Form C</b>	Max. switched power: 300 / 180 W, 2500 / 1500 VA (N.O./N.C.) Max. switched current: 10 / 6 A (N.O./N.C.) Max. switched voltages: 250 VAC / 30 VDC
<b>Rated Load UL</b>	Standard 1 Form A 10 A at 250 VAC Res. 100k cycles [1][2] 10 A at 30 VDC Res. 100k cycles [1][2] TV-5 [1][2]  High Capacity 1 Form A 16 A at 125 VAC Res. 100k cycles [1][2] 10 A at 30 VDC Res. 100k cycles [1][2] TV-5 [1][2]  Standard 1 Form C 10 / 6 A (N.O./N.C.) at 250 VAC Res. 100k cycles[2] 10 / 6 A (N.O./N.C.) at 250 VAC Res. 30k/100k cycles [3]
<b>TÜV</b>	High Capacity 1 Form A 16 A at 250 VAC Res. 100k cycles [1][2] 8 A at 250 VAC cos phi = 0.4 100k cycles [1][2] 10 A at 30 VDC Res. 100k cycles [1][2]
<b>Material</b>	Silver cadmium oxide [1], silver tin oxide [2] or silver nickel [3]. Gold plated contacts available.
<b>Resistance</b>	< 100 milliohms initially (6 V, 1 A voltage drop method)

### NOTES

1. All values at 20°C (68°F).
2. Relay may pull in with less than "Must Operate" value.
3. Specifications subject to change without notice.

### GENERAL DATA

<b>Life Expectancy</b> <b>Mechanical</b> <b>Electrical</b>	Minimum operations 1 x 10 <sup>7</sup> 1 x 10 <sup>5</sup> 10 A 250 VAC Res.
<b>Operate Time (typical)</b>	10 ms at nominal coil voltage
<b>Release Time (typical)</b>	5 ms at nominal coil voltage (with no coil suppression)
<b>Dielectric Strength</b> <b>(at sea level for 1 min.)</b>	2500 Vrms coil to contact 1000 Vrms contact to contact
<b>Insulation Resistance</b>	100 megohms min. at 20°C, 500 VDC, 50% RH
<b>Dropout</b>	Greater than 10% of nominal coil voltage
<b>Ambient Temperature</b> <b>Operating</b> <b>Storage</b>	At nominal coil voltage -40°C (-40°F) to 85°C (185°F) -40°C (-40°F) to 155°C (333°F)
<b>Vibration</b>	0.062" DA at 10–55 Hz
<b>Shock</b>	10g operational, 100g destructive
<b>Enclosure</b>	P.B.T. polyester
<b>Terminals</b>	Tinned copper alloy, P.C.
<b>Max. Solder Temp.</b>	270°C (518°F)
<b>Max. Solder Time</b>	5 seconds
<b>Max. Solvent Temp.</b>	80°C (176°F)
<b>Max. Immersion Time</b>	30 seconds
<b>Weight</b>	8 grams

### COIL

<b>Power</b>	
<b>At Pickup Voltage</b> <b>(typical)</b>	128 mW (Form A) 256 mW (Form C)
<b>Max. Continuous Dissipation</b>	1.34 W at 20°C (68°F)
<b>Temperature Rise</b>	24°C (43°F) at nominal coil voltage (Form C) 13°C (23°F) at nominal coil voltage (Form A)
<b>Temperature</b>	Max. 155°C (333°F)



**AMERICAN ZETTLER, INC.**

[www.azettler.com](http://www.azettler.com)

75 COLUMBIA • ALISO VIEJO, CA 92656 • PHONE: (949) 831-5000 • FAX: (949) 831-8642 • E-MAIL: SALES@AZETTLER.COM

12/14/05W

# AZ9481

## RELAY ORDERING DATA

COIL SPECIFICATIONS SPST-NO (1 Form A)				ORDER NUMBER*	
Nominal Coil VDC	Must Operate VDC	Max. Continuous VDC	Coil Resistance $\pm 10\%$	AgCdO Contacts	AgSnO <sub>2</sub> Contacts
5	4	13.4	125	AZ9481-1A-5D	AZ9481-1AE-5D
6	4.8	16.1	180	AZ9481-1A-6D	AZ9481-1AE-6D
9	7.2	24.1	405	AZ9481-1A-9D	AZ9481-1AE-9D
12	9.6	32.2	720	AZ9481-1A-12D	AZ9481-1AE-12D
18	14.4	48.3	1620	AZ9481-1A-18D	AZ9481-1AE-18D
24	19.2	64.4	2880	AZ9481-1A-24D	AZ9481-1AE-24D
48	38.4	128.8	11520	AZ9481-1A-48D	AZ9481-1AE-48D

\*Add suffix "E" for epoxy sealed version. Add suffix "A" for gold plated contacts.

COIL SPECIFICATIONS SPST-NO (1 Form A) - HIGH CAPACITY				ORDER NUMBER*	
Nominal Coil VDC	Must Operate VDC	Max. Continuous VDC	Coil Resistance $\pm 10\%$	AgCdO Contacts	AgSnO <sub>2</sub> Contacts
5	4	13.4	125	AZ9481-1AT-5D	AZ9481-1AET-5D
6	4.8	16.1	180	AZ9481-1AT-6D	AZ9481-1AET-6D
9	7.2	24.1	405	AZ9481-1AT-9D	AZ9481-1AET-9D
12	9.6	32.2	720	AZ9481-1AT-12D	AZ9481-1AET-12D
18	14.4	48.3	1620	AZ9481-1AT-18D	AZ9481-1AET-18D
24	19.2	64.4	2880	AZ9481-1AT-24D	AZ9481-1AET-24D
48	38.4	128.8	11520	AZ9481-1AT-48D	AZ9481-1AET-48D

\*Add suffix "E" for epoxy sealed version. Add suffix "A" for gold plated contacts.

COIL SPECIFICATIONS SPDT (1 Form C)				ORDER NUMBER*	
Nominal Coil VDC	Must Operate VDC	Max. Continuous VDC	Coil Resistance $\pm 10\%$	AgNi Contacts	AgSnO <sub>2</sub> Contacts
5	4	9.5	63	AZ9481-1CB-5D	AZ9481-1CE-5D
6	4.8	11.4	90	AZ9481-1CB-6D	AZ9481-1CE-6D
9	7.2	17.1	203	AZ9481-1CB-9D	AZ9481-1CE-9D
12	9.6	22.8	360	AZ9481-1CB-12D	AZ9481-1CE-12D
18	14.4	34.2	810	AZ9481-1CB-18D	AZ9481-1CE-18D
24	19.2	45.5	1440	AZ9481-1CB-24D	AZ9481-1CE-24D
48	38.4	91.1	5760	AZ9481-1CB-48D	AZ9481-1CE-48D

\*Add suffix "E" for epoxy sealed version. Add suffix "A" for gold plated contacts.



**AMERICAN ZETTLER, INC.**

[www.azettler.com](http://www.azettler.com)

75 COLUMBIA • ALISO VIEJO, CA 92656 • PHONE: (949) 831-5000 • FAX: (949) 831-8642 • E-MAIL: SALES@AZETTLER.COM

12/14/05W

# AZ9481

## MECHANICAL DATA

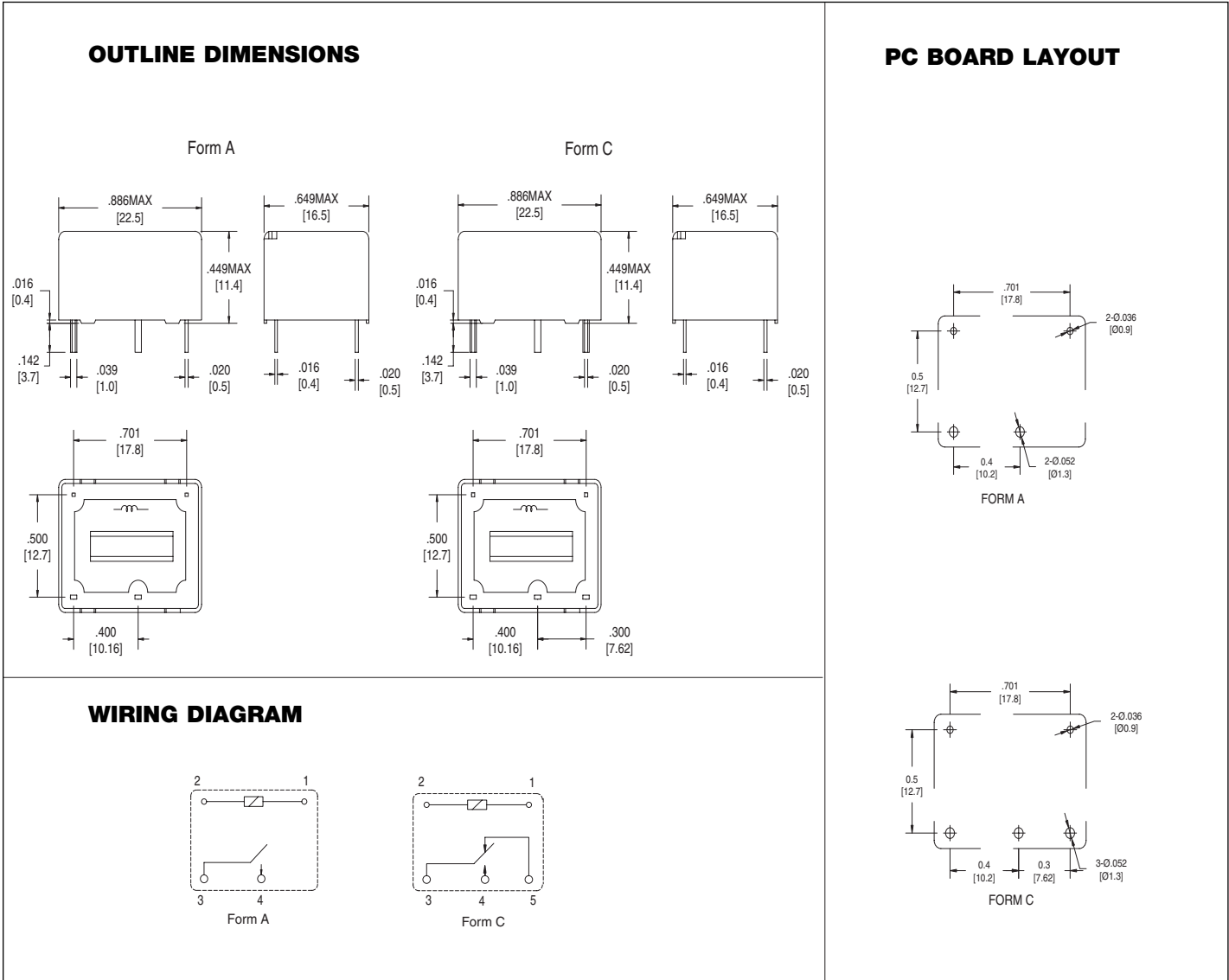

Dimensions in inch with millimeters in brackets below, Tolerance:  $\pm 0.010$ "



**AMERICAN ZETTLER, INC.**

[www.azettler.com](http://www.azettler.com)

75 COLUMBIA • ALISO VIEJO, CA 92656 • PHONE: (949) 831-5000 • FAX: (949) 831-8642 • E-MAIL: SALES@AZETTLER.COM

12/14/05W