



PMC131/PMS131/PMS130 Family 12-bit ADC Enhanced 8-bit Controller *Data Sheet*

Version 1.07 – Dec. 26, 2019

Copyright © 2019 by PADAUK Technology Co., Ltd., all rights reserved

6F-6, No.1, Sec. 3, Gongdao 5th Rd., Hsinchu City 30069, Taiwan, R.O.C.

TEL: 886-3-572-8688  www.padauk.com.tw

IMPORTANT NOTICE

PADAUK Technology reserves the right to make changes to its products or to terminate production of its products at any time without notice. Customers are strongly recommended to contact PADAUK Technology for the latest information and verify whether the information is correct and complete before placing orders.

PADAUK Technology products are not warranted to be suitable for use in life-support applications or other critical applications. PADAUK Technology assumes no liability for such applications. Critical applications include, but are not limited to, those which may involve potential risks of death, personal injury, fire or severe property damage.

PADAUK Technology assumes no responsibility for any issue caused by a customer's product design. Customers should design and verify their products within the ranges guaranteed by PADAUK Technology. In order to minimize the risks in customers' products, customers should design a product with adequate operating safeguards.

Table of content

1. Features	8
1.1. Special Features	8
1.2. System Features	8
1.3. CPU Features	9
1.4. Package Information:	9
2. General Description and Block Diagram	10
3. PMC131/PMS131/PMS130 Family and Pin Description	11
4. Device Characteristics	17
4.1. AC/DC Device Characteristics	17
4.2. Absolute Maximum Ratings.....	19
4.3. Typical ILRC frequency vs. VDD and temperature	20
4.4. Typical IHRC frequency deviation vs. VDD (calibrated to 16MHz).....	20
4.5. Typical ILRC Frequency vs. Temperature	21
4.6. Typical IHRC Frequency vs. Temperature (calibrated to 16MHz).....	21
4.7. Typical operating current vs. VDD @ system clock = ILRC/n	22
4.8. Typical operating current vs. VDD @ system clock = IHRC/n	22
4.9. Typical operating current vs. VDD @ system clock = 4MHz EOSC / n	23
4.10. Typical operating current vs. VDD @ system clock = 32kHz EOSC / n	23
4.11. Typical operating current vs. VDD @ system clock = 1MHz EOSC / n	24
4.12. Typical IO driving current (I_{OH}) and sink current (I_{OL})	24
4.13. Typical IO input high/low threshold voltage (V_{IH}/V_{IL})	25
4.14. Typical resistance of IO pull high device	25
4.15. Typical power down current (I_{PD}) and power save current (I_{PS}).....	26
5. Functional Description	27
5.1. Program Memory -- OTP.....	27
5.2. Boot Procedure	27
5.2.1. Timing charts for reset conditions	28
5.3. Data Memory - SRAM.....	29
5.4. Oscillator and clock.....	29
5.4.1. Internal High RC oscillator and Internal Low RC oscillator	29
5.4.2. Chip calibration.....	29
5.4.3. IHRC Frequency Calibration and System Clock	29

5.4.4.	External Crystal Oscillator	31
5.4.5.	System Clock and LVR level	33
5.4.6.	System Clock Switching	34
5.5.	16-bit Timer (Timer16)	35
5.6.	8-bit Timer (Timer2/Timer3) with PWM generation	37
5.6.1.	Using the Timer2 to generate periodical waveform	38
5.6.2.	Using the Timer2 to generate 8-bit PWM waveform.....	40
5.6.3.	Using the Timer2 to generate 6-bit PWM waveform.....	41
5.7.	WatchDog Timer	42
5.8.	Interrupt	43
5.9.	Power-Save and Power-Down	46
5.9.1.	Power-Save mode (“stopexe”).....	46
5.9.2.	Power-Down mode (“stopsys”)	47
5.9.3.	Wake-up.....	48
5.10.	IO Pins.....	49
5.11.	Reset and LVR.....	50
5.11.1.	Reset.....	50
5.11.2.	LVR reset	50
5.12.	Analog-to-Digital Conversion (ADC) module	50
5.12.1.	The input requirement for AD conversion	51
5.12.2.	Select the ADC bit resolution.....	52
5.12.3.	Select the reference high voltage	52
5.12.4.	ADC clock selection.....	52
5.12.5.	AD conversion	53
5.12.6.	Configure the analog pins.....	53
5.12.7.	Using the ADC.....	53
5.13.	Multiplier	54
6.	IO Registers	55
6.1.	ACC Status Flag Register (<i>flag</i>), IO address = 0x00	55
6.2.	Stack Pointer Register (<i>sp</i>), IO address = 0x02	55
6.3.	Clock Mode Register (<i>clkmd</i>), IO address = 0x03	55
6.4.	Interrupt Enable Register (<i>inten</i>), IO address = 0x04	56
6.5.	Interrupt Request Register (<i>intrq</i>), IO address = 0x05	56
6.6.	Multiplier Operand Register (<i>mulop</i>), IO address = 0x08.....	56
6.7.	Multiplier Result High Byte Register (<i>mulrh</i>), IO address = 0x09	56
6.8.	Timer16 mode Register (<i>t16m</i>), IO address = 0x06.....	57
6.9.	External Oscillator setting Register (<i>eoscr</i>), IO address = 0x0a.....	57

6.10.	Interrupt Edge Select Register (<i>integs</i>), IO address = 0x0c.....	58
6.11.	Port A Digital Input Enable Register (<i>padier</i>), IO address = 0x0d.....	58
6.12.	Port B Digital Input Enable Register (<i>pbdier</i>), IO address = 0x0e.....	59
6.13.	Port A Data Register (<i>pa</i>), IO address = 0x10.....	59
6.14.	Port A Control Register (<i>pac</i>), IO address = 0x11.....	59
6.15.	Port A Pull-High Register (<i>paph</i>), IO address = 0x12.....	59
6.16.	Port B Data Register (<i>pb</i>), IO address = 0x14.....	59
6.17.	Port B Control Register (<i>pbcb</i>), IO address = 0x15.....	59
6.18.	Port B Pull-High Register (<i>pbph</i>), IO address = 0x16.....	60
6.19.	ADC Control Register (<i>adcc</i>), IO address = 0x20.....	60
6.20.	ADC Regulator Control Register (<i>adcrhc</i>), IO address = 0x1c.....	60
6.21.	ADC Mode Register (<i>adcm</i>), IO address = 0x21.....	61
6.22.	ADC Result High Register (<i>adcrh</i>), IO address = 0x22.....	61
6.23.	ADC Result Low Register (<i>adcrll</i>), IO address = 0x23.....	61
6.24.	Miscellaneous Register (<i>misc</i>), IO address = 0x1b.....	62
6.25.	Timer2 Control Register (<i>tm2c</i>), IO address = 0x3c.....	63
6.26.	Timer2 Counter Register (<i>tm2ct</i>), IO address = 0x3d.....	63
6.27.	Timer2 Scalar Register (<i>tm2s</i>), IO address = 0x37.....	63
6.28.	Timer2 Bound Register (<i>tm2b</i>), IO address = 0x09.....	64
6.29.	Timer3 Control Register (<i>tm3c</i>), IO address = 0x2e.....	64
6.30.	Timer3 Counter Register (<i>tm3ct</i>), IO address = 0x2f.....	64
6.31.	Timer3 Scalar Register (<i>tm3s</i>), IO address = 0x39.....	65
6.32.	Timer3 Bound Register (<i>tm3b</i>), IO address = 0x23.....	65
6.33.	RESET Status Register (<i>rstst</i>), IO address = 0x25.....	65
7.	Instructions.....	66
7.1.	Data Transfer Instructions.....	67
7.2.	Arithmetic Operation Instructions.....	69
7.3.	Shift Operation Instructions.....	71
7.4.	Logic Operation Instructions.....	72
7.5.	Bit Operation Instructions.....	74
7.6.	Conditional Operation Instructions.....	75
7.7.	System control Instructions.....	77
7.8.	Summary of Instructions Execution Cycle.....	78
7.9.	Summary of affected flags by Instructions.....	79
7.10.	RAM definition.....	79
8.	Code Options.....	80
9.	Special Notes.....	81

9.1.	Warning	81
9.2.	Using IC	81
9.2.1.	IO pin usage and setting	81
9.2.2.	Interrupt	83
9.2.3.	System clock switching	83
9.2.4.	Power down mode, wakeup and watchdog	84
9.2.5.	TIMER16 time out	85
9.2.6.	IHRC	85
9.2.7.	LVR	85
9.2.8.	Programming the PMC131/PMS131/PMS130	86
9.3.	Using ICE	86

Revision History:

Revision	Date	Description
0.01	2013/12/02	1 st version
0.02	2014/02/17	Add chapter 8 Special Notes
0.03	2014/06/10	Add (7) in section 8.1.1: Notice of using the PB3
0.04	2014/12/22	Amend PMS 131/PMS130 operating temperature
0.05	2015/06/17	<ol style="list-style-type: none"> 1. Amend PMS131/PMS130 operating temperature range to -20°C ~ 70°C 2. Amend 4.1 Band-gap reference voltage
1.06	2018/11/07	<ol style="list-style-type: none"> 1. Updated company address & Tel No. 2. Amend Section 1.1 Special Features 3. Amend Section 1.4 Package Information 4. Add Chapter 3 Pin Assignment and Description: PMC131-S08A, PMC131-D08A, PMC131-S08B, PMC131-D08B, PMC131-U06, PMS131-S08, PMS130-S08, PMS130-D08, PMS130-U06 5. Add AVDD and AGND in Chapter 3 6. Amend 4.7 Typical operating current vs. VDD @ system clock = ILRC/n 7. Amend 4.8 Typical operating current vs. VDD @ system clock = IHRC/n 8. Amend 4.9 Typical operating current vs. VDD @ system clock = 4MHz EOSC / n 9. Amend 4.10 Typical operating current vs. VDD @ system clock = 32kHz EOSC / n 10. Amend 4.11 Typical operating current vs. VDD @ system clock = 1MHz EOSC / n 11. Amend 4.12 Typical IO driving current (IOH) and sink current (IOL) 12. Amend 4.13 Typical IO input high/low threshold voltage (VIH/VIL) 13. Amend 4.14 Typical resistance of IO pull high device 14. Add 4.15 Timing charts for boot up conditions 15. Amend Table 2: Three oscillation circuits 16. Amend 5.4.3 IHRC Frequency Calibration and System Clock 17. Amend 5.4.5 System Clock and LVR level 18. Amend 5.5 16-bit Timer 19. Amend 5.6 8-bit Timer (Timer2/Timer3) with PWM generation 20. Amend 5.8 Interrupt 21. Amend 5.9.1 Power-Save mode 22. Amend 5.9.2 Power-Down mode 23. Amend 5.11.1 Reset 24. Amend Fig. 13 25. Amend 5.12.7 Using ADC 26. Amend 6.11 Port A Digital Input Enable Register 27. Amend 6.12 Port B Digital Input Enable Register 28. Add Chapter 8 Code options 29. Add 9.1 Warning 30. Amend 9.2.1 IO pin usage and setting 31. Amend 9.2.6 IHRC 32. Amend 9.2.7 LVR 33. Move 9.2.9 RAM definition to 7.10 34. Amend 9.2.9 Programming the PMC131/PMS131/PMS130 35. Amend 9.3 Using ICE
1.07	2019/12/26	<ol style="list-style-type: none"> 1. Amend 1.2, 4.3, 4.4, 4.5, 4.6, 4.9, 4.10, 4.11, 5.6, 5.6.1, 5.6.2, 5.6.3, 5.9.1, 5.9.3, 5.12.7, 6.3, 6.11, 6.12, 6.33, 9.2.8 2. Amend 4.1: V_{IL}, t_{WDT} 3. Delete 4.16 and add 5.2.1 4. Amend Fig. 10 5. Amend Chapter 3 and Chapter 8 6. Delete 9.2.8: additional functions

1. Features

1.1. Special Features

- ◆ PMC131 series:
 - ◇ High EFT series
 - ◇ Operating temperature range: -40°C ~ 85°C
- ◆ PMS131, PMS130 series:
 - ◇ General purpose series
 - ◇ Not supposed to use in AC RC step-down powered or high EFT requirement applications.
PADAUK assumes no liability if such kind of applications can not pass the safety regulation tests.
 - ◇ Operating temperature range: -20°C ~ 70°C

1.2. System Features

- ◆ 1.5KW OTP program memory
- ◆ 88 Bytes data RAM
- ◆ One hardware 16-bit timer
- ◆ Two hardware 8-bit timers with PWM generation
- ◆ Provide 1T 8x8 hardware multiplier
- ◆ Support fast wake-up
- ◆ 14 IO pins
- ◆ Every IO pin can be configured to enable wake-up function
- ◆ Band-gap circuit to provide 1.20V reference voltage, including 1 channel from internal band-gap reference voltage or $0.24 \cdot V_{DD}$
- ◆ Up to 12-channel 12-bit resolution ADC
- ◆ Operating voltage range: 2.2V ~ 5.5V
- ◆ Operating frequency and voltage for both crystal mode and IHRC mode
DC ~ 8MHz@ $V_{DD} \geq 3.1V$ DC ~ 4MHz@ $V_{DD} \geq 2.5V$ DC ~ 2MHz@ $V_{DD} \geq 2.2V$
- ◆ Provide ADC reference high voltage: external input, internal V_{DD} , Band-gap 1.20V, 4V, 3V, 2V
- ◆ Clock sources: internal high RC oscillator, internal low RC oscillator and external crystal oscillator
- ◆ Eight levels of LVR reset: 4.1V, 3.6V, 3.1V, 2.8V, 2.5V, 2.2V, 2.0V, 1.8V
- ◆ Four selectable external interrupt pins

1.3. CPU Features

- ◆ One processing unit operating mode
- ◆ 86 powerful instructions
- ◆ Most instructions are 1T execution cycle
- ◆ Programmable stack pointer to provide adjustable stack level
- ◆ Direct and indirect addressing modes for data and instructions
- ◆ Direct and indirect addressing modes for data access. Data memories are available for use as an index pointer of Indirect addressing mode
- ◆ IO space and memory space are independent

1.4. Package Information:

◆ **PMC131 series**

- ◇ PMC131-S16A: SOP16 (150mil);
- ◇ PMC131-S16B: SOP16 (150mil);
- ◇ PMC131-D16A: DIP16 (300mil);
- ◇ PMC131-D16B: DIP16 (300mil);
- ◇ PMC131-S14: SOP14 (150mil);
- ◇ PMC131-D14: DIP14 (300mil);
- ◇ PMC131-M10: MSOP10 (118mil);
- ◇ PMC131-S08A: SOP8 (150mil);
- ◇ PMC131-S08B: SOP8 (150mil);
- ◇ PMC131-D08A: DIP8 (300mil);
- ◇ PMC131-D08B: DIP8 (300mil);
- ◇ PMC131-U06: SOT23-6 (60mil)

◆ **PMS131 series**

- ◇ PMS131-S16: SOP16 (150mil);
- ◇ PMS131-D16: DIP16 (300mil);
- ◇ PMS131-S14: SOP14 (150mil);
- ◇ PMS131-D14: DIP14 (300mil);
- ◇ PMS131-S08: SOP8 (150mil)

◆ **PMS130 series**

- ◇ PMS130-M10: MSOP10 (118mil);
- ◇ PMS130-S08: SOP8 (150mil);
- ◇ PMS130-D08: DIP8 (300mil);
- ◇ PMS130-U06: SOT23-6 (60mil)

2. General Description and Block Diagram

The PMC131/PMS131/PMS130 family is an ADC-Type, fully static, OTP-based CMOS 8-bit microcontroller. It employs RISC architecture and all the instructions are executed in one cycle except that some instructions are two cycles that handle indirect memory access.

1.5KW bits OTP program memory and 88 bytes data SRAM are inside, one up to 12 channels 12-bit ADC is built inside the chip with one channel for internal band-gap reference voltage or $0.24 \cdot V_{DD}$. PMC131/PMS131/PMS130 also provides three hardware timers: one is 16-bit timer and the other two are 8-bit timers with PWM generation.

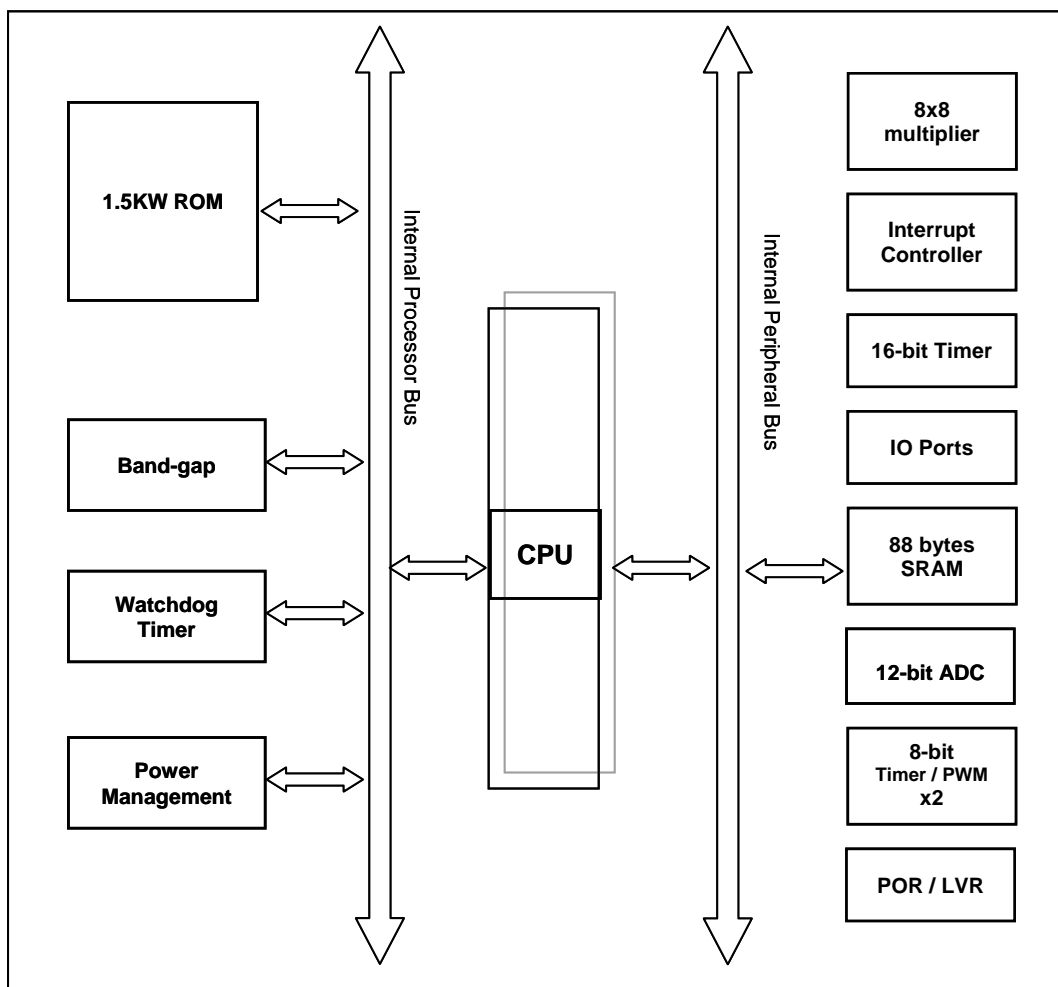

3. PMC131/PMS131/PMS130 Family and Pin Description

◆ PMC131 series

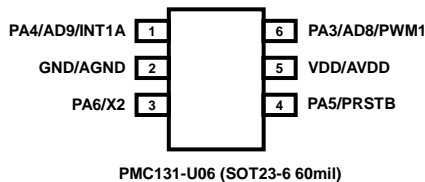
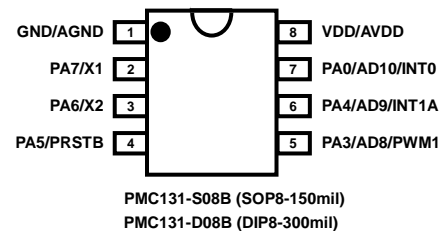
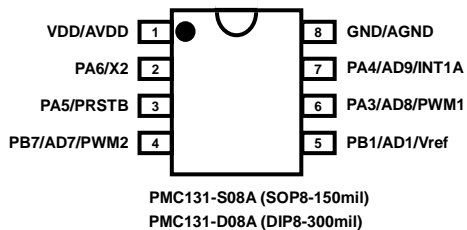
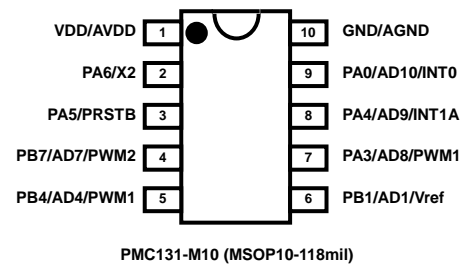
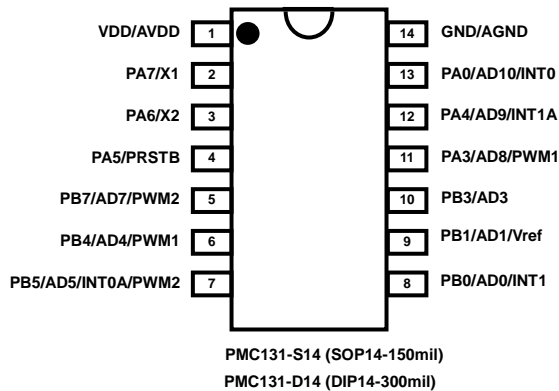
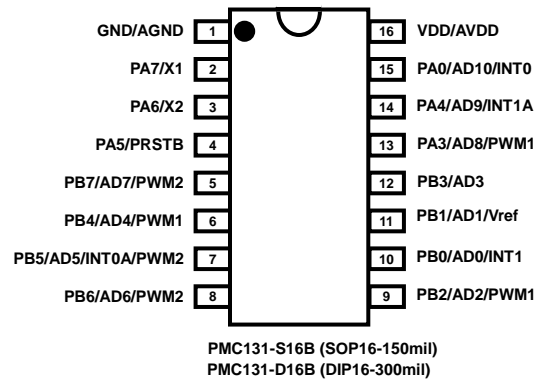
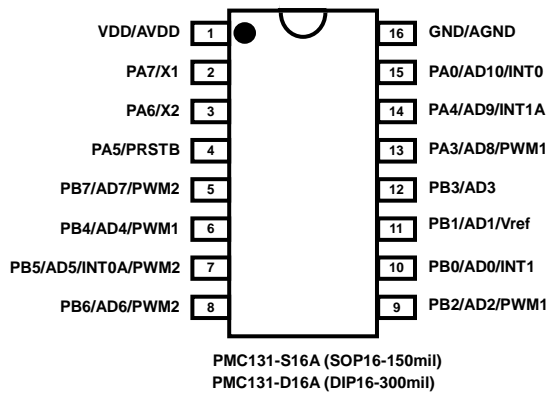

◆ PMS131/PMS130 series

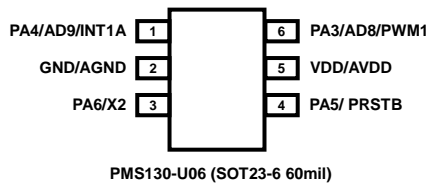
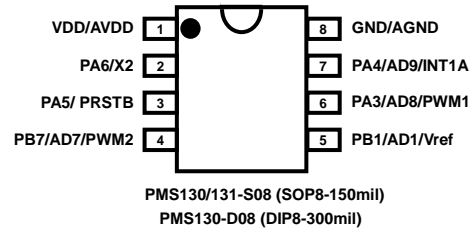
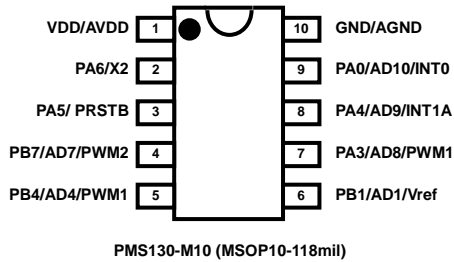
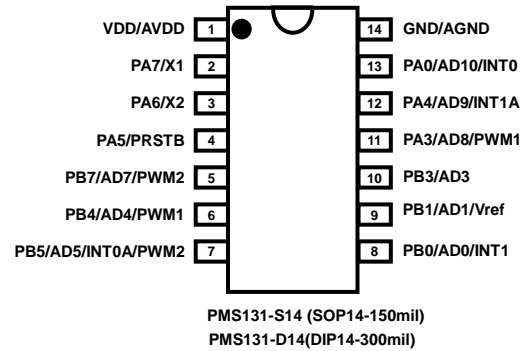
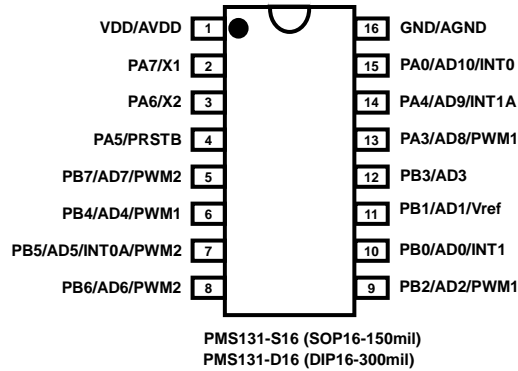

Pin Description

Pin Name	Pin Type & Buffer Type	Description
PA7 / X1	IO ST / CMOS	<p>The functions of this pin can be:</p> <p>(1) Bit 7 of port A. It can be configured as digital input or two-state output, with pull-up resistor.</p> <p>(2) X1 when crystal oscillator is used.</p> <p>If this pin is used for crystal oscillator, bit 7 of padier register must be programmed "0" to avoid leakage current. This pin can be used to wake-up system during sleep mode; however, wake-up function is also disabled if bit 7 of padier register is "0".</p>
PA6 / X2	IO ST / CMOS	<p>The functions of this pin can be:</p> <p>(1) Bit 6 of port A. It can be configured as digital input or two-state output, with pull-up resistor.</p> <p>(2) X2 when crystal oscillator is used.</p> <p>If this pin is used for crystal oscillator, bit 6 of padier register must be programmed "0" to avoid leakage current. This pin can be used to wake-up system during sleep mode; however, wake-up function is also disabled if bit 6 of padier register is "0".</p>
PA5 / PRSTB	IO (OD) ST / CMOS	<p>The functions of this pin can be:</p> <p>(1) Bit 5 of port A. It can be configured as digital input or open-drain output.</p> <p>(2) Hardware reset.</p> <p><u>Please note that PA5 does NOT have pull-up resistor.</u></p> <p>This pin can be used to wake-up system during sleep mode; however, wake-up function is also disabled if bit 5 of padier register is "0". <u>Please put 33Ω resistor in series to have high noise immunity when this pin is in input mode.</u></p>
PA4 / AD9 / INT1A	IO ST / CMOS / Analog	<p>The functions of this pin can be:</p> <p>(1) Bit 4 of port A. It can be configured as digital input or two-state output, with pull-up resistor by software independently.</p> <p>(2) Channel 9 of ADC analog input</p> <p>(3) External interrupt line 1A. It can be used as an external interrupt line 1. <u>Both rising edge and falling edge are accepted to request interrupt service and configurable by register setting</u></p> <p>When this pin is configured as analog input, please use bit 4 of register padier to disable the digital input to prevent current leakage. The bit 4 of padier register can be set to "0" to disable digital input; wake-up from power-down by toggling this pin is also disabled.</p>
PA3 / AD8 / PWM1	IO ST / CMOS / Analog	<p>The functions of this pin can be:</p> <p>(1) Bit 3 of port A. It can be configured as digital input or two-state output, with pull-up resistor by software independently.</p> <p>(2) Channel 8 of ADC analog input</p> <p>(3) PWM output from Timer2</p> <p>When this pin is configured as analog input, please use bit 3 of register padier to disable the digital input to prevent current leakage. The bit 3 of padier register can be set to "0" to disable digital input; wake-up from power-down by toggling this pin is also disabled.</p>

Pin Name	Pin Type & Buffer Type	Description
PA0 / AD10 / INT0	IO ST / CMOS / Analog	<p>The functions of this pin can be:</p> <ol style="list-style-type: none"> Bit 0 of port A. It can be configured as digital input or two-state output, with pull-up resistor by software independently. Channel 10 of ADC analog input External interrupt line 0. It can be used as an external interrupt line 0. <u>Both rising edge and falling edge are accepted to request interrupt service and configurable by register setting.</u> <p>The bit 0 of padier register can be set to “0” to disable wake-up from power-down by toggling this pin.</p>
PB7 / AD7 / PWM2	IO ST / CMOS / Analog	<p>The functions of this pin can be:</p> <ol style="list-style-type: none"> Bit 7 of port B. It can be configured as digital input or two-state output, with pull-up resistor by software independently. Channel 7 of ADC analog input PWM output from Timer3 <p>When this pin is configured as analog input, please use bit 7 of register pbdierr to disable the digital input to prevent current leakage. The bit 7 of pbdierr register can be set to “0” to disable digital input; wake-up from power-down by toggling this pin is also disabled.</p>
PB6 / AD6 / PWM2	IO ST / CMOS / Analog	<p>The functions of this pin can be:</p> <ol style="list-style-type: none"> Bit 6 of port B. It can be configured as digital input or two-state output, with pull-up resistor by software independently. Channel 6 of ADC analog input PWM output from Timer3 <p>When this pin is configured as analog input, please use bit 6 of register pbdierr to disable the digital input to prevent current leakage. The bit 6 of pbdierr register can be set to “0” to disable digital input; wake-up from power-down by toggling this pin is also disabled.</p>
PB5 / AD5 / INT0A / PWM2	IO ST / CMOS / Analog	<p>The functions of this pin can be:</p> <ol style="list-style-type: none"> Bit 5 of port B. It can be configured as digital input or two-state output, with pull-up resistor by software independently. Channel 5 of ADC analog input External interrupt line 0A. It can be used as an external interrupt line 0. <u>Both rising edge and falling edge are accepted to request interrupt service and configurable by register setting.</u> PWM output from Timer3 <p>When this pin is configured as analog input, please use bit 5 of register pbdierr to disable the digital input to prevent current leakage. The bit 5 of pbdierr register can be set to “0” to disable digital input; wake-up from power-down by toggling this pin is also disabled.</p>

Pin Name	Pin Type & Buffer Type	Description
PB4 / AD4 / PWM1	IO ST / CMOS / Analog	<p>The functions of this pin can be:</p> <ul style="list-style-type: none"> (1) Bit 4 of port B. It can be configured as digital input or two-state output, with pull-up resistor by software independently. (2) Channel 4 of ADC analog input (3) PWM output from Timer2 <p>When this pin is configured as analog input, please use bit 4 of register <i>pbdier</i> to disable the digital input to prevent current leakage. The bit 4 of <i>pbdier</i> register can be set to “0” to disable digital input; wake-up from power-down by toggling this pin is also disabled.</p>
PB3 / AD3	IO ST / CMOS / Analog	<p>The functions of this pin can be:</p> <ul style="list-style-type: none"> (1) Bit 3 of port B. It can be configured as digital input or two-state output, with pull-up resistor by software independently. (2) Channel 3 of ADC analog input <p>When this pin is configured as analog input, please use bit 3 of register <i>pbdier</i> to disable the digital input to prevent current leakage. The bit 3 of <i>pbdier</i> register can be set to “0” to disable digital input; wake-up from power-down by toggling this pin is also disabled.</p>
PB2 / AD2 / PWM1	IO ST / CMOS / Analog	<p>The functions of this pin can be:</p> <ul style="list-style-type: none"> (1) Bit 2 of port B. It can be configured as digital input or two-state output, with pull-up resistor by software independently. (2) Channel 2 of ADC analog input (3) PWM output from Timer2 <p>When this pin is configured as analog input, please use bit 2 of register <i>pbdier</i> to disable the digital input to prevent current leakage. The bit 2 of <i>pbdier</i> register can be set to “0” to disable digital input; wake-up from power-down by toggling this pin is also disabled.</p>
PB1 / AD1 / Vref	IO ST / CMOS / Analog	<p>The functions of this pin can be:</p> <ul style="list-style-type: none"> (1) Bit 1 of port B. It can be configured as digital input or two-state output, with pull-up resistor by software independently. (2) Channel 1 of ADC analog input (3) External reference high voltage for ADC. <p>When this pin is configured as analog input, please use bit 1 of register <i>pbdier</i> to disable the digital input to prevent current leakage. The bit 1 of <i>pbdier</i> register can be set to “0” to disable digital input; wake-up from power-down by toggling this pin is also disabled.</p>

Pin Name	Pin Type & Buffer Type	Description
PB0 / AD0 / INT1	IO ST / CMOS / Analog	<p>The functions of this pin can be:</p> <p>(1) Bit 0 of port B. It can be configured as digital input or two-state output, with pull-up resistor by software independently.</p> <p>(2) Channel 0 of ADC analog input. When this pin acts as analog input, please use bit 0 of register <i>pbdier</i> to disable the digital input to prevent current leakage.</p> <p>(3) External interrupt line 1. It can be used as an external interrupt line 1. <u>Both rising edge and falling edge are accepted to request interrupt service and configurable by register setting.</u></p> <p>If bit 0 of <i>pbdier</i> register is set to "0" to disable digital input, wake-up from power-down by toggling this pin is also disabled.</p>
VDD / AVDD	VDD / AVDD	<p>VDD: Digital positive power</p> <p>AVDD: Analog positive power</p> <p>VDD is the IC power supply while AVDD is the ADC power supply. AVDD and VDD are double bonding internally and they have the same external pin.</p>
GND / AGND	GND / AGND	<p>GND: Digital negative power</p> <p>AGND: Analog negative power</p> <p>GND is the IC ground pin while AGND is the ADC ground pin. AGND and GND are double bonding internally and they have the same external pin.</p>
<p>Notes: IO: Input/Output; ST: Schmitt Trigger input; OD: Open Drain; Analog: Analog input pin; CMOS: CMOS voltage level</p>		

4. Device Characteristics

4.1. AC/DC Device Characteristics

All data are acquired under the conditions of $V_{DD}=5.0V$, $f_{SYS}=2MHz$ unless noted.

Symbol	Description	Min	Typ	Max	Unit	Conditions (Ta=25°C)
V_{DD}	Operating Voltage	2.2	5.0	5.5	V	
f_{SYS}	System clock (CLK)* =					Under_20ms_VDD_ok** = Y/N $V_{DD} \geq 2.5V / V_{DD} \geq 3.1V$ $V_{DD} \geq 2.2V / V_{DD} \geq 2.5V$ $V_{DD} \geq 2.2V / V_{DD} \geq 2.2V$ $V_{DD}=5.0V$
	IHRC/2	0		8M	Hz	
	IHRC/4	0		4M		
	IHRC/8	0		2M		
	ILRC		37K			
I_{OP}	Operating Current		1.7		mA	$f_{SYS}=IHRC/16=1MIPS@5.0V$ $f_{SYS}=ILRC=21kHz@3.3V$
			15		uA	
I_{PD}	Power Down Current (by stopsys command)		2.0		uA	$f_{SYS}=0Hz, V_{DD}=5.0V$ $f_{SYS}=0Hz, V_{DD}=3.3V$
			1.0		uA	
I_{PS}	Power Save Current (by stopexe command)		0.3		mA	$V_{DD}=5.0V$; Band-gap, LVR, IHRC, ILRC, Timer16 modules are ON.
V_{IL}	Input low voltage for IO lines	0		$0.2V_{DD}$	V	
V_{IH}	Input high voltage for IO lines	$0.7 V_{DD}$		V_{DD}	V	
I_{OL}	IO lines sink current PA5 only	8	11	14	mA	$V_{DD}=5.0V, V_{OL}=0.5V$
		3	4	5.5		
I_{OH}	IO lines drive current	-6	-8	-10	mA	$V_{DD}=5.0V, V_{OH}=4.5V$
V_{IN}	Input voltage	-0.3		$V_{DD}+0.3$	V	
$I_{INJ(PIN)}$	Injected current on pin			1	mA	$V_{DD}+0.3 \geq V_{IN} \geq -0.3$
R_{PH}	Pull-high Resistance		62		K Ω	$V_{DD}=5.0V$ $V_{DD}=3.3V$ $V_{DD}=2.2V$
			100			
			210			
V_{LVR}	Low Voltage Detect Voltage * (Brown-out voltage)	3.86	4.15	4.44	V	
		3.35	3.60	3.85		
		2.84	3.05	3.26		
		2.61	2.80	3.00		
		2.37	2.55	2.73		
		2.04	2.20	2.35		
		1.86	2.00	2.14		
		1.67	1.80	1.93		
V_{BG}	Band-gap Reference Voltage (before calibration)	1.11	1.20	1.29	V	$V_{DD}=5V, 25^{\circ}C$
	Band-gap Reference Voltage * (after calibration)	1.140* 1.145*	1.200* 1.200*	1.260* 1.255*		$V_{DD}=2.2V \sim 5.5V$ $-40^{\circ}C < Ta < 85^{\circ}C$ * $-20^{\circ}C < Ta < 70^{\circ}C$ *

Symbol	Description	Min	Typ	Max	Unit	Conditions (Ta=25°C)
f _{IHRC}	Frequency of IHRC after calibration *	15.76*	16*	16.24*	MHz	25°C, V _{DD} =2.2V~5.5V
		15.04*	16*	16.96*		V _{DD} =2.2V~5.5V, -40°C <Ta<85°C*
		15.20*	16*	16.80*		-20°C <Ta<70°C*
f _{ILRC}	Frequency of ILRC *	31.3*	37*	41.9*	kHz	V _{DD} =5.0V, Ta=25°C
		24.0*	37*	50.0*		V _{DD} =5.0V, -40°C <Ta<85°C*
		25.9*	37*	48.1*		V _{DD} =5.0V, -20°C <Ta<70°C*
		18.3*	21*	24.5*		V _{DD} =3.3V, Ta=25°C
		14.0*	21*	29.0*		V _{DD} =3.3V, -40°C <Ta<85°C*
14.7*	21*	27.3*	V _{DD} =3.3V, -20°C <Ta<70°C*			
t _{INT}	Interrupt pulse width	30			ns	V _{DD} = 5.0V
V _{ADC}	Supply voltage for workable ADC	2.5		5.0	V	
V _{AD}	AD Input Voltage	0		V _{DD}	V	
ADrs	ADC resolution			12	bit	
ADcs	ADC current consumption		0.9 0.8		mA	@5V @3V
ADclk	ADC clock period		2		us	2.5V ~ 5.5V
t _{ADCONV}	ADC conversion time (T _{ADCLK} is the period of the selected AD conversion clock)		13 14 15 16 17		T _{ADCLK}	8-bit resolution 9-bit resolution 10-bit resolution 11-bit resolution 12-bit resolution
AD DNL	ADC Differential NonLinearity		±2*		LSB	
AD INL	ADC Integral NonLinearity		±4*		LSB	
ADos	ADC offset*		3		mV	@V _{DD} =3V
V _{REFH}	ADC reference high voltage					@V _{DD} =5V
	4V	3.90	4	4.10		
	3V	2.93	3	3.07		
V _{DR}	RAM data retention voltage*	1.5			V	in stop mode.
t _{WDT}	Watchdog timeout period		2048		T _{ILRC}	misc[1:0]=00 (default)
			4096			misc[1:0]=01
			16384			misc[1:0]=10
			256			misc[1:0]=11

Symbol	Description	Min	Typ	Max	Unit	Conditions (Ta=25°C)
t _{WUP}	System wake-up period					
	Fast wake-up by IO toggle from STOPEXE suspend		128		T _{SYS}	Where T _{SYS} is the time period of system clock
	Fast wake-up by IO toggle from STOPSYS suspend, IHRC is the system clock		128 T _{SYS} + T _{SIHRC}			Where T _{SIHRC} is the stable time of IHRC from power-on. T _{SIHRC} = 5us@5V
	Fast wake-up by IO toggle from STOPSYS suspend, ILRC is the system clock		128 T _{SYS} + T _{SILRC}			Where T _{SILRC} is the stable time of ILRC from power-on. T _{SILRC} = 43ms@5V
	Normal wake-up from STOPEXE or STOPSYS suspend		1024		T _{ILRC}	Where T _{ILRC} is the clock period of ILRC
t _{SBP}	System boot-up period from power-on		1024		T _{ILRC}	Where T _{ILRC} is the clock period of ILRC
t _{RST}	External reset pulse width	120			us	@V _{DD} =5V

*These parameters are for design reference, not tested for each chip.

** Under_20ms_V_{DD}_Ok is a checking condition for the V_{DD} rising from 0V to the stated voltage within 20ms.

4.2. Absolute Maximum Ratings

- Supply Voltage 2.2V ~ 5.5V
- Input Voltage -0.3V ~ V_{DD} + 0.3V
- Operating Temperature PMC131 series: -40°C ~ 85°C
PMS131, PMS130 series: -20°C ~ 70°C
- Junction Temperature 150°C
- Storage Temperature -50°C ~ 125°C

4.3. Typical ILRC frequency vs. VDD and temperature

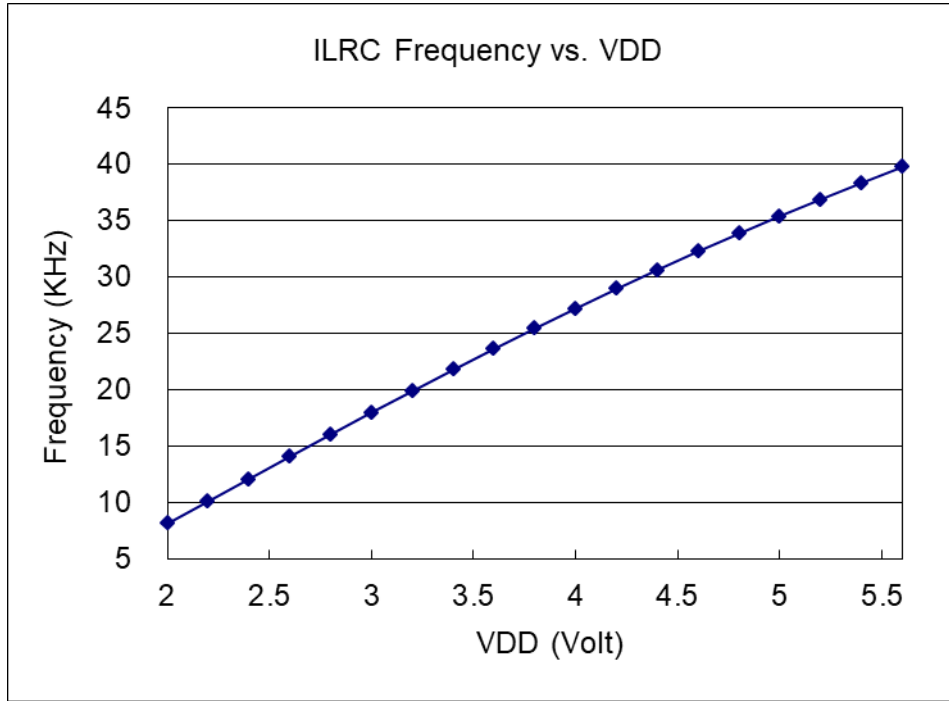

4.4. Typical IHRC frequency deviation vs. VDD (calibrated to 16MHz)

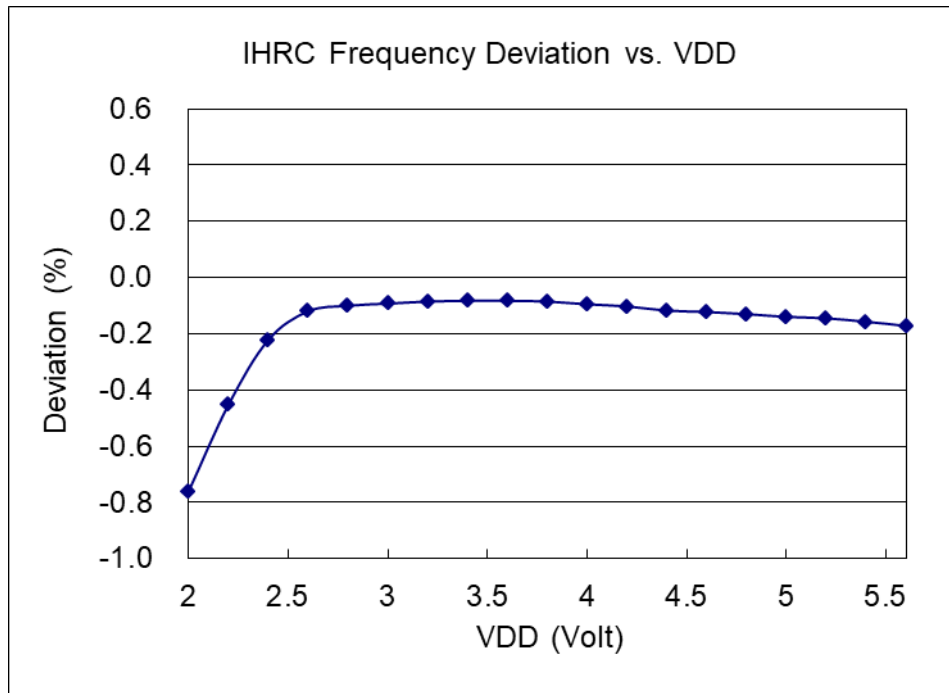

4.5. Typical ILRC Frequency vs. Temperature

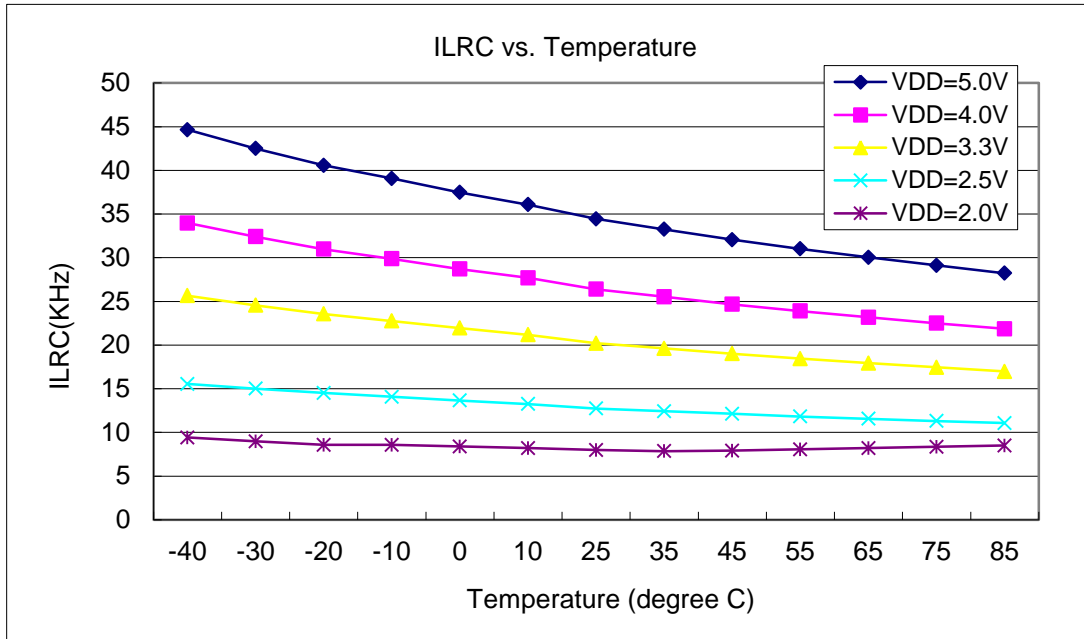

4.6. Typical IHRC Frequency vs. Temperature (calibrated to 16MHz)

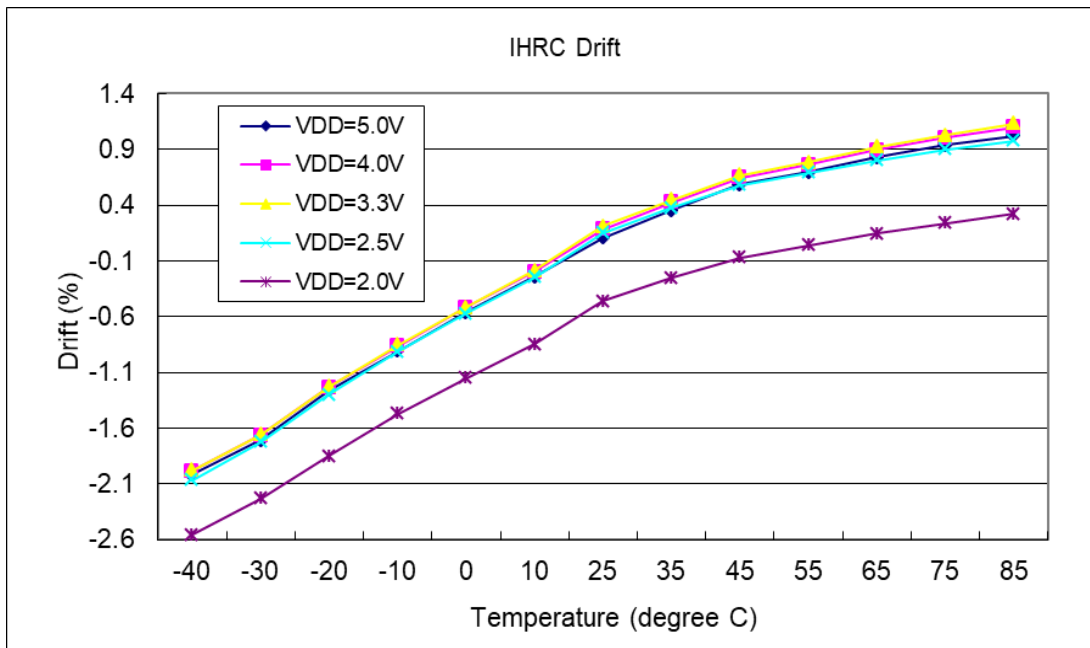

4.7. Typical operating current vs. VDD @ system clock = ILRC/n

Conditions:

ON: ILRC;

OFF: Band-gap, LVR, IHRC, EOSC, T16, TM2, TM3, ADC modules;

IO: PA0:0.5Hz output toggle and no loading, others: input and no floating

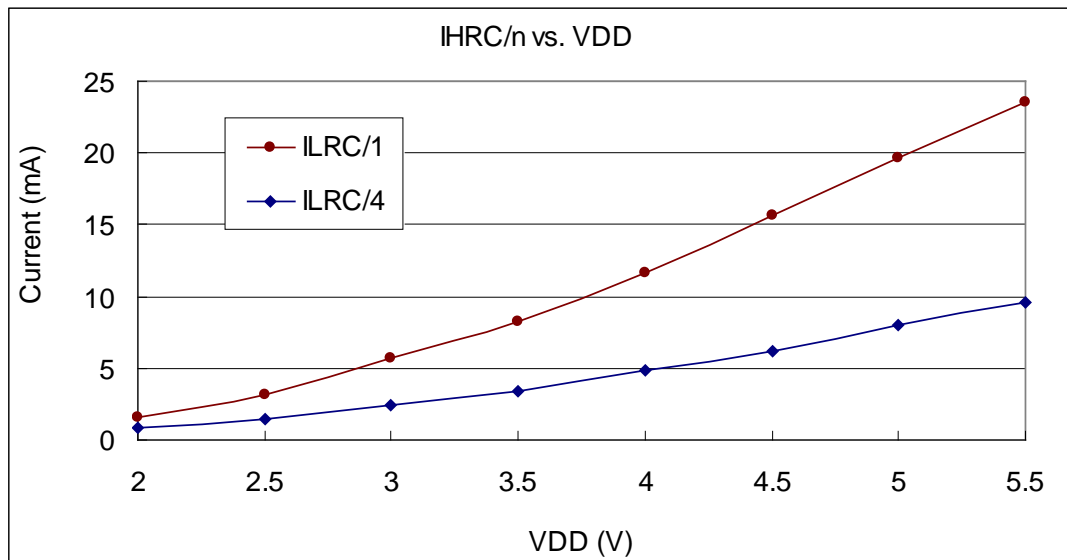

4.8. Typical operating current vs. VDD @ system clock = IHRC/n

Conditions:

ON: Band-gap, LVR, IHRC;

OFF: ILRC, EOSC, LVR, T16, TM2, TM3, ADC modules;

IO: PA0:0.5Hz output toggle and no loading, others: input and no floating

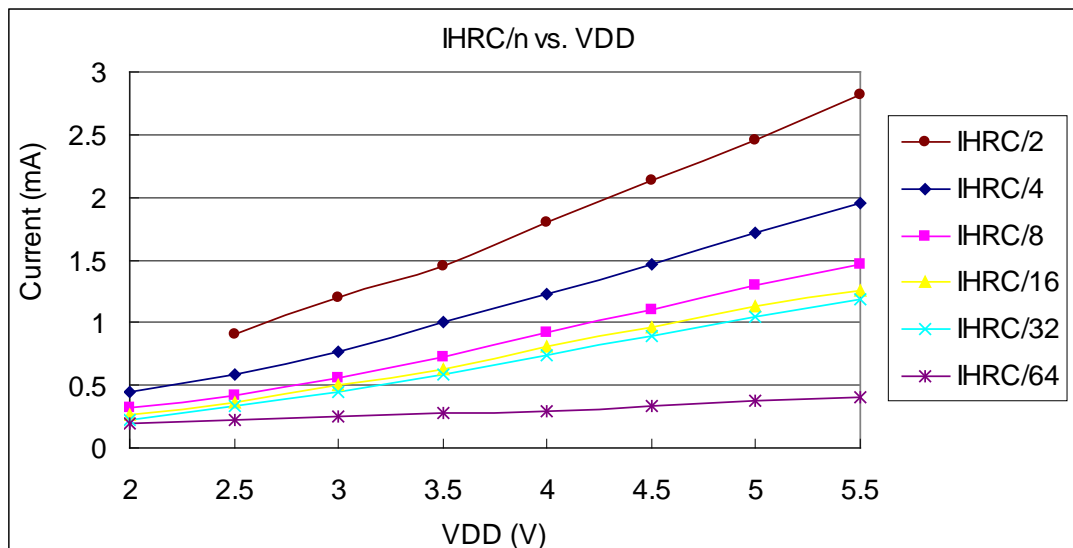

4.9. Typical operating current vs. VDD @ system clock = 4MHz EOSC / n

Conditions:

ON: EOSC, MISC.6 = 1;

OFF: Band-gap, LVR, IHRC, ILRC, T16, TM2, TM3, ADC modules;

IO: PA0:0.5Hz output toggle and no loading, others: input and no floating

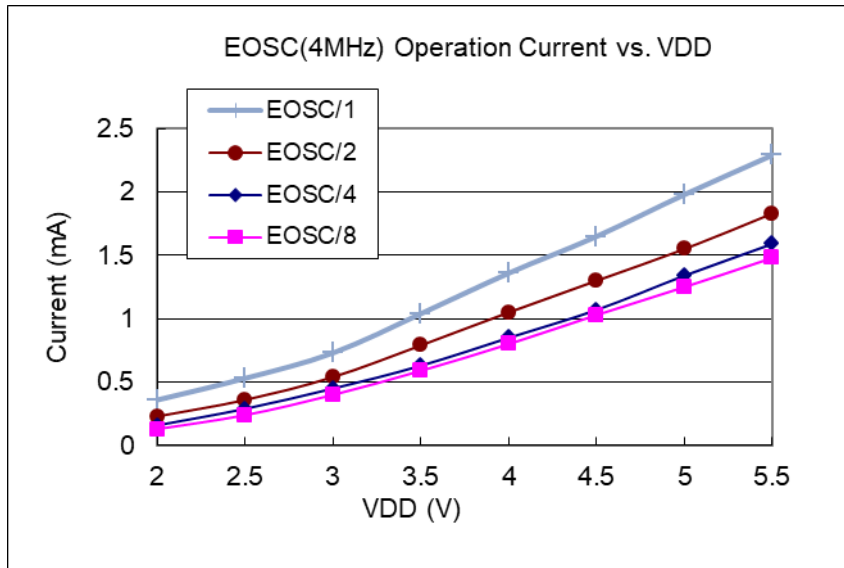

4.10. Typical operating current vs. VDD @ system clock = 32kHz EOSC / n

Conditions:

ON: EOSC, MISC.6 = 1;

OFF: Band-gap, LVR, IHRC, ILRC, T16, TM2, TM3, ADC modules;

IO: PA0:0.5Hz output toggle and no loading, others: input and no floating

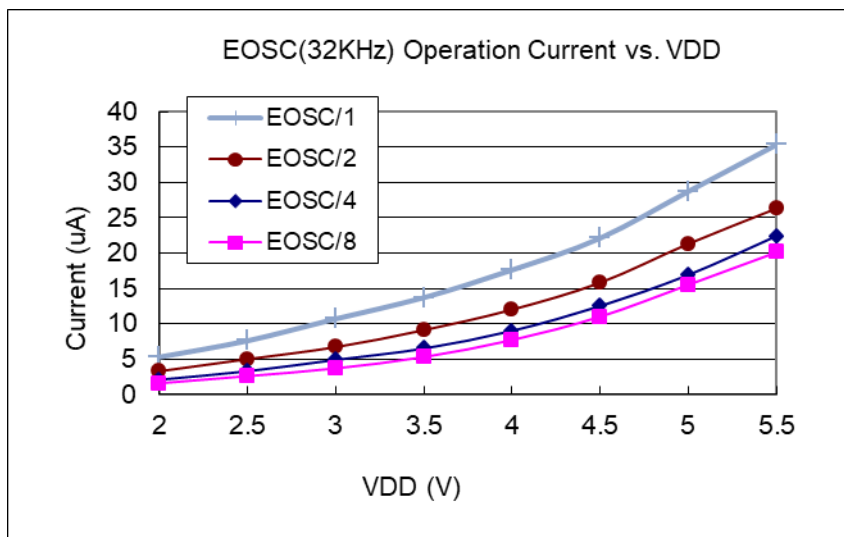

4.11. Typical operating current vs. VDD @ system clock = 1MHz EOSC / n

Conditions:

ON: EOSC, MISC.6 = 1;

OFF: Band-gap, LVR, IHRC, ILRC, T16, TM2, TM3, ADC modules;

IO: PA0:0.5Hz output toggle and no loading, others: input and no floating

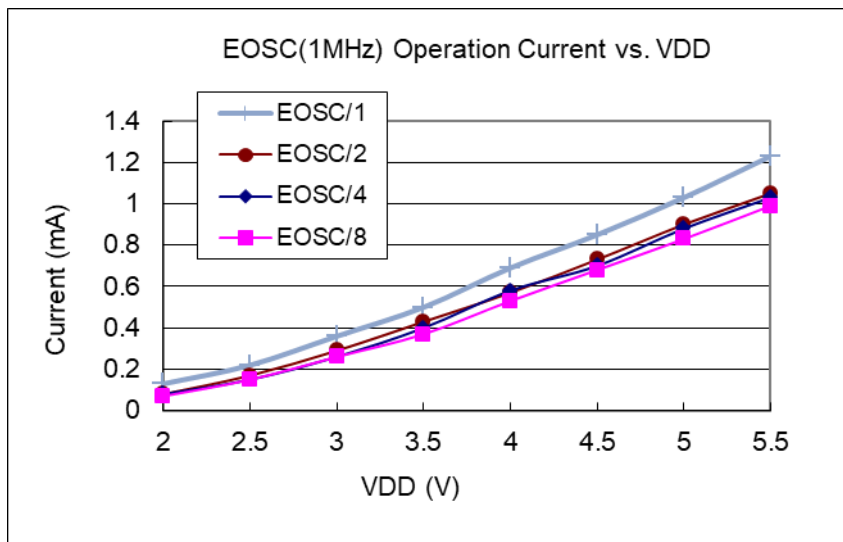

4.12. Typical IO driving current (I_{OH}) and sink current (I_{OL})

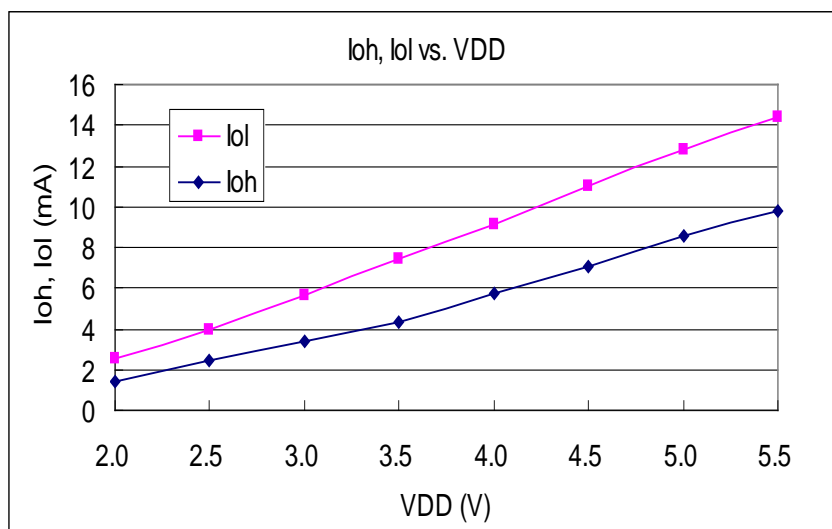

4.13. Typical IO input high/low threshold voltage (V_{IH}/V_{IL})

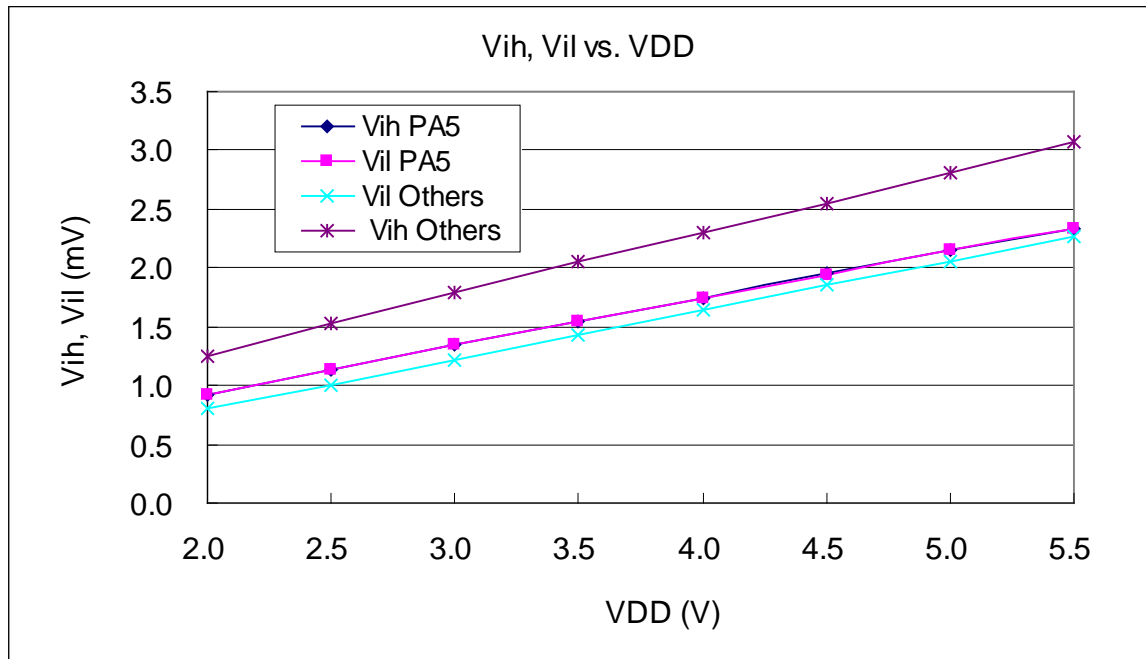

4.14. Typical resistance of IO pull high device

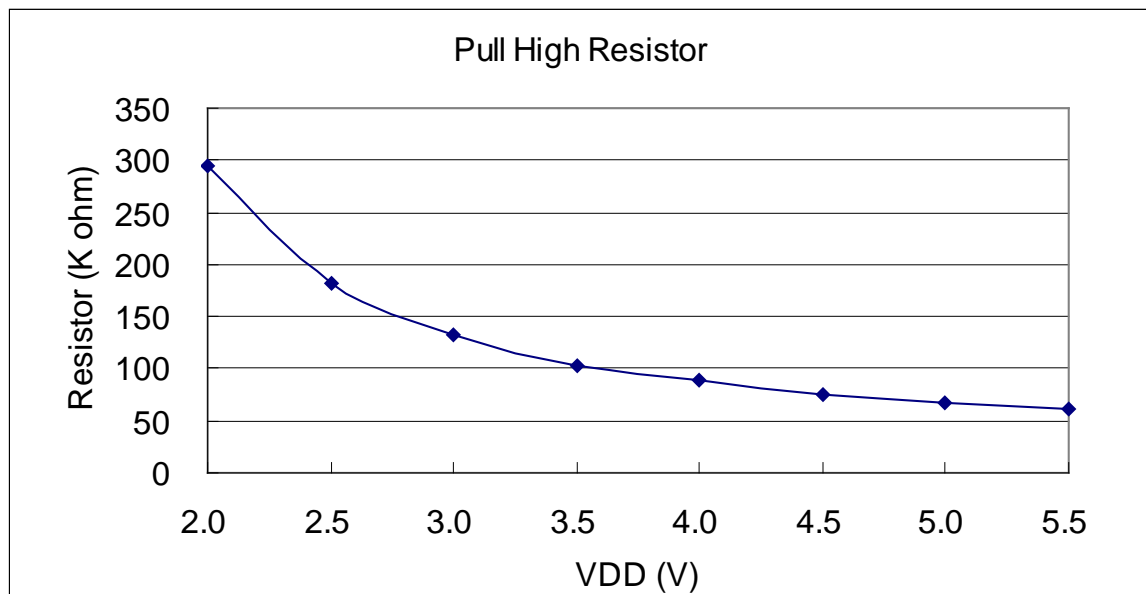

4.15. Typical power down current (I_{PD}) and power save current (I_{PS})

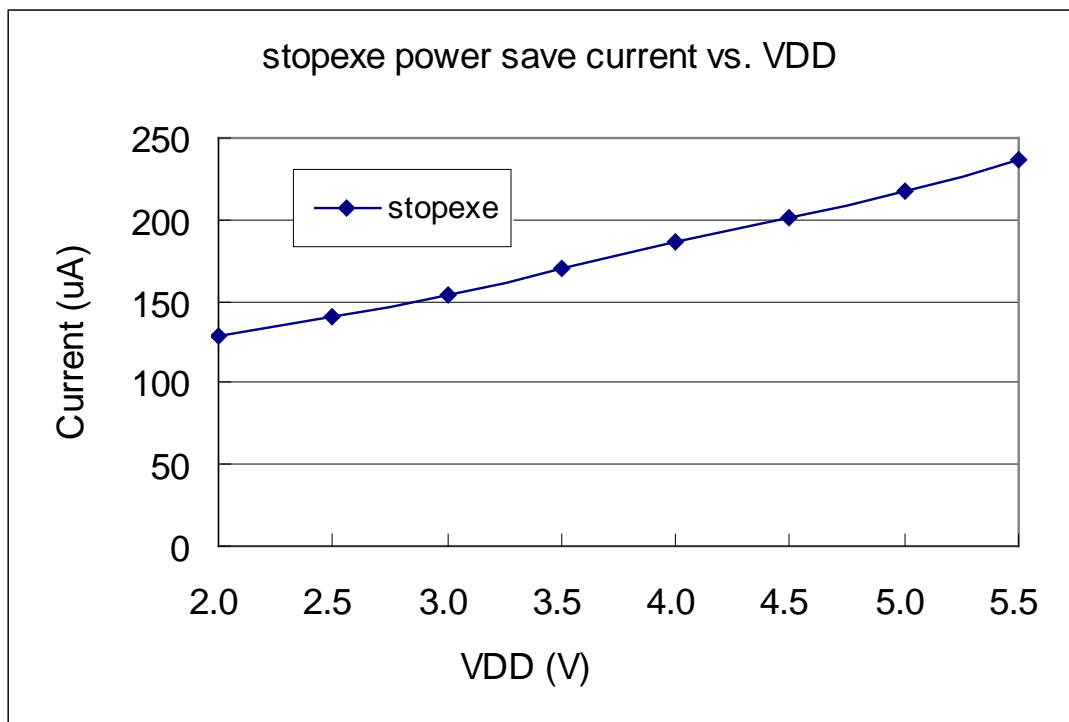
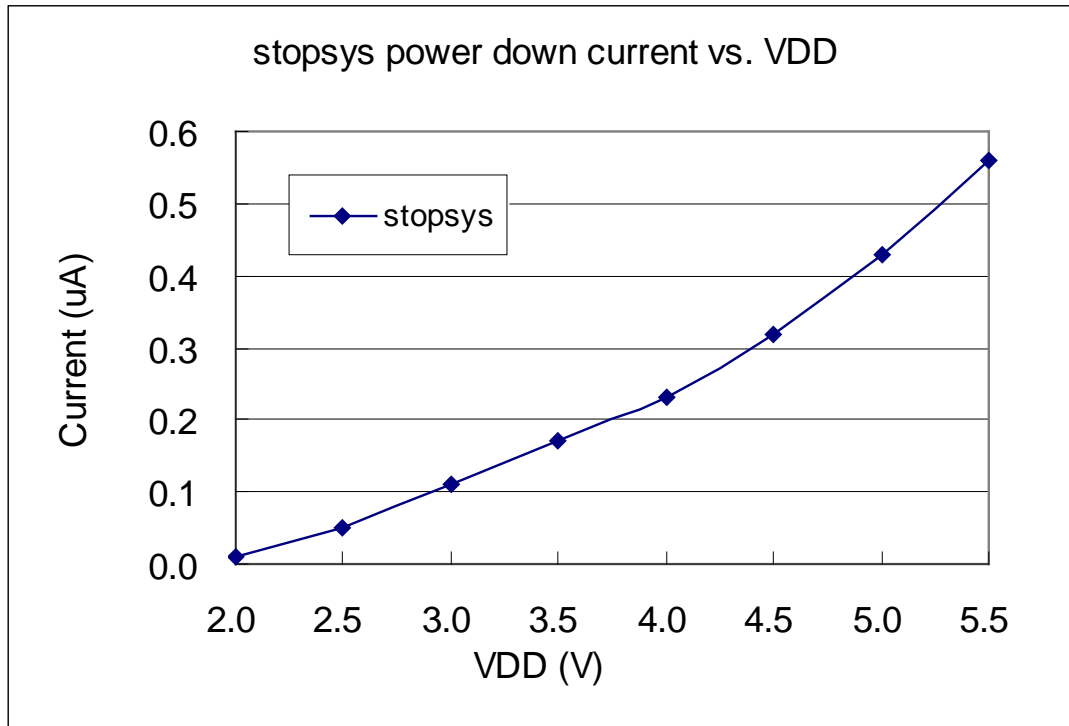

5. Functional Description

5.1. Program Memory -- OTP

The OTP (One Time Programmable) program memory is used to store the program instructions to be executed. The OTP program memory may contains the data, tables and interrupt entry. After reset, the initial address is 0x00. The interrupt entry is 0x10 if used, the last eight addresses are reserved for system using, like checksum, serial number, etc. The OTP program memory for PMC131/PMS131/PMS130 is a 1.5Kx14 bit that is partitioned as Table 1. The OTP memory from address '0x5F8 to 0x5FF is for system using, address space from 0x001 to 0x00F and from 0x011 to 0x5F7 are user program spaces.

Address	Function
0x000	Reset – goto instruction
0x001	User program
0x002	User program
•	•
0x00F	User program
0x010	Interrupt entry address
0x011	User program
•	•
0x5F7	User program
0x5F8	System Using
•	•
0x5FF	System Using

Table 1: Program Memory Organization

5.2. Boot Procedure

POR (Power-On-Reset) is used to reset PMC131/PMS131/PMS130 when power up, however, the supply voltage may be not stable. To ensure the stability of supply voltage after power up, it will wait 1024 ILRC clock cycles before first instruction being executed, which is t_{SBP} and shown in the Fig. 1. After boot up procedure, the default system clock is ILRC; user should ensure that the power should be stable after boot up time.

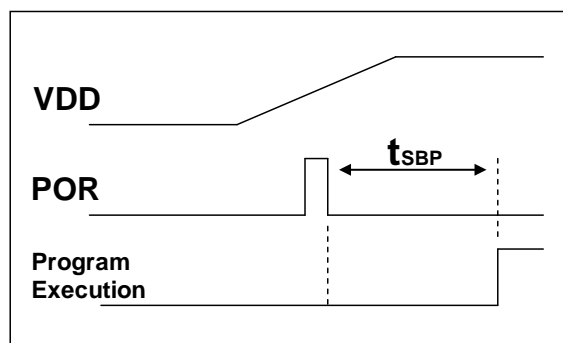

Boot up from Power-On Reset

Fig.1: Power-Up Sequence

5.2.1. Timing charts for reset conditions

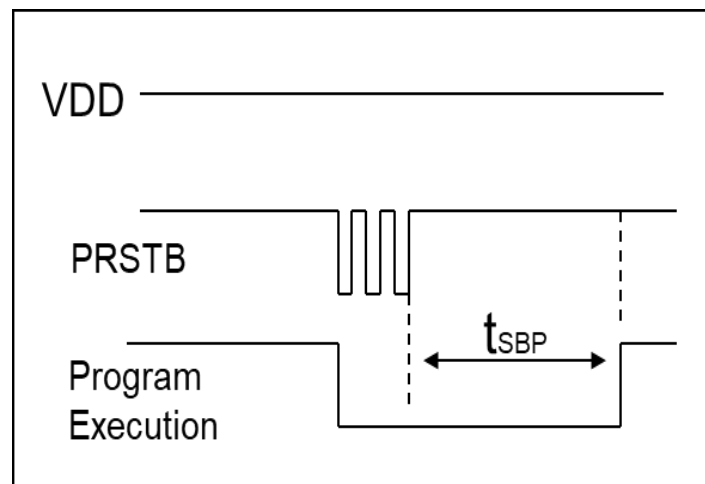
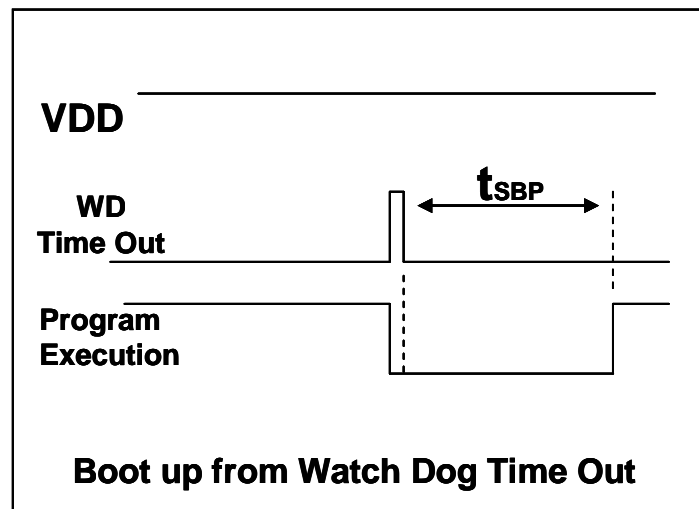
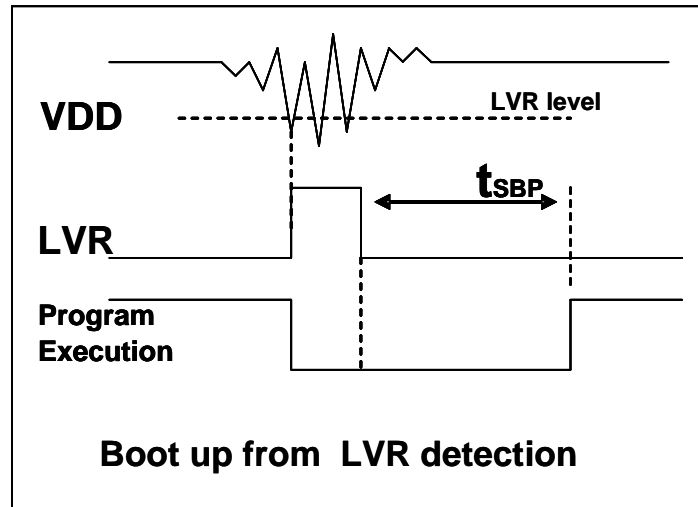

5.3. Data Memory - SRAM

The access of data memory can be byte or bit operation. Besides data storage, the SRAM data memory is also served as data pointer of indirect access method and the stack memory.

For indirect memory access mechanism, the data memory is used as the data pointer to address the data byte. All the data memory could be the data pointer; it's quite flexible and useful to do the indirect memory access. Since the data width is 8-bit, all the 88 bytes data memory of PMC131/PMS131/PMS130 can be accessed by indirect access mechanism.

5.4. Oscillator and clock

There are three oscillator circuits provided by PMC131/PMS131/PMS130: external crystal oscillator (EOSC), internal high RC oscillator (IHRC) and internal low RC oscillator (ILRC), and these three oscillators are enabled or disabled by registers `eoscr.7`, `clkmd.4` and `clkmd.2` independently. User can choose one of these three oscillators as system clock source and use ***clkmd*** register to target the desired frequency as system clock to meet different applications.

Oscillator Module	Enable/Disable
EOSC	<code>eoscr.7</code>
IHRC	<code>clkmd.4</code>
ILRC	<code>clkmd.2</code>

Table 2: Three oscillation circuits

5.4.1. Internal High RC oscillator and Internal Low RC oscillator

After boot-up, the IHRC and ILRC oscillators are enabled. The frequency of IHRC can be calibrated to eliminate process variation by ***ihrcr*** register; normally it is calibrated to 16MHz. Please refer to the measurement chart for IHRC frequency verse V_{DD} and IHRC frequency verse temperature. The frequency will vary by process, supply voltage and temperature, please refer to DC specification and do not use for accurate timing application.

5.4.2. Chip calibration

The IHRC frequency and band-gap reference voltage may be different chip by chip due to manufacturing variation, PMC131/PMS131/PMS130 provide both the IHRC frequency calibration and band-gap calibration to eliminate this variation, and this function can be selected when compiling user's program and the command will be inserted into user's program automatically. The calibration command is shown as below:

```
.ADJUST_IC SYSCLK=IHRC/(p1), IHRC=(p2)MHz, VDD=(p3)V, Band-gap=(p4);
```

Where, **p1**=2, 4, 8, 16, 32; In order to provide different system clock.

p2=14 ~ 18; In order to calibrate the chip to different frequency, 16MHz is the usually one.

p3=2.5 ~ 5.5; In order to calibrate the chip under different supply voltage.

p4= On or Off; Band-gap calibration is On or Off.

5.4.3. IHRC Frequency Calibration and System Clock

During compiling the user program, the options for IHRC calibration and system clock are shown as Table 3:

SYSCLK	CLKMD	IHRCR	Description
○ Set IHRC / 2	= 34h (IHRC / 2)	Calibrated	IHRC calibrated to 16MHz, CLK=8MHz (IHRC/2)
○ Set IHRC / 4	= 14h (IHRC / 4)	Calibrated	IHRC calibrated to 16MHz, CLK=4MHz (IHRC/4)
○ Set IHRC / 8	= 3Ch (IHRC / 8)	Calibrated	IHRC calibrated to 16MHz, CLK=2MHz (IHRC/8)
○ Set IHRC / 16	= 1Ch (IHRC / 16)	Calibrated	IHRC calibrated to 16MHz, CLK=1MHz (IHRC/16)
○ Set IHRC / 32	= 7Ch (IHRC / 32)	Calibrated	IHRC calibrated to 16MHz, CLK=0.5MHz (IHRC/32)
○ Set ILRC	= E4h (ILRC / 1)	Calibrated	IHRC calibrated to 16MHz, CLK=ILRC
○ Disable	No change	No Change	IHRC not calibrated, CLK not changed, Band-gap OFF

Table 3: Options for IHRC Frequency Calibration

Usually, .ADJUST_IC will be the first command after boot up, in order to set the target operating frequency whenever starting the system. The program code for IHRC frequency calibration is executed only one time that occurs in writing the codes into OTP memory; after then, it will not be executed again. If the different option for IHRC calibration is chosen, the system status is also different after boot. The following shows the status of PMC131/PMS131/PMS130 for different option:

(1) .ADJUST_IC SYSCLK=IHRC/2, IHRC=16MHz, V_{DD}=5V, Band-gap=On

After boot up, CLKMD = 0x34:

- ◆ IHRC frequency is calibrated to 16MHz@V_{DD}=5V and IHRC module is enabled
- ◆ System CLK = IHRC/2 = 8MHz
- ◆ Watchdog timer is disabled, ILRC is enabled, PA5 is in input mode, BG=1.2V

(2) .ADJUST_IC SYSCLK=IHRC/4, IHRC=16MHz, V_{DD}=3.3V, Band-gap=On

After boot up, CLKMD = 0x14:

- ◆ IHRC frequency is calibrated to 16MHz@V_{DD}=3.3V and IHRC module is enabled
- ◆ System CLK = IHRC/4 = 4MHz
- ◆ Watchdog timer is disabled, ILRC is enabled, PA5 is in input mode, BG=1.2V

(3) .ADJUST_IC SYSCLK=IHRC/8, IHRC=16MHz, V_{DD}=2.5V, Band-gap=On

After boot up, CLKMD = 0x3C:

- ◆ IHRC frequency is calibrated to 16MHz@V_{DD}=2.5V and IHRC module is enabled
- ◆ System CLK = IHRC/8 = 2MHz
- ◆ Watchdog timer is disabled, ILRC is enabled, PA5 is in input mode, BG=1.2V

(4) .ADJUST_IC SYSCLK=IHRC/16, IHRC=16MHz, V_{DD}=2.5V, Band-gap=On

After boot up, CLKMD = 0x1C:

- ◆ IHRC frequency is calibrated to 16MHz@V_{DD}=2.5V and IHRC module is enabled
- ◆ System CLK = IHRC/16 = 1MHz
- ◆ Watchdog timer is disabled, ILRC is enabled, PA5 is in input mode, BG=1.2V

(5) .ADJUST_IC SYSCLK=IHRC/32, IHRC=16MHz, V_{DD}=5V, Band-gap=Off

After boot up, CLKMD = 0x7C:

- ◆ IHRC frequency is calibrated to 16MHz@V_{DD}=5V and IHRC module is enabled
- ◆ System CLK = IHRC/32 = 500kHz
- ◆ Watchdog timer is disabled, ILRC is enabled, PA5 is in input mode

(6) .ADJUST_IC SYSCLK=ILRC, IHRC=16MHz, V_{DD}=5V, Band-gap=Off

After boot up, CLKMD = 0XE4:

- ◆ IHRC frequency is calibrated to 16MHz@VDD=5V and IHRC module is disabled
- ◆ System CLK = ILRC
- ◆ Watchdog timer is disabled, ILRC is enabled, PA5 is input mode

(7) .ADJUST_IC DISABLE

After boot up, CLKMD is not changed (Do nothing):

- ◆ IHRC is not calibrated and IHRC module is disabled, Band-gap is not calibrated
- ◆ System CLK = ILRC or IHRC/64
- ◆ Watchdog timer is enabled, ILRC is enabled, PA5 is in input mode,

5.4.4. External Crystal Oscillator

If crystal oscillator is used, a crystal or resonator is required between X1 and X2. Fig. 2 shows the hardware connection under this application; the range of operating frequency of crystal oscillator can be from 32 kHz to 4MHz, depending on the crystal placed on; higher frequency oscillator than 4MHz is NOT supported.

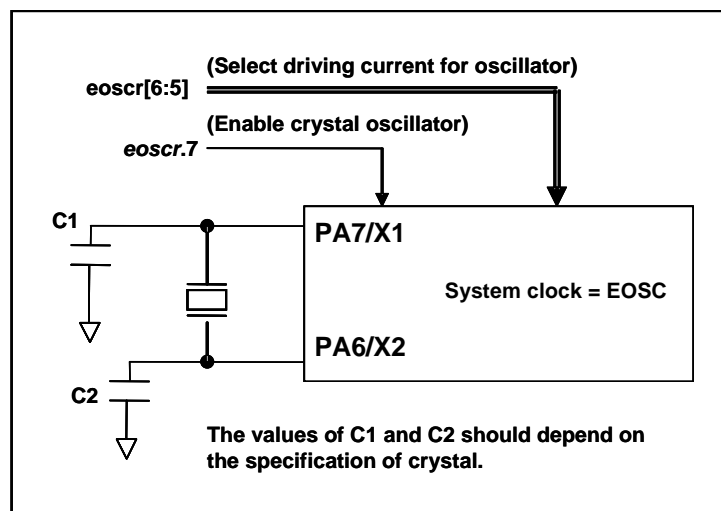

Fig.2: Connection of crystal oscillator

Besides crystal, external capacitor and options of PMC131/PMS131/PMS130 should be fine tuned in eoscr (0x0b) register to have good sinusoidal waveform. The eoscr.7 is used to enable crystal oscillator module, eoscr.6 and eoscr.5 are used to set the different driving current to meet the requirement of different frequency of crystal oscillator:

- ◆ eoscr.[6:5]=01 : Low driving capability, for lower frequency, ex: 32kHz crystal oscillator
- ◆ eoscr.[6:5]=10 : Middle driving capability, for middle frequency, ex: 1MHz crystal oscillator
- ◆ eoscr.[6:5]=11 : High driving capability, for higher frequency, ex: 4MHz crystal oscillator

Table 4 shows the recommended values of C1 and C2 for different crystal oscillator; the measured start-up time under its corresponding conditions is also shown. Since the crystal or resonator had its own characteristic, the capacitors and start-up time may be slightly different for different type of crystal or resonator, please refer to its specification for proper values of C1 and C2.

Frequency	C1	C2	Measured Start-up time	Conditions
4MHz	4.7pF	4.7pF	6ms	(<i>eoscr</i> [6:5]=11, <i>misc</i> .6=0)
1MHz	10pF	10pF	11ms	(<i>eoscr</i> [6:5]=10, <i>misc</i> .6=0)
32kHz	22pF	22pF	450ms	(<i>eoscr</i> [6:5]=01, <i>misc</i> .6=0)

Table 4: Recommend values of C1 and C2 for crystal and resonator oscillators

When using the crystal oscillator, user must pay attention to the stable time of oscillator after enabling it, the stable time of oscillator will depend on frequency ` crystal type ` external capacitor and supply voltage. Before switching the system to the crystal oscillator, user must make sure the oscillator is stable; the reference program is shown as below:

```

void  FPPA0 (void)
{
    . ADJUST_IC  SYSCLK=IHRC/16, IHRC=16MHz, VDD=5V, Band-gap=On
    // If Band-gap is not calibrated, it can use ". ADJUST_IC  DISABLE" ...
    $    EOSCR Enable, 4MHz;           // EOSCR = 0b110_00000;

    $    T16M EOSC, /1, BIT13;         // T16 receive 2^14=16384 clocks of crystal EOSC,
                                           // Intrq.T16 =>1, crystal EOSC Is stable

    WORD count = 0;
    stt16 count;
    Intrq.T16 = 0;
    do
    {
        nop;
    } while(!Intrq.T16);           // count from 0x0000 to 0x2000, then set INTRQ.T16
    clkmd= 0xB4;                 // switch system clock to EOSC;
    clkmd.4=0;                   // close IHRC
    ...
}

```

Please notice that the crystal oscillator should be fully turned off before entering the power-down mode, in order to avoid unexpected wakeup event. If the 32kHz crystal oscillator is used and extremely low operating current is required, *misc*.6 can be set to "1" to reduce current after crystal oscillator is running normally.

5.4.5. System Clock and LVR level

The clock source of system clock comes from EOSC, IHRC and ILRC, the hardware diagram of system clock in the PMC131/PMS131/PMS130 is shown as Fig. 3.

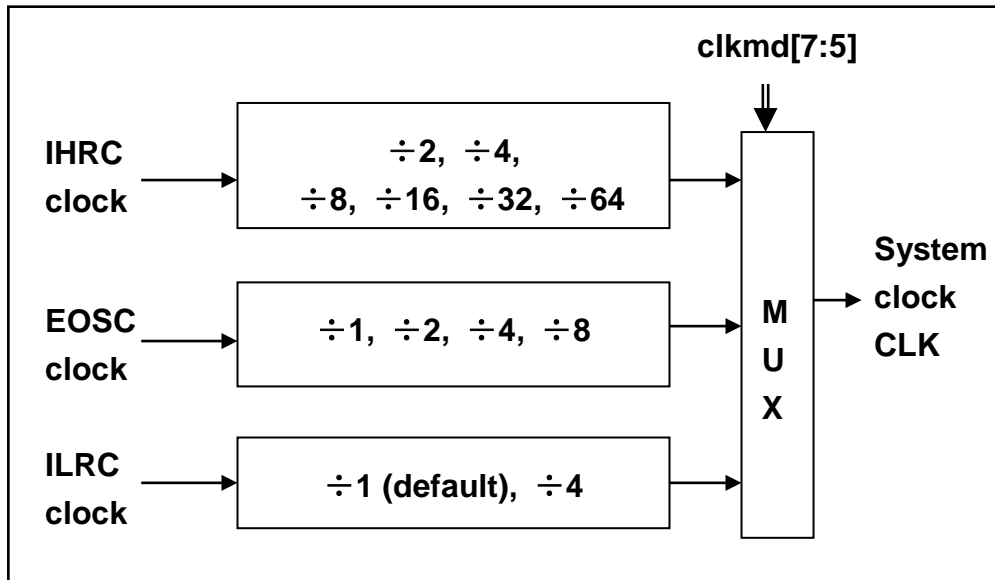

Fig.3: Options of System Clock

User can choose different operating system clock depends on its requirement; the selected operating system clock should be combined with supply voltage and LVR level to make system stable. The LVR level will be selected during compilation, and the lowest LVR levels can be chosen for different operating frequencies. Please refer to Section 4.1.

5.4.6. System Clock Switching

After IHRC calibration, user may want to switch system clock to a new frequency or may switch system clock at any time to optimize the system performance and power consumption. Basically, the system clock of PMC131/PMS131/PMS130 can be switched among IHRC, ILRC and EOSC by setting the **clkmd** register at any time; system clock will be the new one after writing to **clkmd** register immediately. Please notice that the original clock module can NOT be turned off at the same time as writing command to **clkmd** register. The examples are shown as below and more information about clock switching, please refer to the “Help” -> “Application Note” -> “IC Introduction” -> “Register Introduction” -> CLKMD”.

Case 1: Switching system clock from ILRC to IHRC/2

```

... // system clock is ILRC
CLKMD = 0x34; // switch to IHRC/2, ILRC CAN NOT be disabled here
CLKMD.2 = 0; // ILRC CAN be disabled at this time
...

```

Case 2: Switching system clock from ILRC to EOSC

```

... // system clock is ILRC
CLKMD = 0xA6; // switch to IHRC, ILRC CAN NOT be disabled here
CLKMD.2 = 0; // ILRC CAN be disabled at this time
...

```

Case 3: Switching system clock from IHRC/2 to ILRC

```

... // system clock is IHRC/2
CLKMD = 0xF4; // switch to ILRC, IHRC CAN NOT be disabled here
CLKMD.4 = 0; // IHRC CAN be disabled at this time
...

```

Case 4: Switching system clock from IHRC/2 to EOSC

```

... // system clock is IHRC/2
CLKMD = 0xB0; // switch to EOSC, IHRC CAN NOT be disabled here
CLKMD.4 = 0; // IHRC CAN be disabled at this time
...

```

Case 5: Switching system clock from IHRC/2 to IHRC/4

```

... // system clock is IHRC/2, ILRC is enabled here
CLKMD = 0X14; // switch to IHRC/4
...

```

Case 6: System may hang if it is to switch clock and turn off original oscillator at the same time

```

... // system clock is ILRC
CLKMD = 0x30; // CAN NOT switch clock from ILRC to IHRC/2 and  

// turn off ILRC oscillator at the same time

```

5.5. 16-bit Timer (Timer16)

A 16-bit hardware timer (Timer16) is implemented in the PMC131/PMS131/PMS130, the clock sources of Timer16 may come from system clock (CLK), clock of external crystal oscillator (EOSC), internal high RC oscillator (IHRC), internal low RC oscillator (ILRC) and PA0, PA4 a multiplex is used to select clock output for the clock source. Before sending clock to the counter16, a pre-scaling logic with divided-by-1, 4, 16, and 64 is used for wide range counting. The 16-bit counter performs up-counting operation only, the counter initial values can be stored from memory by *stt16* instruction and the counting values can be loaded to memory by *ldt16* instruction. A selector is used to select the interrupt condition of Timer16, whenever overflow occurs, the Timer16 interrupt can be triggered. The hardware diagram of Timer16 is shown as Fig. 4. The interrupt source of Timer16 comes from one of bit 8 to 15 of 16-bit counter, and the interrupt type can be rising edge trigger or falling edge trigger which is specified in the bit 4 of *integs* register (IO address 0x0C).

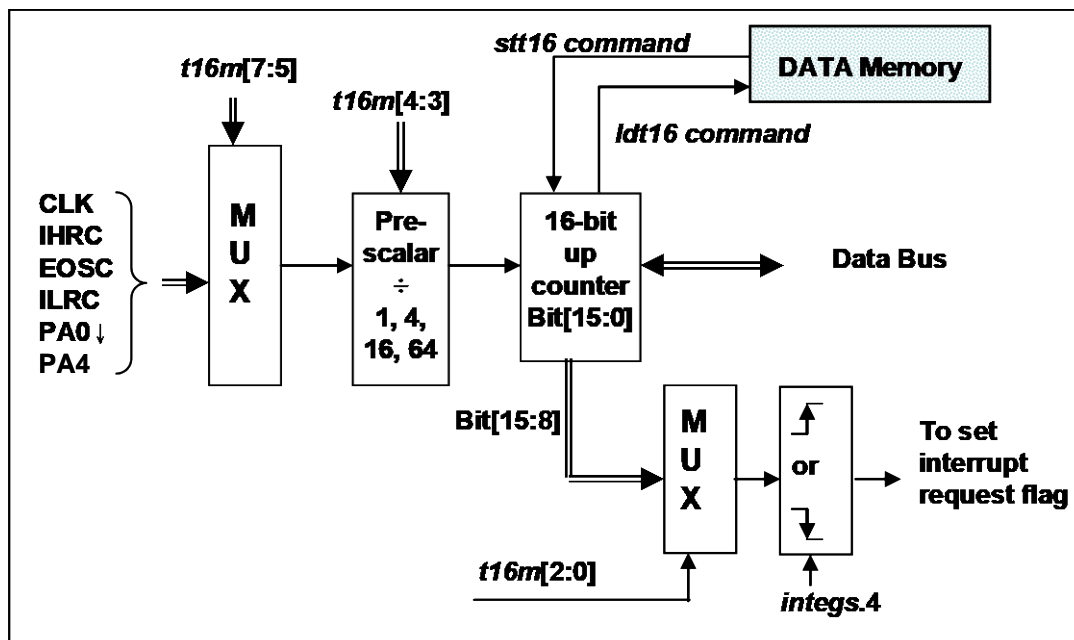

Fig.4: Hardware diagram of Timer16

When using the Timer16, the syntax for Timer16 has been defined in the .INC file. There are three parameters to define the Timer16; 1st parameter is used to define the clock source of Timer16, 2nd parameter is used to define the pre-scaler and the last one is to define the interrupt source. The detail description is shown as below:

```

T16M IO_RW    0x06
$ 7~5:  STOP, SYSCLK, PA4_F, X, IHRC, EOSC, ILRC, PA0_F // 1st par.
$ 4~3:  /1, /4, /16, /64 // 2nd par.
$ 2~0:  BIT8, BIT9, BIT10, BIT11, BIT12, BIT13, BIT14, BIT15 // 3rd par.

```

User can define the parameters of T16M based on system requirement, some examples are shown below and more examples please refer to “Help → Application Note → IC Introduction → Register Introduction → T16M” in IDE utility.

\$ T16M SYSCLK, /64, BIT15;

*// choose (SYSCLK/64) as clock source, every 2¹⁶ clock to set INTRQ.2=1
 // if using System Clock = IHRC / 2 = 8 MHz
 // SYSCLK/64 = 8 MHz/64 = 125kHz, about every 512 mS to generate INTRQ.2=1*

\$ T16M EOSC, /1, BIT13;

*// choose (EOSC/1) as clock source, every 2¹⁴ clocks to generate INTRQ.2=1
 // if EOSC=32768 Hz, 32768 Hz/(2¹⁴) = 2Hz, every 0.5S to generate INTRQ.2=1*

\$ T16M PA0_F, /1, BIT8;

*// choose PA0 as clock source, every 2⁹ to generate INTRQ.2=1
 // receiving every 512 times PA0 to generate INTRQ.2=1*

\$ T16M STOP;

// stop Timer16 counting

If Timer16 is operated at free running, the frequency of interrupt can be described as below:

$$F_{\text{INTRQ_T16M}} = F_{\text{clock source}} \div P \div 2^{n+1}$$

Where, F is the frequency of selected clock source to Timer16;

P is the selection of t16m [4:3]; (1, 4, 16, 64)

N is the nth bit selected to request interrupt service, for example: n=10 if bit 10 is selected.

5.6. 8-bit Timer (Timer2/Timer3) with PWM generation

Two 8-bit hardware timers (Timer2 and Timer3) with PWM generation are implemented in the PMC131/PMS131/PMS130. The following descriptions thereafter are for Timer2 only. It is because Timer3 have same structure with Timer2. Please refer to Fig. 5 shown the hardware diagram of Timer2, the clock sources of Timer2 may come from system clock, internal high RC oscillator (IHRC), internal low RC oscillator (ILRC), PA0, PB0 and PA4, bit [7:4] of register `tm2c` are used to select the clock of Timer2. Please notice that external crystal oscillator is NOT to be the clock of Timer2 because of possible clock glitch. If IHRC is selected for Timer2 clock source, the clock sent to Timer2 will keep running when using ICE in halt state. The output of Timer2 can be sent to pin PB2, PA3 or PB4, depending on bit [3:2] of `tm2c` register. A clock pre-scaling module is provided with divided-by- 1, 4, 16, and 64 options, controlled by bit [6:5] of `tm2s` register; one scaling module with divided-by-1~31 is also provided and controlled by bit [4:0] of `tm2s` register. In conjunction of pre-scaling function and scaling function, the frequency of Timer2 clock (TM2_CLK) can be wide range and flexible.

The Timer2 counter performs 8-bit up-counting operation only; the counter values can be set or read back by `tm2ct` register. The 8-bit counter will be clear to zero automatically when its values reach for upper bound register, the upper bound register is used to define the period of timer or duty of PWM. There are two operating modes for Timer2: period mode and PWM mode; period mode is used to generate periodical output waveform or interrupt event; PWM mode is used to generate PWM output waveform with optional 6-bit or 8-bit PWM resolution, Fig. 6 shows the timing diagram of Timer2 for both period mode and PWM mode.

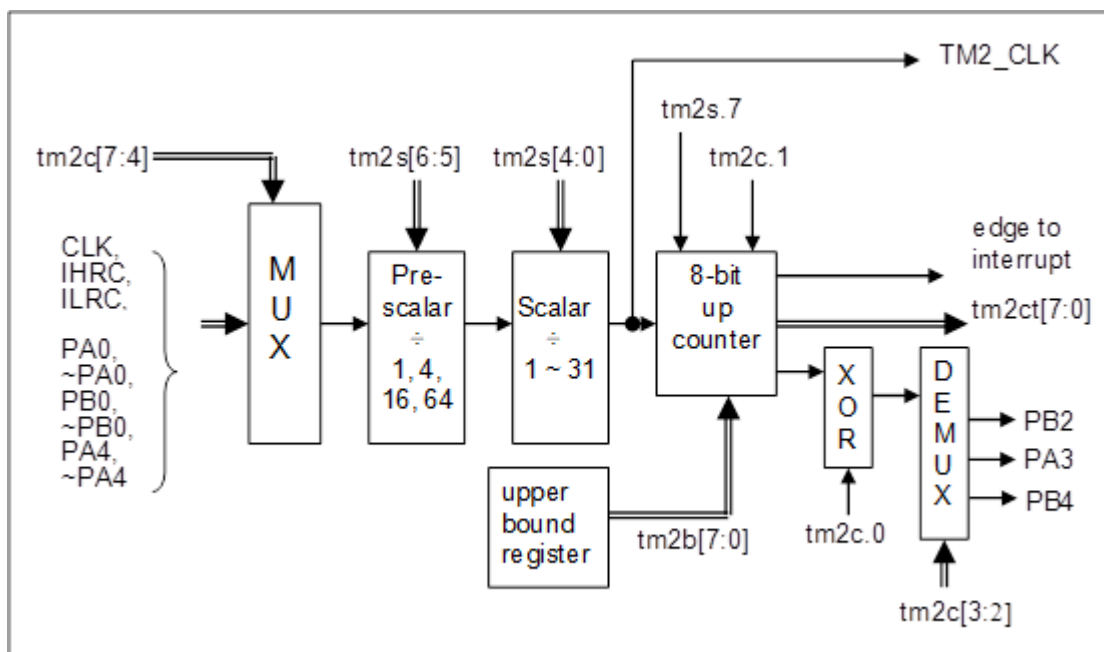

Fig.5: Timer2 hardware diagram

The output of Timer3 can be sent to pin PB5, PB6 or PB7.

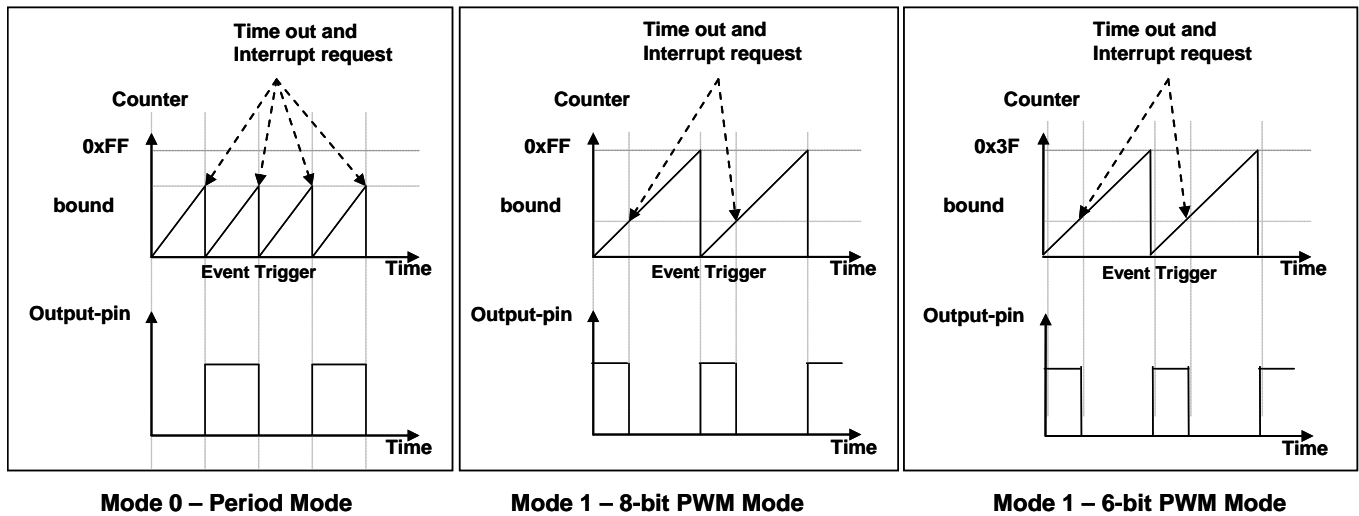

Fig.6: Timing diagram of Timer2 in period mode and PWM mode (tm2c.1=1)

5.6.1. Using the Timer2 to generate periodical waveform

If periodical mode is selected, the duty cycle of output is always 50%; its frequency can be summarized as below:

$$\text{Frequency of Output} = Y \div [2 \times (K+1) \times S1 \times (S2+1)]$$

Where, $Y = \text{tm2c}[7:4]$: frequency of selected clock source

$K = \text{tm2b}[7:0]$: bound register in decimal

$S1 = \text{tm2s}[6:5]$: pre-scalar ($S1 = 1, 4, 16, 64$)

$S2 = \text{tm2s}[4:0]$: scalar register in decimal ($S2 = 0 \sim 31$)

Example 1:

$\text{tm2c} = 0b0001_1000$, $Y=8\text{MHz}$

$\text{tm2b} = 0b0111_1111$, $K=127$

$\text{tm2s} = 0b0_00_00000$, $S1=1$, $S2=0$

→ frequency of output = $8\text{MHz} \div [2 \times (127+1) \times 1 \times (0+1)] = 31.25\text{kHz}$

Example 2:

$\text{tm2c} = 0b0001_1000$, $Y=8\text{MHz}$

$\text{tm2b} = 0b0111_1111$, $K=127$

$\text{tm2s}[7:0] = 0b0_11_11111$, $S1=64$, $S2 = 31$

→ frequency = $8\text{MHz} \div (2 \times (127+1) \times 64 \times (31+1)) = 15.25\text{Hz}$

Example 3:

tm2c = 0b0001_1000, Y=8MHz

tm2b = 0b0000_1111, K=15

tm2s = 0b0_00_00000, S1=1, S2=0

→ frequency = 8MHz ÷ (2 × (15+1) × 1 × (0+1)) = 250kHz

Example 4:

tm2c = 0b0001_1000, Y=8MHz

tm2b = 0b0000_0001, K=1

tm2s = 0b0_00_00000, S1=1, S2=0

→ frequency = 8MHz ÷ (2 × (1+1) × 1 × (0+1)) =2MHz

The sample program for using the Timer2 to generate periodical waveform from PA3 is shown as below:

```

Void FPPA0 (void)
{
    . ADJUST_IC      SYSCLK=IHRC/2, IHRC=16MHz, VDD=5V
    ...
    tm2ct = 0x00;
    tm2b = 0x7f;
    tm2s = 0b0_00_00001;           // 8-bit PWM, pre-scalar = 1, scalar = 2
    tm2c = 0b0001_10_0_0;         // system clock, output=PA3, period mode
    while(1)
    {
        nop;
    }
}

```

5.6.2. Using the Timer2 to generate 8-bit PWM waveform

If 8-bit PWM mode is selected, it should set $tm2c[1]=1$ and $tm2s[7]=0$, the frequency and duty cycle of output waveform can be summarized as below:

$$\text{Frequency of Output} = Y \div [256 \times S1 \times (S2+1)]$$

$$\text{Duty of Output} = [(K+1) \div 256] \times 100\%$$

Where, $Y = tm2c[7:4]$: frequency of selected clock source

$K = tm2b[7:0]$: bound register in decimal

$S1 = tm2s[6:5]$: pre-scalar ($S1 = 1, 4, 16, 64$)

$S2 = tm2s[4:0]$: scalar register in decimal ($S2 = 0 \sim 31$)

Example 1:

$tm2c = 0b0001_1010$, $Y=8\text{MHz}$

$tm2b = 0b0111_1111$, $K=127$

$tm2s = 0b0_00_00000$, $S1=1$, $S2=0$

→ frequency of output = $8\text{MHz} \div (256 \times 1 \times (0+1)) = 31.25\text{kHz}$

→ duty of output = $[(127+1) \div 256] \times 100\% = 50\%$

Example 2:

$tm2c = 0b0001_1010$, $Y=8\text{MHz}$

$tm2b = 0b0111_1111$, $K=127$

$tm2s = 0b0_11_11111$, $S1=64$, $S2=31$

→ frequency of output = $8\text{MHz} \div (256 \times 64 \times (31+1)) = 15.25\text{Hz}$

→ duty of output = $[(127+1) \div 256] \times 100\% = 50\%$

Example 3:

$tm2c = 0b0001_1010$, $Y=8\text{MHz}$

$tm2b = 0b1111_1111$, $K=255$

$tm2s = 0b0_00_00000$, $S1=1$, $S2=0$

→ PWM output keep high

→ duty of output = $[(255+1) \div 256] \times 100\% = 100\%$

Example 4:

$tm2c = 0b0001_1010$, $Y=8\text{MHz}$

$tm2b = 0b0000_1001$, $K = 9$

$tm2s = 0b0_00_00000$, $S1=1$, $S2=0$

→ frequency of output = $8\text{MHz} \div (256 \times 1 \times (0+1)) = 31.25\text{kHz}$

→ duty of output = $[(9+1) \div 256] \times 100\% = 3.9\%$

The sample program for using the Timer2 to generate PWM waveform from PA2 is shown as below:

```
void FPPA0 (void)
{
    .ADJUST_IC    SYSCLK=IHRC/2, IHRC=16MHz, VDD=5V
    wdreset;
    tm2ct = 0x00;
    tm2b = 0x7f;
    tm2s = 0b_00_00001;           // 8-bit PWM, pre-scalar = 1, scalar = 2
    tm2c = 0b0001_10_1_0;       // system clock, output=PA3, PWM mode
    while(1)
    {
        nop;
    }
}
```

5.6.3. Using the Timer2 to generate 6-bit PWM waveform

If 6-bit PWM mode is selected, it should set **tm2c[1]=1** and **tm2s[7]=1**, the frequency and duty cycle of output waveform can be summarized as below:

$$\text{Frequency of Output} = Y \div [64 \times S1 \times (S2+1)]$$

$$\text{Duty of Output} = [(K+1) \div 64] \times 100\%$$

Where, tm2c[7:4] = Y : frequency of selected clock source

tm2b[7:0] = K : bound register in decimal

tm2s[6:5] = S1 : pre-scalar (S1= 1, 4, 16, 64)

tm2s[4:0] = S2 : scalar register in decimal (S2= 0 ~ 31)

Example 1:

tm2c = 0b0001_1010, Y=8MHz

tm2b = 0b0001_1111, K=31

tm2s = 0b1_00_00000, S1=1, S2=0

→ frequency of output = 8MHz ÷ (64 × 1 × (0+1)) = 125kHz

→ duty = [(31+1) ÷ 64] × 100% = 50%

Example 2:

tm2c = 0b0001_1010, Y=8MHz

tm2b = 0b0001_1111, K=31

tm2s = 0b1_11_11111, S1=64, S2=31

→ frequency of output = 8MHz ÷ (64 × 64 × (31+1)) = 61.03 Hz

→ duty of output = [(31+1) ÷ 64] × 100% = 50%

Example 3:

tm2c = 0b0001_1010, Y=8MHz
 tm2b = 0b0011_1111, K=63
 tm2s = 0b1_00_00000, S1=1, S2=0
 → PWM output keep high
 → duty of output = $[(63+1) \div 64] \times 100\% = 100\%$

Example 4:

tm2c = 0b0001_1010, Y=8MHz
 tm2b = 0b0000_0000, K=0
 tm2s = 0b1_00_00000, S1=1, S2=0
 → frequency = $8\text{MHz} \div (64 \times 1 \times (0+1)) = 125\text{kHz}$
 → duty = $[(0+1) \div 64] \times 100\% = 1.5\%$

5.7. WatchDog Timer

The watchdog timer (WDT) is a counter with clock coming from ILRC and there are four different timeout periods of watchdog timer to be chosen by setting the *misc* register, it is:

- ◆ 256 ILRC clocks period if register misc[1:0]=11
- ◆ 2048 ILRC clocks period if register misc[1:0]=00 (default)
- ◆ 4096 ILRC clocks period if register misc[1:0]=01
- ◆ 16384 ILRC clocks period if register misc[1:0]=10

The frequency of ILRC may drift a lot due to the variation of manufacture, supply voltage and temperature; user should reserve guard band for save operation. WDT can be cleared by power-on-reset or by command *wdreset* at any time. When WDT is timeout, PMC131/PMS131/PMS130 will be reset to restart the program execution. The relative timing diagram of watchdog timer is shown as Fig. 7.

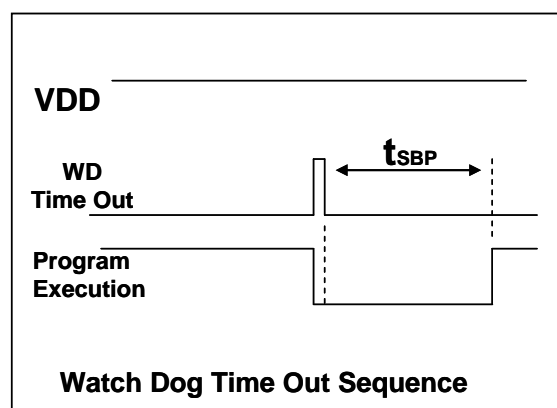

Fig.7: Sequence of Watch Dog Time Out

5.8. Interrupt

There are eight interrupt lines for PMC131/PMS131/PMS130:

- ◆ External interrupt PA0/PB5
- ◆ External interrupt PB0/PA4
- ◆ ADC interrupt
- ◆ Timer16 interrupt
- ◆ Timer2 interrupt
- ◆ Timer3 interrupt

Every interrupt request line has its own corresponding interrupt control bit to enable or disable it; the hardware diagram of interrupt function is shown as Fig. 8. All the interrupt request flags are set by hardware and cleared by writing *intrq* register. When the request flags are set, it can be rising edge, falling edge or both, depending on the setting of register *integs*. All the interrupt request lines are also controlled by *engint* instruction (enable global interrupt) to enable interrupt operation and *disgint* instruction (disable global interrupt) to disable it.

The stack memory for interrupt is shared with data memory and its address is specified by stack register *sp*. Since the program counter is 16 bits width, the bit 0 of stack register *sp* should be kept 0. Moreover, user can use *pushaf* / *popaf* instructions to store or restore the values of *ACC* and *flag* register *to* / *from* stack memory. Since the stack memory is shared with data memory, the stack position and level are arranged by the compiler in Mini-C project. When defining the stack level in ASM project, users should arrange their locations carefully to prevent address conflicts.

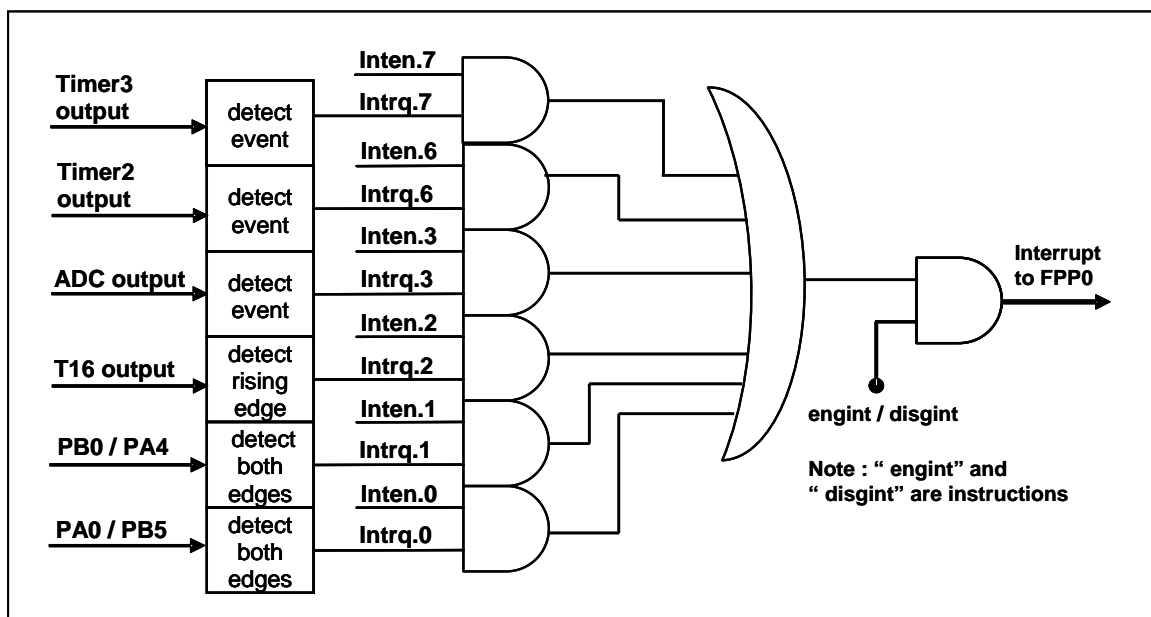

Fig.8: Hardware diagram of interrupt controller

Once the interrupt occurs, its operation will be:

- ◆ The program counter will be stored automatically to the stack memory specified by register *sp*.
- ◆ New *sp* will be updated to *sp+2*.
- ◆ Global interrupt will be disabled automatically.
- ◆ The next instruction will be fetched from address 0x010.

During the interrupt service routine, the interrupt source can be determined by reading the *intrq* register.

Note: Even if *INTEN=0*, *INTRQ* will be still triggered by the interrupt source.

After finishing the interrupt service routine and issuing the *reti* instruction to return back, its operation will be:

- ◆ The program counter will be restored automatically from the stack memory specified by register *sp*.
- ◆ New *sp* will be updated to *sp-2*.
- ◆ Global interrupt will be enabled automatically.
- ◆ The next instruction will be the original one before interrupt.

User must reserve enough stack memory for interrupt, two bytes stack memory for one level interrupt and four bytes for two levels interrupt. And so on, two bytes stack memory is for *pushaf*. For interrupt operation, the following sample program shows how to handle the interrupt, noticing that it needs four bytes stack memory to handle one level interrupt and *pushaf*.

```
void FPPA0 (void)
{
    ...
    $ INTEN PA0;      // INTEN =1; interrupt request when PA0 level changed
    INTRQ = 0;        // clear INTRQ
    ENGINT            // global interrupt enable
    ...
    DISGINT          // global interrupt disable
    ...
}
```

```

void Interrupt (void)           // interrupt service routine
{
    PUSHAF                      // store ALU and FLAG register

    // If INTEN.PA0 will be opened and closed dynamically,
    // user can judge whether INTEN.PA0 =1 or not.
    // Example: If (INTEN.PA0 && INTRQ.PA0) {...}

    // If INTEN.PA0 is always enable,
    // user can omit the INTEN.PA0 judgement to speed up interrupt service routine.

    If (INTRQ.PA0)
    {
        // Here for PA0 interrupt service routine
        INTRQ.PA0 = 0;          // Delete corresponding bit (take PA0 for example)
        ...
    }
    ...
    // X : INTRQ = 0;           // It is not recommended to use INTRQ = 0 to clear all at the end of the
                                // interrupt service routine.
                                // It may accidentally clear out the interrupts that have just occurred
                                // and are not yet processed.

    POPAF                       // restore ALU and FLAG register
}

```

5.9. Power-Save and Power-Down

There are three operational modes defined by hardware: ON mode, Power-Save mode and Power-Down modes. ON mode is the state of normal operation with all functions ON, Power-save mode (“*stopexe*”) is the state to reduce operating current and CPU keeps ready to continue, Power-Down mode (“*stopsys*”) is used to save power deeply. Therefore, Power-save mode is used in the system which needs low operating power with wake-up occasionally and Power-Down mode is used in the system which needs power down deeply with seldom wake-up. Fig. 9 shows the differences in oscillator modules between Power-Save mode (“*stopexe*”) and Power-Down mode (“*stopsys*”).

Differences in oscillator modules between STOPSYS and STOPEXE			
	IHRC	ILRC	EOSC
STOPSYS	Stop	Stop	Stop
STOPEXE	No Change	No Change	No Change

Fig.9: Differences in oscillator modules between STOPSYS and STOPEXE

5.9.1. Power-Save mode (“*stopexe*”)

Using “*stopexe*” instruction to enter the Power-Save mode, only system clock is disabled, remaining all the oscillator modules active. For CPU, it stops executing; however, for Timer16, counter keep counting if its clock source is not the system clock. The wake-up sources for “*stopexe*” can be IO-toggle or Timer16 counts to set values when the clock source of Timer16 is IHRC or ILRC modules. Wake-up from input pins can be considered as a continuation of normal execution, the detail information for Power-Save mode shown below:

- IHRC and EOSC oscillator modules: No change, keep active if it was enabled
- ILRC oscillator modules: must remain enabled, need to start with ILRC when be wakening up
- System clock: Disable, therefore, CPU stops execution
- OTP memory is turned off
- Timer counter: Stop counting if its clock source is system clock or the corresponding oscillator module is disabled; otherwise, it keeps counting. (The Timer contains TM16, TM2, TM3.)
- Wake-up sources:
 - a. IO toggle wake-up: IO toggling in digital input mode (*PAC* bit is 1 and *PADIER* bit is 1)
 - b. Timer wake-up: If the clock source of Timer is not the SYSClk, the system will be awakened when the Timer counter reaches the set value.

The watchdog timer must be disabled before issuing the “*stopexe*” command, the example is shown as below:

```

CLKMD.En_WatchDog = 0;           // disable watchdog timer
stopexe;
nop;
....                               // power saving
Wdreset;
CLKMD.En_WatchDog = 1;           // enable watchdog timer

```

Another example shows how to use Timer16 to wake-up from “*stopexe*”:

```

$ T16M    IHRC, /1, BIT8           // Timer16 setting
...
WORD     count = 0;
STT16    count;
stopexe;

```

nop;

...

The initial counting value of Timer16 is zero and the system will be woken up after the Timer16 counts 256 IHRC clocks.

5.9.2. Power-Down mode (“*stopsys*”)

Power-Down mode is the state of deeply power-saving with turning off all the oscillator modules. By using the “*stopsys*” instruction, this chip will be put on Power-Down mode directly. The internal low frequency RC oscillator must be enabled before entering the Power-Down mode, means that bit 2 of register *clkmd* (0x03) must be set to high before issuing “*stopsys*” command in order to resume the system when wakeup. The following shows the internal status of PMC131/PMS131/PMS130 detail when “*stopsys*” command is issued:

- All the oscillator modules are turned off
- Enable internal low RC oscillator (set bit 2 of register *clkmd*)
- OTP memory is turned off
- The contents of SRAM and registers remain unchanged
- Wake-up sources: IO toggle in digital mode (PxDIER bit is 1)

Wake-up from input pins can be considered as a continuation of normal execution. To minimize power consumption, all the I/O pins should be carefully manipulated before entering power-down mode. The reference sample program for power down is shown as below:

```

CLKMD    =    0xF4;    //    Change clock from IHRC to ILRC, disable watchdog timer
CLKMD.4  =    0;      //    disable IHRC
...
while (1)
{
    STOPSYS;           //    enter power-down
    if (...) break;    //    if wakeup happen and check OK, then return to high speed,
                        //    else stay in power-down mode again.
}
CLKMD    =    0x34;    //    Change clock from ILRC to IHRC/2

```

5.9.3. Wake-up

After entering the Power-Down or Power-Save modes, the PMC131/PMS131/PMS130 can be resumed to normal operation by toggling IO pins. Wake-up from timer are available for Power-Save mode ONLY. Fig. 10 shows the differences in wake-up sources between STOPSYS and STOPEXE.

Differences in wake-up sources between STOPSYS and STOPEXE		
	IO Toggle	Timer wake-up
STOPSYS	Yes	No
STOPEXE	Yes	Yes

Fig.10: Differences in wake-up sources between Power-Save mode and Power-Down mode

When using the IO pins to wake-up the PMC131/PMS131/PMS130, registers *padier* and *pbdier* should be properly set to enable the wake-up function for every corresponding pin. The wake-up time for normal wake-up is about 1024 ILRC clocks counting from wake-up event; fast wake-up can be selected to reduce the wake-up time by *misc* register. For fast wake-up mechanism, the wake-up time is 128 system clocks from IO toggling if STOPEXE was issued, and 128 system clocks plus oscillator (IHRC or ILRC) stable time from IO toggling if STOPSYS was issued. The oscillator stable time is the time for IHRC or ILRC oscillator from power-on, depending on which oscillator is used as system clock source. Please notice that the fast wake-up will turn off automatically when EOSC is selected as the system clock.

Suspend mode	Wake-up mode	System clock source	Wake-up time (t_{WUP}) from IO toggle
STOPEXE suspend	fast wake-up	IHRC or ILRC	$128 * T_{SYS}$, Where T_{SYS} is the time period of system clock
STOPSYS suspend	fast wake-up	IHRC	$128 T_{SYS} + T_{SIHRC}$; Where T_{SIHRC} is the stable time of IHRC from power-on.
STOPSYS suspend	fast wake-up	ILRC	$128 T_{SYS} + T_{SILRC}$; Where T_{SILRC} is the stable time of ILRC from power-on.
STOPSYS or STOPEXE suspend	fast wake-up	EOSC	$1024 * T_{ILRC}$, Where T_{ILRC} is the clock period of ILRC
STOPEXE suspend	normal wake-up	Any one	$1024 * T_{ILRC}$, Where T_{ILRC} is the clock period of ILRC
STOPSYS suspend	normal wake-up	Any one	$1024 * T_{ILRC}$, Where T_{ILRC} is the clock period of ILRC

** Please notice that the clock source of watch-dog will be switched to system clock (for example: 4MHz) when fast wakeup is enabled. Therefore, for fast wake-up, recommending turning off the watchdog timer **before** enabling the fast wakeup. When wake-up, turning on the watchdog timer **after** disabling the fast wakeup.

5.10. IO Pins

Other than PA5, all the pins can be independently set into two states output or input by configuring the data registers (*pa*, *pb*), control registers (*pac*, *pbcb*) and pull-high registers (*paph*, *pbph*). All these pins have Schmitt-trigger input buffer and output driver with CMOS level. When it is set to output low, the pull-up resistor is turned off automatically. If user wants to read the pin state, please notice that it should be set to input mode before reading the data port; if user reads the data port when it is set to output mode, the reading data comes from data register, NOT from IO pad. As an example, Table 5 shows the configuration table of bit 0 of port A. The hardware diagram of IO buffer is also shown as Fig. 11.

<i>pa.0</i>	<i>pac.0</i>	<i>paph.0</i>	Description
X	0	0	Input without pull-up resistor
X	0	1	Input with pull-up resistor
0	1	X	Output low without pull-up resistor
1	1	0	Output high without pull-up resistor
1	1	1	Output high with pull-up resistor

Table 5: PA0 Configuration Table

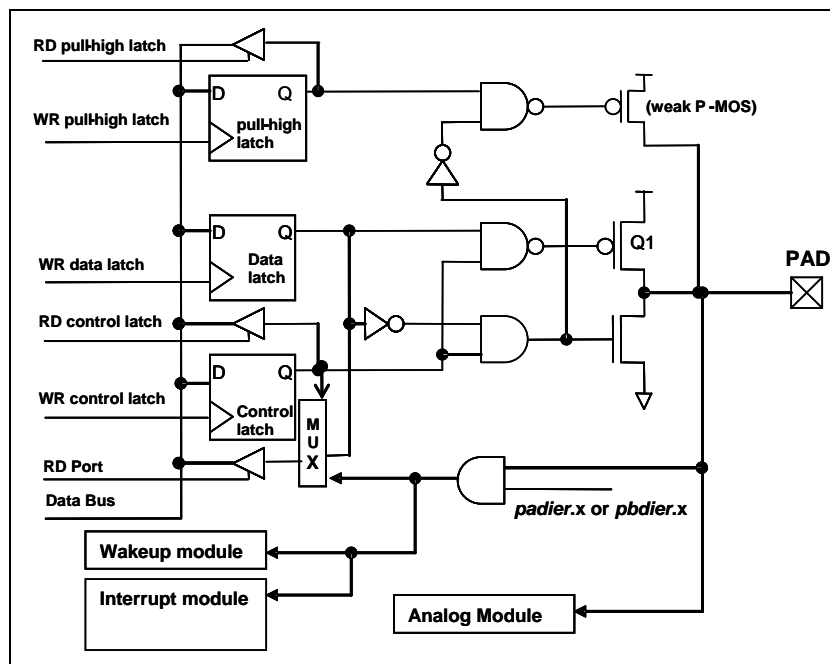

Fig.11: Hardware diagram of IO buffer

Other than PA5, all the IO pins have the same structure; PA5 can be open-drain ONLY when setting to output mode (without Q1). The corresponding bits in registers *padier* / *pbdier* should be set to low to prevent leakage current for those pins are selected to be analog function. When PMC131/PMS131/PMS130 is put in power-down or power-save mode, every pin can be used to wake-up system by toggling its state. Therefore, those pins needed to wake-up system must be set to input mode and set the corresponding bits of registers *padier* and *pbdier* to high. The same reason, *padier.0* should be set high when PA0 is used as external interrupt pin, *pbdier.0* for PB0, *padier.4* for PA4 and *pbdier.5* for PB5.

5.11. Reset and LVR

5.11.1. Reset

There are many causes to reset the PMC131/PMS131/PMS130, once reset is asserted, most of all the registers in PMC131/PMS131/PMS130 will be set to default values. System should be restarted once abnormal cases happen, or by jumping program counter to address 0X0. The data memory is in uncertain state when reset comes from power-up and LVR; however, the content will be kept when reset comes from PRSTB pin or WDT timeout.

5.11.2. LVR reset

By code option, there are 8 different levels of LVR for reset: 4.1V, 3.6V, 3.1V, 2.8V, 2.5V, 2.2V, 2.0V and 1.8V; usually, user selects LVR reset level to be in conjunction with operating frequency and supply voltage.

5.12. Analog-to-Digital Conversion (ADC) module

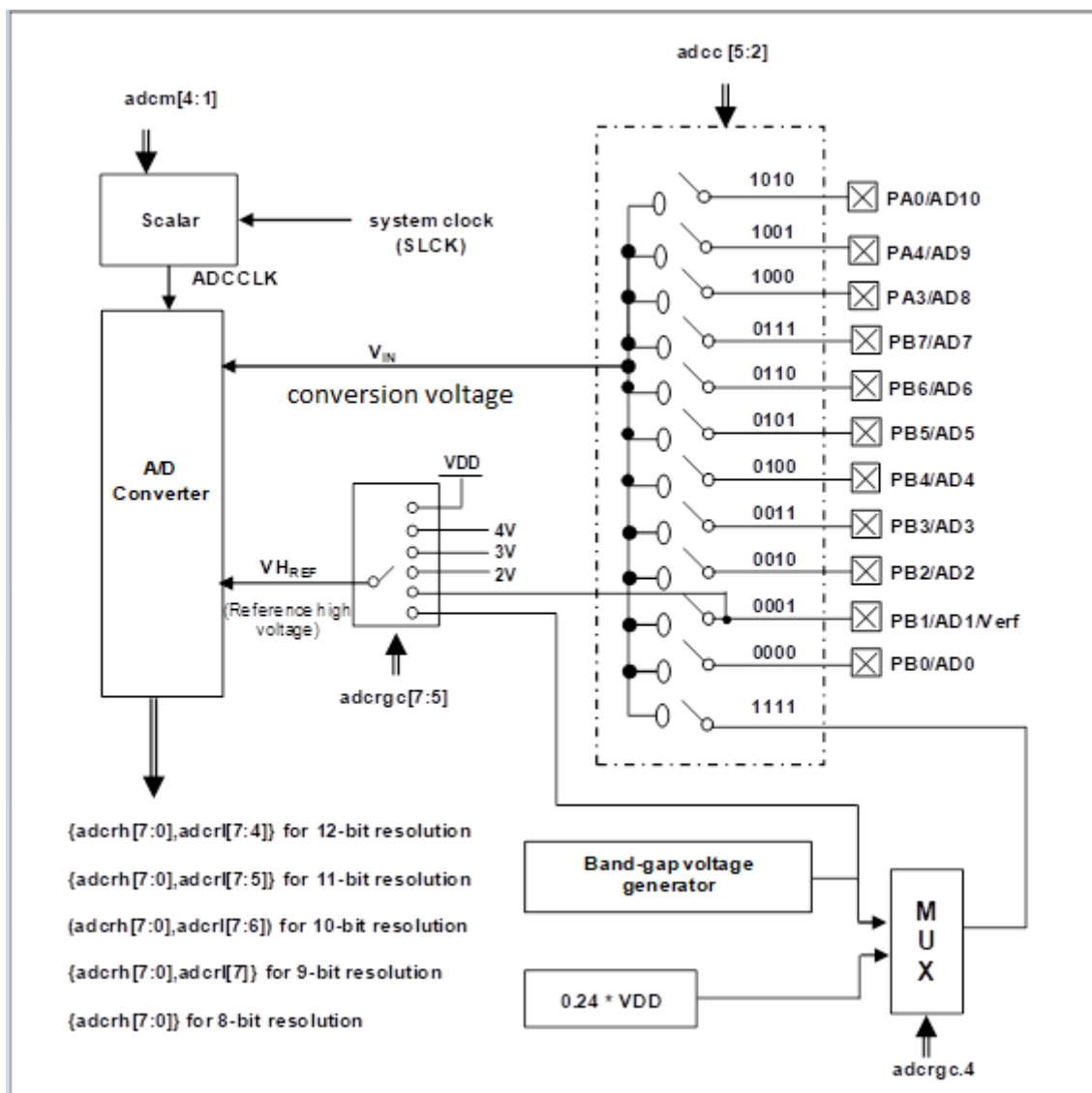

Fig.12: ADC Block Diagram

There are seven registers when using the ADC module, which are:

- ◆ ADC Control Register (***adcc***)
- ◆ ADC Regulator Control Register (***adcrhc***)
- ◆ ADC Mode Register (***adcm***)
- ◆ ADC Result High/Low Register (***adcrh***, ***adcrh***)
- ◆ Port A/B Digital Input Enable Register (***padier***, ***pbdiar***)

The following steps are recommended to do the AD conversion procedure:

(1) Configure the ADC module:

- ◆ Configure the voltage reference high by ***adcrhc*** register
- ◆ Select the ADC input channel by ***adcc*** register
- ◆ Select the bit resolution of ADC by ***adcm*** register
- ◆ Configure the AD conversion clock by ***adcm*** register
- ◆ Configure the pin as analog input by ***padier***, ***pbdiar*** register
- ◆ Enable the ADC module by ***adcc*** register

(2) Configure interrupt for ADC: (if desired)

- ◆ Clear the ADC interrupt request flag in bit 3 of ***intrq*** register
- ◆ Enable the ADC interrupt request in bit 3 of ***inten*** register
- ◆ Enable global interrupt by issuing ***engint*** command

(3) Start AD conversion:

- ◆ Set ADC process control bit in the ***adcc*** register to start the conversion (set1 ***adcc.6***).

(4) Wait for the completion flag of AD conversion, by either:

- ◆ Waiting for the completion flag by check ***adcc.6***; or
- ◆ Waiting for the ADC interrupt.

(5) Read the ADC result registers:

- ◆ Read ***adcrh*** and ***adcrh*** the result registers

(6) For next conversion, goto step 1 or step 2 as required.

5.12.1. The input requirement for AD conversion

For the AD conversion to meet its specified accuracy, the charge holding capacitor (C_{HOLD}) must be allowed to fully charge to the voltage reference high level and discharge to the voltage reference low level. The analog input model is shown as Fig. 13, the signal driving source impedance (R_s) and the internal sampling switch impedance (R_{ss}) will affect the required time to charge the capacitor C_{HOLD} directly. The internal sampling switch impedance may vary with ADC supply voltage; the signal driving source impedance will affect accuracy of analog input signal. User must ensure the measured signal is stable before sampling; therefore, the maximum signal driving source impedance is highly dependent on the frequency of signal to be measured. The recommended maximum impedance for analog driving source is about 10K Ω under 500kHz input frequency and 10-bit resolution requirements, and 10M Ω under 500Hz input frequency and 10-bit resolution.

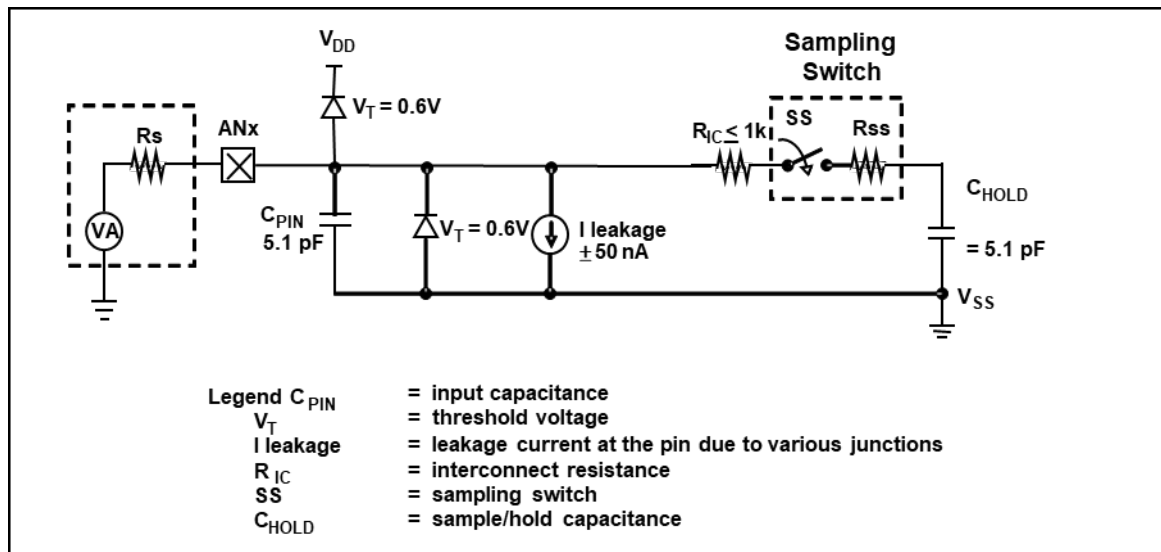

Fig.13: Analog Input Model

Before starting the AD conversion, the minimum signal acquisition time should be met for the selected analog input signal, the selection of ADCLK must be met the minimum signal acquisition time.

5.12.2. Select the ADC bit resolution

The ADC bit resolution is also selectable from 8-bit to 12-bit, depending on the requirement of customers' application. Higher resolution can detect small signal variation; however, it will take more time to convert the analog signal to digital signal. The selection can be done via **adcm** register. The ADC bit resolution should be configured before starting the AD conversion.

5.12.3. Select the reference high voltage

The ADC reference high voltage can be selected via bit[7:5] of register **adcrh** and its option can be VDD, 4V, 3V, 2V, 1.20V band-gap reference voltage or PB1 from external pin.

5.12.4. ADC clock selection

The clock of ADC module (ADCLK) can be selected by **adcm** register; there are 8 possible options for ADCLK from CLK÷1 to CLK÷128 (CLK is the system clock). Due to the signal acquisition time T_{ACQ} is one clock period of ADCLK, the ADCLK must meet that requirement. The recommended ADC clock is to operate at 2us.

5.12.5. AD conversion

The process of AD conversion starts from setting START/DONE bit (bit 6 of **adcc**) to high, the START/DONE flag for read will be cleared automatically, then converting analog signal bit by bit and finally setting START/DONE high to indicate the completion of AD conversion. If ADCLK is selected, T_{ADCLK} is the period of ADCLK and the AD conversion time can be calculated as follows:

- ◆ 8-bit resolution: AD conversion time = 13 T_{ADCLK}
- ◆ 9-bit resolution: AD conversion time = 14 T_{ADCLK}
- ◆ 10-bit resolution: AD conversion time = 15 T_{ADCLK}
- ◆ 11-bit resolution: AD conversion time = 16 T_{ADCLK}
- ◆ 12-bit resolution: AD conversion time = 17 T_{ADCLK}

5.12.6. Configure the analog pins

There are 12 analog signals can be selected for AD conversion, 11 analog input signals come from external pins and one is internal signal 1.2V band-gap reference voltage or $0.24 \cdot V_{DD}$. For external pins, the analog signals are shared with Port A[0], Port A[3], Port A[4], and Port B[7:0]. To avoid leakage current at the digital circuit, those pins defined for analog input should disable the digital input function (set the corresponding bit of **padier or pbdier** register to be 0).

The measurement signals of ADC belong to small signal; it should avoid the measured signal to be interfered during the measurement period, the selected pin should (1) be set to input mode (2) turn off weak pull-high resistor (3) set the corresponding pin to analog input by port A/B digital input disable register (**padier / pbdier**).

5.12.7. Using the ADC

The following example shows how to use ADC with PB0~PB3.

First, defining the selected pins:

```

PBC      =    0B_XXXX_0000;      //    PB0 ~ PB3 as Input
PBPH    =    0B_XXXX_0000;      //    PB0 ~ PB3 without pull-high
$ PBDIER  0B_XXXX_0000;      //    PB0 ~ PB3 digital input is disabled

```

Next, setting **ADCC** register, example as below:

```

$ ADCC Enable, PB3;      //    set PB3 as ADC input
$ ADCC Enable, PB2;      //    set PB2 as ADC input
$ ADCC Enable, PB0;      //    set PB0 as ADC input

```

Next, setting **ADCM** and **ADCRGC** register, example as below:

```

$ ADCM 12BIT, /16;      //    recommend /16 @System Clock=8MHz
$ ADCM 12BIT, /8;       //    recommend /8 @System Clock=4MHz
$ ADCRGC VDD;

```

Then, start the ADC conversion:

```

AD_START = 1; // start ADC conversion
do
{
    Nop;
}while(!AD_DONE); // wait ADC conversion result

```

Finally, it can read ADC result when **AD_DONE** is high:

```

WORD = Data; // two bytes result: ADCRH and ADCRL
Data = (ADCRH << 8) | ADCRL;

```

The ADC can be disabled by using the following method:

```

$ ADCC Disable;

```

or

```

ADCC = 0;

```

5.13. Multiplier

There is an 8x8 multiplier on-chip to enhance hardware capability in arithmetic function, its multiplication is an 8x8 unsigned operation and can be finished in one clock cycle. Before issuing the *mul* command, both multiplicand and multiplier must be put on ACC and register *mulop* (0x08); After *mul* command, the high byte result will be put on register *mulrh* (0x09) and low byte result on ACC. The hardware diagram of this multiplier is shown as Fig.14.

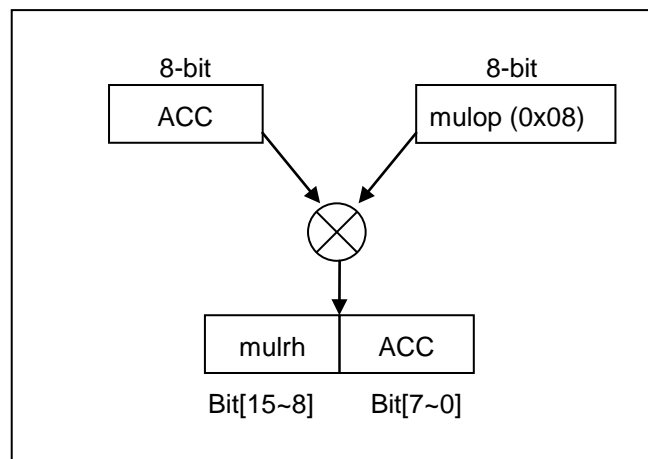

Fig. 14: Block diagram of hardware multiplier

6. IO Registers

6.1. ACC Status Flag Register (*flag*), IO address = 0x00

Bit	Reset	R/W	Description
7 – 4	-	-	Reserved. Please do not use.
3	0	R/W	OV (Overflow Flag). This bit is set to be 1 whenever the sign operation is overflow.
2	0	R/W	AC (Auxiliary Carry Flag). There are two conditions to set this bit, the first one is carry out of low nibble in addition operation and the other one is borrow from the high nibble into low nibble in subtraction operation.
1	0	R/W	C (Carry Flag). There are two conditions to set this bit, the first one is carry out in addition operation, and the other one is borrow in subtraction operation. Carry is also affected by shift with carry instruction.
0	0	R/W	Z (Zero Flag). This bit will be set when the result of arithmetic or logic operation is zero; Otherwise, it is cleared.

6.2. Stack Pointer Register (*sp*), IO address = 0x02

Bit	Reset	R/W	Description
7 – 0	-	R/W	Stack Pointer Register. Read out the current stack pointer, or write to change the stack pointer.

6.3. Clock Mode Register (*clkmd*), IO address = 0x03

Bit	Reset	R/W	Description
7 – 5	111	R/W	System clock (CLK) selection:
			Type 0, clkmd[3]=0
			000: IHRC÷4 001: IHRC÷2 010: reserved 011: EOSC÷4 100: EOSC÷2 101: EOSC 110: ILRC÷4 111: ILRC (default)
			000: IHRC÷16 001: IHRC÷8 010: reserved 011: IHRC÷32 100: IHRC÷64 101: EOSC÷8 11x: reserved
4	1	R/W	Internal High RC Enable. 0 / 1: disable / enable
3	0	RW	Clock Type Select. This bit is used to select the clock type in bit [7:5]. 0 / 1: Type 0 / Type 1.
2	1	R/W	Internal Low RC Enable. 0 / 1: disable / enable If ILRC is disabled, watchdog timer is also disabled.
1	1	R/W	Watch Dog Enable. 0 / 1: disable / enable
0	0	R/W	Pin PA5/PRSTB function. 0 / 1: PA5 / PRSTB .

6.4. Interrupt Enable Register (*inten*), IO address = 0x04

Bit	Reset	R/W	Description
7	0	R/W	Enable interrupt from Timer3. 0 / 1: disable / enable.
6	0	R/W	Enable interrupt from Timer2. 0 / 1: disable / enable.
5 : 4	-	-	Reserved.
3	0	R/W	Enable interrupt from ADC. 0 / 1: disable / enable.
2	0	R/W	Enable interrupt from Timer16 overflow. 0 / 1: disable / enable.
1	0	R/W	Enable interrupt from PB0/PA4. 0 / 1: disable / enable.
0	0	R/W	Enable interrupt from PA0/PB5. 0 / 1: disable / enable.

6.5. Interrupt Request Register (*intrq*), IO address = 0x05

Bit	Reset	R/W	Description
7	-	R/W	Interrupt Request from Timer3, this bit is set by hardware and cleared by software. 0 / 1: No request / Request
6	-	R/W	Interrupt Request from Timer2, this bit is set by hardware and cleared by software. 0 / 1: No request / Request
5 : 4	-	-	Reserved.
3	-	R/W	Interrupt Request from ADC, this bit is set by hardware and cleared by software. 0 / 1: No request / Request
2	-	R/W	Interrupt Request from Timer16, this bit is set by hardware and cleared by software. 0 / 1: No request / Request
1	-	R/W	Interrupt Request from pin PB0/PA4, this bit is set by hardware and cleared by software. 0 / 1: No request / Request
0	-	R/W	Interrupt Request from pin PA0/PB5, this bit is set by hardware and cleared by software. 0 / 1: No Request / request

6.6. Multiplier Operand Register (*mulop*), IO address = 0x08

Bit	Reset	R/W	Description
7 – 0	-	R/W	Operand for hardware multiplication operation.

6.7. Multiplier Result High Byte Register (*mulrh*), IO address = 0x09

Bit	Reset	R/W	Description
7 – 0	-	RO	High byte result of multiplication operation (read only).

6.8. Timer16 mode Register (*t16m*), IO address = 0x06

Bit	Reset	R/W	Description
7 – 5	000	R/W	Timer16 Clock source selection. 000: disable 001: CLK (system clock) 010: reserved 011: PA4 falling edge (from external pin) 100: IHRC 101: EOSC 110: ILRC 111: PA0 falling edge (from external pin)
4 – 3	00	R/W	Timer16 clock pre-divider. 00: ÷1 01: ÷4 10: ÷16 11: ÷64
2–0	000	R/W	Interrupt source selection. Interrupt event happens when the selected bit status is changed. 0 : bit 8 of Timer16 1 : bit 9 of Timer16 2 : bit 10 of Timer16 3 : bit 11 of Timer16 4 : bit 12 of Timer16 5 : bit 13 of Timer16 6 : bit 14 of Timer16 7 : bit 15 of Timer16

6.9. External Oscillator setting Register (*eoscr*), IO address = 0x0a

Bit	Reset	R/W	Description
7	0	WO	Enable external crystal oscillator. 0 / 1 : Disable / Enable
6 – 5	00	WO	External crystal oscillator selection. 00 : reserved 01 : Low driving capability, for lower frequency, ex: 32kHz crystal oscillator 10 : Middle driving capability, for middle frequency, ex: 1MHz crystal oscillator 11 : High driving capability, for higher frequency, ex: 4MHz crystal oscillator
4 – 1	-	-	Reserved. Please keep 0 for future compatibility.
0	0	WO	Power-down the Band-gap and LVR hardware modules. 0 / 1: normal / power-down.

6.10. Interrupt Edge Select Register (*integs*), IO address = 0x0c

Bit	Reset	R/W	Description
7 – 5	-	-	Reserved.
4	0	WO	Timer16 edge selection. 0 : rising edge of the selected bit to trigger interrupt 1 : falling edge of the selected bit to trigger interrupt
3 – 2	00	WO	PB0/PA4 edge selection. 00 : both rising edge and falling edge of the selected bit to trigger interrupt 01 : rising edge of the selected bit to trigger interrupt 10 : falling edge of the selected bit to trigger interrupt 11 : reserved.
1 – 0	00	WO	PA0/PB5 edge selection. 00 : both rising edge and falling edge of the selected bit to trigger interrupt 01 : rising edge of the selected bit to trigger interrupt 10 : falling edge of the selected bit to trigger interrupt 11 reserved.

6.11. Port A Digital Input Enable Register (*padier*), IO address = 0x0d

Bit	Reset	R/W	Description
7	1	WO	Enable PA7 digital input and wake-up event. 1 / 0 : enable / disable. This bit should be set to low to prevent leakage current when external crystal oscillator is used. If this bit is set to low, PA7 can NOT be used to wake-up the system.
6	1	WO	Enable PA6 digital input and wake-up event. 1 / 0 : enable / disable. This bit should be set to low to prevent leakage current when external crystal oscillator is used. If this bit is set to low, PA6 can NOT be used to wake-up the system.
5	1	WO	Enable PA5 digital input and wake-up event. 1 / 0 : enable / disable. This bit can be set to low to disable wake-up from PA5 toggling.
4	1	WO	Enable PA4 digital input and wake-up event and interrupt request. 1 / 0 : enable / disable. This bit can be set to low to prevent leakage current when PA4 is assigned as AD input, and to disable wake-up from PA4 toggling and interrupt request from this pin.
3	1	WO	Enable PA3 digital input and wake-up event. 1 / 0 : enable / disable. This bit should be set to low when PA3 is assigned as AD input to prevent leakage current. If this bit is set to low, PA3 can NOT be used to wake-up the system.
2 – 0	1	WO	Reserved.
0	1	WO	Enable PA0 digital input and wake-up event and interrupt request. 1 / 0 : enable / disable. This bit can be set to low to prevent leakage current when PA0 is assigned as AD input, and to disable wake-up from PA0 toggling and interrupt request from this pin.

6.12. Port B Digital Input Enable Register (*pbdier*), IO address = 0x0e

Bit	Reset	R/W	Description
7 – 6	11	WO	Enable PB7~PB6 digital input to prevent leakage when the pin is assigned for AD input. When disable is selected, the wakeup function from these pin are also disabled. 0 / 1 : disable / enable
5	1	WO	Enable PB5 digital input and wake-up event and interrupt request. 1 / 0 : enable / disable. This bit can be set to low to prevent leakage current when PB5 is assigned as AD input, and to disable wake-up from PB5 toggling and interrupt request from this pin.
4 - 1	1111	WO	Enable PB4~PB1 digital input to prevent leakage when the pin is assigned for AD input. When disable is selected, the wakeup function from these pin are also disabled. 0 / 1 : disable / enable
0	1	WO	Enable PB0 digital input and wake-up event and interrupt request. 1 / 0 : enable / disable. This bit can be set to low to prevent leakage current when PB0 is assigned as AD input, and to disable wake-up from PB0 toggling and interrupt request from this pin.

6.13. Port A Data Register (*pa*), IO address = 0x10

Bit	Reset	R/W	Description
7 – 0	0x00	R/W	Data register for Port A.

6.14. Port A Control Register (*pac*), IO address = 0x11

Bit	Reset	R/W	Description
7 – 0	0x00	R/W	Port A control registers. This register is used to define input mode or output mode for each corresponding pin of port A. 0 / 1: input / output <u>Please note that PA5 can be INPUT or OUTPUT LOW ONLY, the output state will be tri-state when PA5 is programmed into output mode with data 1.</u>

6.15. Port A Pull-High Register (*paph*), IO address = 0x12

Bit	Reset	R/W	Description
7 – 0	0x00	R/W	Port A pull-high register. This register is used to enable the internal pull-high device on each corresponding pin of port A and this pull high function is active only for input mode. 0 / 1 : disable / enable <u>Please note that PA5 does NOT have pull-up resistor.</u>

6.16. Port B Data Register (*pb*), IO address = 0x14

Bit	Reset	R/W	Description
7 – 0	0x00	R/W	Data register for Port B.

6.17. Port B Control Register (*pbc*), IO address = 0x15

Bit	Reset	R/W	Description
7 – 0	0x00	R/W	Port B control register. This register is used to define input mode or output mode for each corresponding pin of port B. 0 / 1: input / output

6.18. Port B Pull-High Register (*pbph*), IO address = 0x16

Bit	Reset	R/W	Description
7 – 0	0x00	R/W	Port B pull-high register. This register is used to enable the internal pull-high device on each corresponding pin of port B. 0 / 1 : disable / enable

6.19. ADC Control Register (*adcc*), IO address = 0x20

Bit	Reset	R/W	Description
7	0	R/W	Enable ADC function. 0/1: Disable/Enable.
6	0	R/W	ADC process control bit. Write “1” to start AD conversion, and the flag is cleared automatically when starting the AD conversion ; Read “1” to indicate the completion of AD conversion and “0” is in progressing.
5 – 2	0000	R/W	Channel selector. These four bits are used to select input signal for AD conversion. 0000: PB0/AD0, 0001: PB1/AD1, 0010: PB2/AD2, 0011: PB3/AD3, 0100: PB4/AD4, 0101: PB5/AD5, 0110: PB6/AD6, 0111: PB7/AD7, 1000: PA3/AD8, 1001: PA4/AD9, 1010: PA0/AD10, 1111: (Channel F) Band-gap 1.20 volt reference voltage or 0.24*VDD Others: reserved
0 – 1	-	-	Reserved. (keep 0 for future compatibility)

6.20. ADC Regulator Control Register (*adrcg*), IO address = 0x1c

Bit	Reset	R/W	Description
7 – 5	000	WO	These three bits are used to select input signal for ADC reference high voltage. 000: V _{DD} , 001: 2V, 010: 3V, 011: 4V, 100: PB1, 101: Band-gap 1.20 volt reference voltage Others: reserved.
4	0	WO	ADC channel F selector: 0: Band-gap 1.20 volt reference voltage 1: 0.24*VDD. The deviation is within $\pm 0.01 * V_{DD}$ mostly.
3 - 0	-	-	Reserved. Please keep 0.

6.21. ADC Mode Register (*adcm*), IO address = 0x21

Bit	Reset	R/W	Description
7 – 5	000	WO	Bit Resolution. 000:8-bit, AD 8-bit result [7:0] = <i>adcrh</i> [7:0]. 001:9-bit, AD 9-bit result [8:0] = { <i>adcrh</i> [7:0], <i>adcr</i> [7] }. 010:10-bit, AD 10-bit result [9:0] = { <i>adcrh</i> [7:0], <i>adcr</i> [7:6] }. 011:11-bit, AD 11-bit result [10:0] = { <i>adcrh</i> [7:0], <i>adcr</i> [7:5] }. 100:12-bit, AD 12-bit result [11:0] = { <i>adcrh</i> [7:0], <i>adcr</i> [7:4] }. others: reserved.
4	-	-	Reserved (keep 0 for future compatibility)
3 – 1	000	WO	ADC clock source selection. 000: CLK (system clock) ÷ 1, 001: CLK (system clock) ÷ 2, 010: CLK (system clock) ÷ 4, 011: CLK (system clock) ÷ 8, 100: CLK (system clock) ÷ 16, 101: CLK (system clock) ÷ 32, 110: CLK (system clock) ÷ 64, 111: CLK (system clock) ÷ 128,
0	-	-	Reserved.

6.22. ADC Result High Register (*adcrh*), IO address = 0x22

Bit	Reset	R/W	Description
7 – 0	-	RO	These eight read-only bits will be the bit [11:4] of AD conversion result. The bit 7 of this register is the MSB of ADC result for any resolution.

6.23. ADC Result Low Register (*adcr*), IO address = 0x23

Bit	Reset	R/W	Description
7 – 4	-	RO	These four bits will be the bit [3:0] of AD conversion result.
3 – 0	-	-	Reserved.

6.24. Miscellaneous Register (*misc*), IO address = 0x1b

Bit	Reset	R/W	Description
7	-	-	Reserved. (keep 0 for future compatibility)
6	0	WO	Enable extremely low current for 32kHz crystal oscillator AFTER oscillation. 0: Normal. 1: Low driving current for 32kHz crystal oscillator.
5	0	WO	Enable fast Wake-up. Fast wake-up is NOT supported when EOSC is enabled. 0: Normal wake-up. The wake-up time is 1024 ILRC clocks 1: Fast wake-up. The wake-up time is 128 CLKs (system clock) + oscillator stable time. If wake-up from STOPEXE suspend, there is no oscillator stable time; If wake-up from STOPSYS suspend, it will be IHRC or ILRC stable time from power-on. Please notice that the watchdog clock source will be switched to system clock (for example: 4MHz) when fast wakeup is enabled, therefore, it is recommended to turn off the watchdog timer before enabling the fast wakeup and turn on the watchdog timer after disabling the fast wakeup.
4	-	-	Reserved. (keep 0 for future compatibility)
3	0	WO	Recover time from LVR reset. 0: Normal. The system will take about 1024 ILRC clocks to boot up from LVR reset. 1: Fast. The system will take about 64 ILRC clocks to boot up from LVR reset.
2	0	WO	Disable LVR function. 0 / 1 : Enable / Disable
1 – 0	00	WO	Watch dog time out period. 00: 2048 ILRC clock period 01: 4096 ILRC clock period 10: 16384 ILRC clock period 11: 256 ILRC clock period

6.25. Timer2 Control Register (*tm2c*), IO address = 0x3c

Bit	Reset	R/W	Description
7 – 4	0000	R/W	Timer2 clock selection. 0000 : disable 0001 : CLK (system clock) 0010 : IHRC 0011 : reserved 0100 : ILRC 0101 – 011x : reserved 1000 : PA0 (rising edge) 1001 : ~PA0 (falling edge) 1010 : PB0 (rising edge) 1011 : ~PB0 (falling edge) 1100 : PA4 (rising edge) 1101 : ~PA4 (falling edge) Notice: In ICE mode and IHRC is selected for Timer2 clock, <u>the clock sent to Timer2 does NOT be stopped, Timer2 will keep counting when ICE is in halt state.</u>
3 – 2	00	R/W	Timer2 output selection. 00 : disable 01 : PB2 10 : PA3 11 : PB4
1	0	R/W	Timer2 mode selection. 0 / 1 : period mode / PWM mode
0	0	R/W	Enable to inverse the polarity of Timer2 output. 0 / 1: disable / enable.

6.26. Timer2 Counter Register (*tm2ct*), IO address = 0x3d

Bit	Reset	R/W	Description
7 – 0	0x00	WO	Bit [7:0] of Timer2 counter register.

6.27. Timer2 Scalar Register (*tm2s*), IO address = 0x37

Bit	Reset	R/W	Description
7	0	WO	PWM resolution selection. 0 : 8-bit 1 : 6-bit
6 – 5	00	WO	Timer2 clock pre-scalar. 00 : ÷ 1 01 : ÷ 4 10 : ÷ 16 11 : ÷ 64
4 – 0	00000	WO	Timer2 clock scalar.

6.28. Timer2 Bound Register (*tm2b*), IO address = 0x09

Bit	Reset	R/W	Description
7 – 0	0x00	WO	Timer2 bound register.

6.29. Timer3 Control Register (*tm3c*), IO address = 0x2e

Bit	Reset	R/W	Description
7 – 4	0000	R/W	Timer3 clock selection. 0000 : disable 0001 : CLK (system clock) 0010 : IHRC 0011 : reserved 0100 : ILRC 0101 : reserved 011x : reserved 1000 : PA0 (rising edge) 1001 : ~PA0 (falling edge) 1010 : PB0 (rising edge) 1011 : ~PB0 (falling edge) 1100 : PA4 (rising edge) 1101 : ~PA4 (falling edge) Notice: In ICE mode and IHRC is selected for Timer3 clock, <u>the clock sent to Timer3 does NOT be stopped, Timer3 will keep counting when ICE is in halt state.</u>
3 – 2	00	R/W	Timer3 output selection. 00 : disable 01 : PB5 10 : PB6 11 : PB7
1	0	R/W	Timer3 mode selection. 0 / 1 : period mode / PWM mode
0	0	R/W	Enable to inverse the polarity of Timer3 output. 0 / 1: disable / enable.

6.30. Timer3 Counter Register (*tm3ct*), IO address = 0x2f

Bit	Reset	R/W	Description
7 – 0	0x00	WO	Bit [7:0] of Timer3 counter register.

6.31. Timer3 Scalar Register (*tm3s*), IO address = 0x39

Bit	Reset	R/W	Description
7	0	WO	PWM resolution selection. 0 : 8-bit 1 : 6-bit
6 – 5	00	WO	Timer3 clock pre-scalar. 00 : ÷ 1 01 : ÷ 4 10 : ÷ 16 11 : ÷ 64
4 – 0	00000	WO	Timer3 clock scalar.

6.32. Timer3 Bound Register (*tm3b*), IO address = 0x23

Bit	Reset	R/W	Description
7 – 0	0x00	WO	Timer3 bound register.

6.33. RESET Status Register (*rstst*), IO address = 0x25

Bit	Reset	R/W	Description
7 – 4	-	-	Reserved.
3	-	R/W	The reset flag for the external reset pin (PA5). This bit is 1 when PA5 reset occurs. Write 0 to clear this flag.
2	-	R/W	VDD below 4V flag. This bit is 1 when the VDD voltage is lower than 4V. Write 0 to clear this flag. Please note that this bit will be 1 automatically when VDD is powered slowly. If necessary, it is recommended to clear this flag during the program initialization.
1	-	R/W	VDD below 3V flag. This bit is 1 when the VDD voltage is lower than 3V. Write 0 to clear this flag. Please note that this bit will be 1 automatically when VDD is powered slowly. If necessary, it is recommended to clear this flag during the program initialization.
0	-	R/W	VDD below 2V flag. This bit is 1 when the VDD voltage is lower than 2V. Write 0 to clear this flag. Please note that this bit will be 1 automatically when VDD is powered slowly. If necessary, it is recommended to clear this flag during the program initialization.

7. Instructions

Symbol	Description
ACC	Accumulator (Abbreviation of accumulator)
a	Accumulator (symbol of accumulator in program)
sp	Stack pointer
flag	ACC status flag register
I	Immediate data
&	Logical AND
 	Logical OR
←	Movement
^	Exclusive logic OR
+	Add
−	Subtraction
~	NOT (logical complement, 1's complement)
¯	NEG (2's complement)
OV	Overflow (The operational result is out of range in signed 2's complement number system)
Z	Zero (If the result of ALU operation is zero, this bit is set to 1)
C	Carry (The operational result is to have carry out for addition or to borrow carry for subtraction in unsigned number system)
AC	Auxiliary Carry (If there is a carry out from low nibble after the result of ALU operation, this bit is set to 1)
pc0	Program counter for CPU
word	Only addressed in 0~0x1F (0~31) is allowed
M.n	Only addressed in 0~0xF (0~15) is allowed

7.1. Data Transfer Instructions

<i>mov</i> a, I	<p>Move immediate data into ACC. Example: <i>mov</i> a, 0x0f; Result: a ← 0fh; Affected flags: [N] Z [N] C [N] AC [N] OV</p>
<i>mov</i> M, a	<p>Move data from ACC into memory Example: <i>mov</i> MEM, a; Result: MEM ← a Affected flags: [N] Z [N] C [N] AC [N] OV</p>
<i>mov</i> a, M	<p>Move data from memory into ACC Example: <i>mov</i> a, MEM ; Result: a ← MEM; Flag Z is set when MEM is zero. Affected flags: [Y] Z [N] C [N] AC [N] OV</p>
<i>mov</i> a, IO	<p>Move data from IO into ACC Example: <i>mov</i> a, pa ; Result: a ← pa; Flag Z is set when pa is zero. Affected flags: [Y] Z [N] C [N] AC [N] OV</p>
<i>mov</i> IO, a	<p>Move data from ACC into IO Example: <i>mov</i> pb, a; Result: pb ← a Affected flags: [N] Z [N] C [N] AC [N] OV</p>
<i>ldt16</i> word	<p>Move 16-bit counting values in Timer16 to memory in word. Example: <i>ldt16</i> word; Result: word ← 16-bit timer Affected flags: [N] Z [N] C [N] AC [N] OV</p> <p>Application Example:</p> <pre> ----- word T16val ; // declare a RAM word ... clear lb@ T16val ; // clear T16val (LSB) clear hb@ T16val ; // clear T16val (MSB) stt16 T16val ; // initial T16 with 0 ... set1 t16m.5 ; // enable Timer16 ... set0 t16m.5 ; // disable Timer 16 ldt16 T16val ; // save the T16 counting value to T16val ----- </pre>
<i>stt16</i> word	<p>Store 16-bit data from memory in word to Timer16. Example: <i>stt16</i> word; Result: 16-bit timer ← word Affected flags: [N] Z [N] C [N] AC [N] OV</p>

	<p>Application Example:</p> <pre> ----- word T16val ; // declare a RAM word ... mov a, 0x34 ; mov lb@ T16val , a ; // move 0x34 to T16val (LSB) mov a, 0x12 ; mov hb@ T16val , a ; // move 0x12 to T16val (MSB) stt16 T16val ; // initial T16 with 0x1234 ... ----- </pre>
<i>idxm</i> a, index	<p>Move data from specified memory to ACC by indirect method. It needs 2T to execute this instruction.</p> <p>Example: <i>idxm</i> a, index;</p> <p>Result: a ← [index], where index is declared by word.</p> <p>Affected flags: [N] Z [N] C [N] AC [N] OV</p> <p>Application Example:</p> <pre> ----- word RAMIndex ; // declare a RAM pointer ... mov a, 0x5B ; // assign pointer to an address (LSB) mov lb@RAMIndex, a ; // save pointer to RAM (LSB) mov a, 0x00 ; // assign 0x00 to an address (MSB), should be 0 mov hb@RAMIndex, a ; // save pointer to RAM (MSB) ... idxm a, RAMIndex ; // mov memory data in address 0x5B to ACC ----- </pre>
<i>ldxm</i> index, a	<p>Move data from ACC to specified memory by indirect method. It needs 2T to execute this instruction.</p> <p>Example: <i>ldxm</i> index, a;</p> <p>Result: [index] ← a; where index is declared by word.</p> <p>Affected flags: [N] Z [N] C [N] AC [N] OV</p> <p>Application Example:</p> <pre> ----- word RAMIndex ; // declare a RAM pointer ... mov a, 0x5B ; // assign pointer to an address (LSB) mov lb@RAMIndex, a ; // save pointer to RAM (LSB) mov a, 0x00 ; // assign 0x00 to an address (MSB), should be 0 mov hb@RAMIndex, a ; // save pointer to RAM (MSB) ... mov a, 0xA5 ; ldxm RAMIndex, a ; // mov 0xA5 to memory in address 0x5B ----- </pre>

<i>xch</i> M	Exchange data between ACC and memory Example: <i>xch</i> MEM ; Result: MEM ← a , a ← MEM Affected flags: [N] Z [N] C [N] AC [N] OV
<i>pushaf</i>	Move the ACC and flag register to memory that address specified in the stack pointer. Example: <i>pushaf</i> ; Result: [sp] ← {flag, ACC}; sp ← sp + 2 ; Affected flags: [N] Z [N] C [N] AC [N] OV Application Example: ----- .romadr 0x10 ; // ISR entry address <i>pushaf</i> ; // put ACC and flag into stack memory ... // ISR program ... // ISR program <i>popaf</i> ; // restore ACC and flag from stack memory <i>reti</i> ; -----
<i>popaf</i>	Restore ACC and flag from the memory which address is specified in the stack pointer. Example: <i>popaf</i> ; Result: sp ← sp - 2 ; {Flag, ACC} ← [sp] ; Affected flags: [Y] Z [Y] C [Y] AC [Y] OV

7.2. Arithmetic Operation Instructions

<i>add</i> a, I	Add immediate data with ACC, then put result into ACC Example: <i>add</i> a, 0x0f ; Result: a ← a + 0fh Affected flags: [Y] Z [Y] C [Y] AC [Y] OV
<i>add</i> a, M	Add data in memory with ACC, then put result into ACC Example: <i>add</i> a, MEM ; Result: a ← a + MEM Affected flags: [Y] Z [Y] C [Y] AC [Y] OV
<i>add</i> M, a	Add data in memory with ACC, then put result into memory Example: <i>add</i> MEM, a ; Result: MEM ← a + MEM Affected flags: [Y] Z [Y] C [Y] AC [Y] OV
<i>addc</i> a, M	Add data in memory with ACC and carry bit, then put result into ACC Example: <i>addc</i> a, MEM ; Result: a ← a + MEM + C Affected flags: [Y] Z [Y] C [Y] AC [Y] OV
<i>addc</i> M, a	Add data in memory with ACC and carry bit, then put result into memory Example: <i>addc</i> MEM, a ; Result: MEM ← a + MEM + C Affected flags: [Y] Z [Y] C [Y] AC [Y] OV

<i>addc</i> a	Add carry with ACC, then put result into ACC Example: <i>addc</i> a ; Result: $a \leftarrow a + C$ Affected flags: [Y] Z [Y] C [Y] AC [Y] OV
<i>addc</i> M	Add carry with memory, then put result into memory Example: <i>addc</i> MEM ; Result: $MEM \leftarrow MEM + C$ Affected flags: [Y] Z [Y] C [Y] AC [Y] OV
<i>nadd</i> a, M	Add negative logic (2's complement) of ACC with memory Example: <i>nadd</i> a, MEM ; Result: $a \leftarrow \bar{a} + MEM$ Affected flags: [Y] Z [Y] C [Y] AC [Y] OV
<i>nadd</i> M, a	Add negative logic (2's complement) of memory with ACC Example: <i>nadd</i> MEM, a ; Result: $MEM \leftarrow \bar{MEM} + a$ Affected flags: [Y] Z [Y] C [Y] AC [Y] OV
<i>sub</i> a, l	Subtraction immediate data from ACC, then put result into ACC. Example: <i>sub</i> a, 0x0f; Result: $a \leftarrow a - 0fh$ ($a + [2's \text{ complement of } 0fh]$) Affected flags: [Y] Z [Y] C [Y] AC [Y] OV
<i>sub</i> a, M	Subtraction data in memory from ACC, then put result into ACC Example: <i>sub</i> a, MEM ; Result: $a \leftarrow a - MEM$ ($a + [2's \text{ complement of } M]$) Affected flags: [Y] Z [Y] C [Y] AC [Y] OV
<i>sub</i> M, a	Subtraction data in ACC from memory, then put result into memory Example: <i>sub</i> MEM, a ; Result: $MEM \leftarrow MEM - a$ ($MEM + [2's \text{ complement of } a]$) Affected flags: [Y] Z [Y] C [Y] AC [Y] OV
<i>subc</i> a, M	Subtraction data in memory and carry from ACC, then put result into ACC Example: <i>subc</i> a, MEM ; Result: $a \leftarrow a - MEM - C$ Affected flags: [Y] Z [Y] C [Y] AC [Y] OV
<i>subc</i> M, a	Subtraction ACC and carry bit from memory, then put result into memory Example: <i>subc</i> MEM, a ; Result: $MEM \leftarrow MEM - a - C$ Affected flags: [Y] Z [Y] C [Y] AC [Y] OV
<i>subc</i> a	Subtraction carry from ACC, then put result into ACC Example: <i>subc</i> a ; Result: $a \leftarrow a - C$ Affected flags: [Y] Z [Y] C [Y] AC [Y] OV
<i>subc</i> M	Subtraction carry from the content of memory, then put result into memory Example: <i>subc</i> MEM ; Result: $MEM \leftarrow MEM - C$ Affected flags: [Y] Z [Y] C [Y] AC [Y] OV
<i>inc</i> M	Increment the content of memory

	<p>Example: <i>inc</i> MEM ; Result: MEM ← MEM + 1 Affected flags: 『Y』 Z 『Y』 C 『Y』 AC 『Y』 OV</p>
<i>dec</i> M	<p>Decrement the content of memory Example: <i>dec</i> MEM; Result: MEM ← MEM - 1 Affected flags: 『Y』 Z 『Y』 C 『Y』 AC 『Y』 OV</p>
<i>clear</i> M	<p>Clear the content of memory Example: <i>clear</i> MEM ; Result: MEM ← 0 Affected flags: 『N』 Z 『N』 C 『N』 AC 『N』 OV</p>
<i>mul</i>	<p>Multiplication operation, 8x8 unsigned multiplications will be executed. Example: <i>mul</i> ; Result: {MulRH,ACC} ← ACC * MulOp Affected flags: 『N』 Z 『N』 C 『N』 AC 『N』 OV Application Example :</p> <p>-----</p> <pre> ... mov a, 0x5a ; mov mulop, a ; mov a, 0xa5 ; mul // 0x5A * 0xA5 = 3A02 (mulrh + ACC) mov ram0, a ; // LSB, ram0=0x02 mov a, mulrh ; // MSB, ACC=0X3A ... </pre> <p>-----</p>

7.3. Shift Operation Instructions

<i>sr</i> a	<p>Shift right of ACC, shift 0 to bit 7 Example: <i>sr</i> a ; Result: a (0,b7,b6,b5,b4,b3,b2,b1) ← a (b7,b6,b5,b4,b3,b2,b1,b0), C ← a(b0) Affected flags: 『N』 Z 『Y』 C 『N』 AC 『N』 OV</p>
<i>src</i> a	<p>Shift right of ACC with carry bit 7 to flag Example: <i>src</i> a ; Result: a (c,b7,b6,b5,b4,b3,b2,b1) ← a (b7,b6,b5,b4,b3,b2,b1,b0), C ← a(b0) Affected flags: 『N』 Z 『Y』 C 『N』 AC 『N』 OV</p>
<i>sr</i> M	<p>Shift right the content of memory, shift 0 to bit 7 Example: <i>sr</i> MEM ; Result: MEM(0,b7,b6,b5,b4,b3,b2,b1) ← MEM(b7,b6,b5,b4,b3,b2,b1,b0), C ← MEM(b0) Affected flags: 『N』 Z 『Y』 C 『N』 AC 『N』 OV</p>
<i>src</i> M	<p>Shift right of memory with carry bit 7 to flag Example: <i>src</i> MEM ; Result: MEM(c,b7,b6,b5,b4,b3,b2,b1) ← MEM (b7,b6,b5,b4,b3,b2,b1,b0), C ← MEM(b0) Affected flags: 『N』 Z 『Y』 C 『N』 AC 『N』 OV</p>

<i>sl a</i>	Shift left of ACC shift 0 to bit 0 Example: <i>sl a</i> ; Result: $a (b6,b5,b4,b3,b2,b1,b0,0) \leftarrow a (b7,b6,b5,b4,b3,b2,b1,b0)$, $C \leftarrow a (b7)$ Affected flags: [N] Z [Y] C [N] AC [N] OV
<i>slc a</i>	Shift left of ACC with carry bit 0 to flag Example: <i>slc a</i> ; Result: $a (b6,b5,b4,b3,b2,b1,b0,c) \leftarrow a (b7,b6,b5,b4,b3,b2,b1,b0)$, $C \leftarrow a(b7)$ Affected flags: [N] Z [Y] C [N] AC [N] OV
<i>sl M</i>	Shift left of memory, shift 0 to bit 0 Example: <i>sl MEM</i> ; Result: $MEM (b6,b5,b4,b3,b2,b1,b0,0) \leftarrow MEM (b7,b6,b5,b4,b3,b2,b1,b0)$, $C \leftarrow MEM(b7)$ Affected flags: [N] Z [Y] C [N] AC [N] OV
<i>slc M</i>	Shift left of memory with carry bit 0 to flag Example: <i>slc MEM</i> ; Result: $MEM (b6,b5,b4,b3,b2,b1,b0,C) \leftarrow MEM (b7,b6,b5,b4,b3,b2,b1,b0)$, $C \leftarrow MEM (b7)$ Affected flags: [N] Z [Y] C [N] AC [N] OV
<i>swap a</i>	Swap the high nibble and low nibble of ACC Example: <i>swap a</i> ; Result: $a (b3,b2,b1,b0,b7,b6,b5,b4) \leftarrow a (b7,b6,b5,b4,b3,b2,b1,b0)$ Affected flags: [N] Z [N] C [N] AC [N] OV

7.4. Logic Operation Instructions

<i>and a, l</i>	Perform logic AND on ACC and immediate data, then put result into ACC Example: <i>and a, 0x0f</i> ; Result: $a \leftarrow a \& 0fh$ Affected flags: [Y] Z [N] C [N] AC [N] OV
<i>and a, M</i>	Perform logic AND on ACC and memory, then put result into ACC Example: <i>and a, RAM10</i> ; Result: $a \leftarrow a \& RAM10$ Affected flags: [Y] Z [N] C [N] AC [N] OV
<i>and M, a</i>	Perform logic AND on ACC and memory, then put result into memory Example: <i>and MEM, a</i> ; Result: $MEM \leftarrow a \& MEM$ Affected flags: [Y] Z [N] C [N] AC [N] OV
<i>or a, l</i>	Perform logic OR on ACC and immediate data, then put result into ACC Example: <i>or a, 0x0f</i> ; Result: $a \leftarrow a 0fh$ Affected flags: [Y] Z [N] C [N] AC [N] OV
<i>or a, M</i>	Perform logic OR on ACC and memory, then put result into ACC Example: <i>or a, MEM</i> ; Result: $a \leftarrow a MEM$ Affected flags: [Y] Z [N] C [N] AC [N] OV
<i>or M, a</i>	Perform logic OR on ACC and memory, then put result into memory Example: <i>or MEM, a</i> ; Result: $MEM \leftarrow a MEM$ Affected flags: [Y] Z [N] C [N] AC [N] OV

<code>xor a, I</code>	<p>Perform logic XOR on ACC and immediate data, then put result into ACC</p> <p>Example: <code>xor a, 0x0f ;</code> Result: $a \leftarrow a \wedge 0fh$ Affected flags: [Y] Z [N] C [N] AC [N] OV</p>
<code>xor a, M</code>	<p>Perform logic XOR on ACC and memory, then put result into ACC</p> <p>Example: <code>xor a, MEM ;</code> Result: $a \leftarrow a \wedge RAM10$ Affected flags: [Y] Z [N] C [N] AC [N] OV</p>
<code>xor M, a</code>	<p>Perform logic XOR on ACC and memory, then put result into memory</p> <p>Example: <code>xor MEM, a ;</code> Result: $MEM \leftarrow a \wedge MEM$ Affected flags: [Y] Z [N] C [N] AC [N] OV</p>
<code>not a</code>	<p>Perform 1's complement (logical complement) of ACC</p> <p>Example: <code>not a ;</code> Result: $a \leftarrow \sim a$ Affected flags: [Y] Z [N] C [N] AC [N] OV Application Example:</p> <hr/> <pre> mov a, 0x38 ; // ACC=0X38 not a ; // ACC=0XC7 </pre> <hr/>
<code>not M</code>	<p>Perform 1's complement (logical complement) of memory</p> <p>Example: <code>not MEM ;</code> Result: $MEM \leftarrow \sim MEM$ Affected flags: [Y] Z [N] C [N] AC [N] OV Application Example:</p> <hr/> <pre> mov a, 0x38 ; mov mem, a ; // mem = 0x38 not mem ; // mem = 0xC7 </pre> <hr/>
<code>neg a</code>	<p>Perform 2's complement of ACC</p> <p>Example: <code>neg a ;</code> Result: $a \leftarrow \bar{a}$ Affected flags: [Y] Z [N] C [N] AC [N] OV Application Example:</p> <hr/> <pre> mov a, 0x38 ; // ACC=0X38 neg a ; // ACC=0XC8 </pre> <hr/>

<i>neg</i> M	<p>Perform 2's complement of memory Example: <i>neg</i> MEM; Result: MEM ← $\bar{\text{MEM}}$ Affected flags: [Y] Z [N] C [N] AC [N] OV</p> <p>Application Example:</p> <hr/> <pre> mov a, 0x38 ; mov mem, a ; // mem = 0x38 not mem ; // mem = 0xC8 </pre> <hr/>
<i>comp</i> a, M	<p>Compare ACC with the content of memory Example: <i>comp</i> a, MEM; Result: Flag will be changed by regarding as (a - MEM) Affected flags: [Y] Z [Y] C [Y] AC [Y] OV</p> <p>Application Example:</p> <hr/> <pre> mov a, 0x38 ; mov mem, a ; comp a, mem ; // Z flag is set as 1 mov a, 0x42 ; mov mem, a ; mov a, 0x38 ; comp a, mem ; // C flag is set as 1 </pre> <hr/>
<i>comp</i> M, a	<p>Compare ACC with the content of memory Example: <i>comp</i> MEM, a; Result: Flag will be changed by regarding as (MEM - a) Affected flags: [Y] Z [Y] C [Y] AC [Y] OV</p>

7.5. Bit Operation Instructions

<i>set0</i> IO.n	<p>Set bit n of IO port to low Example: <i>set0</i> pa.5 ; Result: set bit 5 of port A to low Affected flags: [N] Z [N] C [N] AC [N] OV</p>
<i>set1</i> IO.n	<p>Set bit n of IO port to high Example: <i>set1</i> pb.5 ; Result: set bit 5 of port B to high Affected flags: [N] Z [N] C [N] AC [N] OV</p>
<i>swapc</i> IO.n	<p>Swap the nth bit of IO port with carry bit Example: <i>swapc</i> IO.0; Result: C ← IO.0 , IO.0 ← C</p> <p>When IO.0 is a port to output pin, carry C will be sent to IO.0; When IO.0 is a port from input pin, IO.0 will be sent to carry C;</p>

	<p>Affected flags: [N] Z [Y] C [N] AC [N] OV</p> <p>Application Example1 (serial output) :</p> <pre> ... set1 pac.0 ; // set PA.0 as output ... set0 flag.1 ; // C=0 swopc pa.0 ; // move C to PA.0 (bit operation), PA.0=0 set1 flag.1 ; // C=1 swopc pa.0 ; // move C to PA.0 (bit operation), PA.0=1 ... </pre> <p>Application Example2 (serial input) :</p> <pre> ... set0 pac.0 ; // set PA.0 as input ... swopc pa.0 ; // read PA.0 to C (bit operation) src a ; // shift C to bit 7 of ACC swopc pa.0 ; // read PA.0 to C (bit operation) src a ; // shift new C to bit 7, old C ... </pre>
<i>set0</i> M.n	<p>Set bit n of memory to low</p> <p>Example: <i>set0</i> MEM.5 ;</p> <p>Result: set bit 5 of MEM to low</p> <p>Affected flags: [N] Z [N] C [N] AC [N] OV</p>
<i>set1</i> M.n	<p>Set bit n of memory to high</p> <p>Example: <i>set1</i> MEM.5 ;</p> <p>Result: set bit 5 of MEM to high</p> <p>Affected flags: [N] Z [N] C [N] AC [N] OV</p>

7.6. Conditional Operation Instructions

<i>ceqsn</i> a, l	<p>Compare ACC with immediate data and skip next instruction if both are equal. Flag will be changed like as ($a \leftarrow a - l$)</p> <p>Example: <i>ceqsn</i> a, 0x55 ; <i>inc</i> MEM ; <i>goto</i> error ;</p> <p>Result: If $a=0x55$, then “goto error”; otherwise, “inc MEM”.</p> <p>Affected flags: [Y] Z [Y] C [Y] AC [Y] OV</p>
-------------------	---

<i>ceqsn</i> a, M	<p>Compare ACC with memory and skip next instruction if both are equal. Flag will be changed like as $(a \leftarrow a - M)$ Example: <i>ceqsn</i> a, MEM; Result: If a=MEM, skip next instruction Affected flags: [Y] Z [Y] C [Y] AC [Y] OV</p>
<i>cneqsn</i> a, M	<p>Compare ACC with memory and skip next instruction if both are not equal. Flag will be changed like as $(a \leftarrow a - M)$ Example: <i>cneqsn</i> a, MEM; Result: If a≠MEM, skip next instruction Affected flags: [Y] Z [Y] C [Y] AC [Y] OV</p>
<i>cneqsn</i> a, I	<p>Compare ACC with immediate data and skip next instruction if both are no equal. Flag will be changed like as $(a \leftarrow a - I)$ Example: <i>cneqsn</i> a, 0x55 ; <i>inc</i> MEM ; <i>goto</i> error ; Result: If a≠0x55, then “goto error”; Otherwise, “inc MEM”. Affected flags: [Y] Z [Y] C [Y] AC [Y] OV</p>
<i>t0sn</i> IO.n	<p>Check IO bit and skip next instruction if it's low Example: <i>t0sn</i> pa.5; Result: If bit 5 of port A is low, skip next instruction Affected flags: [N] Z [N] C [N] AC [N] OV</p>
<i>t1sn</i> IO.n	<p>Check IO bit and skip next instruction if it's high Example: <i>t1sn</i> pa.5 ; Result: If bit 5 of port A is high, skip next instruction Affected flags: [N] Z [N] C [N] AC [N] OV</p>
<i>t0sn</i> M.n	<p>Check memory bit and skip next instruction if it's low Example: <i>t0sn</i> MEM.5 ; Result: If bit 5 of MEM is low, then skip next instruction Affected flags: [N] Z [N] C [N] AC [N] OV</p>
<i>t1sn</i> M.n	<p>Check memory bit and skip next instruction if it's high EX: <i>t1sn</i> MEM.5 ; Result: If bit 5 of MEM is high, then skip next instruction Affected flags: [N] Z [N] C [N] AC [N] OV</p>
<i>izsn</i> a	<p>Increment ACC and skip next instruction if ACC is zero Example: <i>izsn</i> a ; Result: $a \leftarrow a + 1$, skip next instruction if a = 0 Affected flags: [Y] Z [Y] C [Y] AC [Y] OV</p>
<i>dzsn</i> a	<p>Decrement ACC and skip next instruction if ACC is zero Example: <i>dzsn</i> a ; Result: $A \leftarrow A - 1$, skip next instruction if a = 0 Affected flags: [Y] Z [Y] C [Y] AC [Y] OV</p>

<i>izsn</i> M	<p>Increment memory and skip next instruction if memory is zero</p> <p>Example: <i>izsn</i> MEM;</p> <p>Result: MEM \leftarrow MEM + 1, skip next instruction if MEM= 0</p> <p>Affected flags: [Y] Z [Y] C [Y] AC [Y] OV</p>
<i>dzsn</i> M	<p>Decrement memory and skip next instruction if memory is zero</p> <p>Example: <i>dzsn</i> MEM;</p> <p>Result: MEM \leftarrow MEM - 1, skip next instruction if MEM = 0</p> <p>Affected flags: [Y] Z [Y] C [Y] AC [Y] OV</p>

7.7. System control Instructions

<i>call</i> label	<p>Function call, address can be full range address space</p> <p>Example: <i>call</i> function1;</p> <p>Result: [sp] \leftarrow pc + 1 pc \leftarrow function1 sp \leftarrow sp + 2</p> <p>Affected flags: [N] Z [N] C [N] AC [N] OV</p>
<i>goto</i> label	<p>Go to specific address which can be full range address space</p> <p>Example: <i>goto</i> error;</p> <p>Result: Go to error and execute program.</p> <p>Affected flags: [N] Z [N] C [N] AC [N] OV</p>
<i>ret</i> I	<p>Place immediate data to ACC, then return</p> <p>Example: <i>ret</i> 0x55;</p> <p>Result: A \leftarrow 55h ret ;</p> <p>Affected flags: [N] Z [N] C [N] AC [N] OV</p>
<i>ret</i>	<p>Return to program which had function call</p> <p>Example: <i>ret</i>;</p> <p>Result: sp \leftarrow sp - 2 pc \leftarrow [sp]</p> <p>Affected flags: [N] Z [N] C [N] AC [N] OV</p>
<i>reti</i>	<p>Return to program that is interrupt service routine. After this command is executed, global interrupt is enabled automatically.</p> <p>Example: <i>reti</i>;</p> <p>Affected flags: [N] Z [N] C [N] AC [N] OV</p>
<i>nop</i>	<p>No operation</p> <p>Example: <i>nop</i>;</p> <p>Result: nothing changed</p> <p>Affected flags: [N] Z [N] C [N] AC [N] OV</p>
<i>pcadd</i> a	<p>Next program counter is current program counter plus ACC.</p> <p>Example: <i>pcadd</i> a;</p> <p>Result: pc \leftarrow pc + a</p> <p>Affected flags: [N] Z [N] C [N] AC [N] OV</p>

	<p>Application Example:</p> <pre> mov a, 0x02 ; pcadd a ; // PC <- PC+2 goto err1 ; goto correct ; // jump here goto err2 ; goto err3 ; ... correct: // jump here </pre>
<i>engint</i>	<p>Enable global interrupt enable Example: <i>engint</i>; Result: Interrupt request can be sent to CPU Affected flags: [N] Z [N] C [N] AC [N] OV</p>
<i>disgint</i>	<p>Disable global interrupt enable Example: <i>disgint</i>; Result: Interrupt request is blocked from CPU Affected flags: [N] Z [N] C [N] AC [N] OV</p>
<i>stopsys</i>	<p>System halt. Example: <i>stopsys</i>; Result: Stop the system clocks and halt the system Affected flags: [N] Z [N] C [N] AC [N] OV</p>
<i>stopexe</i>	<p>CPU halt. The oscillator module is still active to output clock, however, system clock is disabled to save power. Example: <i>stopexe</i>; Result: Stop the system clocks and keep oscillator modules active. Affected flags: [N] Z [N] C [N] AC [N] OV</p>
<i>reset</i>	<p>Reset the whole chip, its operation will be same as hardware reset. Example: <i>reset</i>; Result: Reset the whole chip. Affected flags: [N] Z [N] C [N] AC [N] OV</p>
<i>wdreset</i>	<p>Reset Watchdog timer. Example: <i>wdreset</i>; Result: Reset Watchdog timer. Affected flags: [N] Z [N] C [N] AC [N] OV</p>

7.8. Summary of Instructions Execution Cycle

2T		<i>goto, call, pcadd, ret, reti, idxm</i>
2T	Condition is fulfilled.	<i>ceqsn, cneqsn, t0sn, t1sn, dzsn, izsn</i>
1T	Condition is not fulfilled.	
1T		Others

7.9. Summary of affected flags by Instructions

Instruction	Z	C	AC	OV	Instruction	Z	C	AC	OV	Instruction	Z	C	AC	OV
<i>mov a, l</i>	-	-	-	-	<i>mov M, a</i>	-	-	-	-	<i>mov a, M</i>	Y	-	-	-
<i>mov a, IO</i>	Y	-	-	-	<i>mov IO, a</i>	-	-	-	-	<i>ldt16 word</i>	-	-	-	-
<i>stt16 word</i>	-	-	-	-	<i>idxm a, index</i>	-	-	-	-	<i>idxm index, a</i>	-	-	-	-
<i>xch M</i>	-	-	-	-	<i>pushaf</i>	-	-	-	-	<i>popaf</i>	Y	Y	Y	Y
<i>add a, l</i>	Y	Y	Y	Y	<i>add a, M</i>	Y	Y	Y	Y	<i>add M, a</i>	Y	Y	Y	Y
<i>addc a, M</i>	Y	Y	Y	Y	<i>addc M, a</i>	Y	Y	Y	Y	<i>addc a</i>	Y	Y	Y	Y
<i>addc M</i>	Y	Y	Y	Y	<i>nadd a, M</i>	Y	Y	Y	Y	<i>nadd M, a</i>	Y	Y	Y	Y
<i>sub a, l</i>	Y	Y	Y	Y	<i>sub a, M</i>	Y	Y	Y	Y	<i>sub M, a</i>	Y	Y	Y	Y
<i>subc a, M</i>	Y	Y	Y	Y	<i>subc M, a</i>	Y	Y	Y	Y	<i>subc a</i>	Y	Y	Y	Y
<i>subc M</i>	Y	Y	Y	Y	<i>inc M</i>	Y	Y	Y	Y	<i>dec M</i>	Y	Y	Y	Y
<i>clear M</i>	-	-	-	-	<i>mul</i>	-	-	-	-	<i>sr a</i>	-	Y	-	-
<i>src a</i>	-	Y	-	-	<i>sr M</i>	-	Y	-	-	<i>src M</i>	-	Y	-	-
<i>sl a</i>	-	Y	-	-	<i>slc a</i>	-	Y	-	-	<i>sl M</i>	-	Y	-	-
<i>slc M</i>	-	Y	-	-	<i>swap a</i>	-	-	-	-	<i>and a, l</i>	Y	-	-	-
<i>and a, M</i>	Y	-	-	-	<i>and M, a</i>	Y	-	-	-	<i>or a, l</i>	Y	-	-	-
<i>or a, M</i>	Y	-	-	-	<i>or M, a</i>	Y	-	-	-	<i>xor a, l</i>	Y	-	-	-
<i>wdreset</i>	-	-	-	-	<i>xor a, M</i>	Y	-	-	-	<i>xor M, a</i>	Y	-	-	-
<i>not a</i>	Y	-	-	-	<i>not M</i>	Y	-	-	-	<i>neg a</i>	Y	-	-	-
<i>neg M</i>	Y	-	-	-	<i>comp a, M</i>	Y	Y	Y	Y	<i>comp M, a</i>	Y	Y	Y	Y
<i>set0 IO.n</i>	-	-	-	-	<i>set1 IO.n</i>	-	-	-	-	<i>set0 M.n</i>	-	-	-	-
<i>set1 M.n</i>	-	-	-	-	<i>swapc IO.n</i>		Y			<i>ceqsn a, l</i>	Y	Y	Y	Y
<i>ceqsn a, M</i>	Y	Y	Y	Y	<i>cneqsn a, M</i>	Y	Y	Y	Y	<i>cneqsn a, l</i>	Y	Y	Y	Y
<i>t0sn IO.n</i>	-	-	-	-	<i>t1sn IO.n</i>	-	-	-	-	<i>t0sn M.n</i>	-	-	-	-
<i>t1sn M.n</i>	-	-	-	-	<i>izsn a</i>	Y	Y	Y	Y	<i>dzsn a</i>	Y	Y	Y	Y
<i>izsn M</i>	Y	Y	Y	Y	<i>dzsn M</i>	Y	Y	Y	Y	<i>call label</i>	-	-	-	-
<i>goto label</i>	-	-	-	-	<i>ret l</i>	-	-	-		<i>ret</i>	-	-	-	-
<i>reti</i>	-	-	-	-	<i>nop</i>	-	-	-	-	<i>pcadd a</i>	-	-	-	-
<i>engint</i>	-	-	-	-	<i>disgint</i>	-	-	-	-	<i>stopsys</i>	-	-	-	-
<i>stopexe</i>	-	-	-	-	<i>reset</i>	-	-	-						

7.10. RAM definition

Bit access of RAM is only available for address from 0x00 to 0x3F.

8. Code Options

Option	Selection	Description
Security	Enable	OTP content is protected and program cannot be read back
	Disable	OTP content is not protected so program can be read back
LVR	4.1V	Select LVR = 4.1V
	3.6V	Select LVR = 3.6V
	3.1V	Select LVR = 3.1V
	2.8V	Select LVR = 2.8V
	2.5V	Select LVR = 2.5V
	2.2V	Select LVR = 2.2V
	2.0V	Select LVR = 2.0V
	1.8V	Select LVR = 1.8V
Under_20mS_VDD_OK	Yes	reach normal operating voltage quickly within 20 mS
	No	can't reach normal operating voltage quickly within 20 mS
Interrupt Src0	PA.0	INTEN/ INTRQ.Bit0 is from PA.0
	PB.5	INTEN/ INTRQ.Bit0 is from PB.5
Interrupt Src1	PB.0	INTEN/ INTRQ.Bit1 is from PB.0
	PA.4	INTEN/ INTRQ.Bit1 is from PA.4

9. Special Notes

This chapter is to remind user who use PMC131/PMS131/PMS130 series IC in order to avoid frequent errors upon operation.

9.1. Warning

User must read all application notes of the IC by detail before using it. Please download the related application notes from the following link:

<http://www.padauk.com.tw/tw/technical/index.aspx>

9.2. Using IC

9.2.1. IO pin usage and setting

- (1) IO pin is set to be digital input
 - ◆ When IO is set as digital input, the level of V_{ih} and V_{il} would changes with the voltage and temperature. Please follow the minimum value of V_{ih} and the maximum value of V_{il} .
 - ◆ The value of internal pull high resistor would also changes with the voltage, temperature and pin voltage. It is not the fixed value.
- (2) IO pin as digital input and enable wakeup function
 - ◆ Configure IO pin as input.
 - ◆ Set PADIER and PBDIER registers to set the corresponding bit to 1.
- (3) PA5 is set to be output pin
 - ◆ PA5 can be set to be Open-Drain output pin only, output high requires adding pull-up resistor.
- (4) PA5 is set to be PRSTB input pin
 - ◆ No internal pull-up resistor for PA5
 - ◆ Configure PA5 as input
 - ◆ Set CLKMD.0=1 to enable PA5 as PRSTB input pin
- (5) PA5 is set to be input pin and to connect with a push button or a switch by a long wire
 - ◆ Needs to put a $>10\Omega$ resistor in between PA5 and the long wire
 - ◆ **Avoid using PA5 as input in such application.**
- (6) PA7 and PA6 as external crystal oscillator
 - ◆ Configure PA7 and PA6 as input
 - ◆ Disable PA7 and PA6 internal pull-up resistor
 - ◆ Configure PADIER register to set PA6 and PA7 as analog input
 - ◆ EOSCR register bit [6:5] selects corresponding crystal oscillator frequency :
 - ◇ 01 : for lower frequency, ex : 32kHz
 - ◇ 10 : for middle frequency, ex : 455kHz, 1MHz
 - ◇ 11 : for higher frequency, ex : 4MHz
 - ◆ Program EOSCR.7 =1 to enable crystal oscillator
 - ◆ Ensure EOSC working well before switching from IHRC or ILRC to EOSC

Note: Please read the PMC-APN013 carefully. According to PMC-APN013,, the crystal oscillator should be used reasonably. If the following situations happen to cause IC start-up slowly or non-startup, PADAUK Technology is not responsible for this: the quality of the user's crystal oscillator is not good, the usage conditions are unreasonable, the PCB cleaner leakage current, or the PCB layouts are unreasonable.

(7) If PB1 is set as input to detect the zero-crossing point of AC power, please put at least 1M Ω in series.

(8) Using the PB3:

When PB3 is used as digital input and any other pin of Port B is used as output pin, please do **NOT** issue set1/set0 commands to control the output pin level. The correct way is to write the Port B register to control the output pin level, or use PB3 as output pin only.

Example: Using PB3 as digital input pin, and PB7 as output pin.

```
pbc    = 0b_1111_0111;
pb     = 0b_0000_0000;
pbph   = 0b_1000_1000; // PB3 is set to have internal pull high
$ pbdier 0b_1111_1111;
```

Please do **NOT** use set1/set0 to set PB7 output pin level

```
if ( pb.3 )
{
    set1    pb.7 ;    // Don't use pb.7 = 1, either!
}
else
{
    set0    pb.7 ;    // Don't use pb.7 = 0, either!
}
```

The correct way is to write the Port B register to control PB7 output pin level

```
if ( pb.3 )
{
    pb = 0b_1000_0000;    // bit 3 must be 0
}
else
{
    pb = 0b_0000_0000;    // bit 3 must be 0
}
```

9.2.2. Interrupt

- (1) When using the interrupt function, the procedure should be:

Step1: Set INTEN register, enable the interrupt control bit

Step2: Clear INTRQ register

Step3: In the main program, using ENGINT to enable CPU interrupt function

Step4: Wait for interrupt. When interrupt occurs, enter to Interrupt Service Routine

Step5: After the Interrupt Service Routine being executed, return to the main program

* Use DISGINT in the main program to disable all interrupts

* When interrupt service routine starts, use PUSHAF instruction to save ALU and FLAG register. POPAF instruction is to restore ALU and FLAG register before RETI as below:

```
void Interrupt (void) // Once the interrupt occurs, jump to interrupt service routine
{
    // enter DISGINT status automatically, no more interrupt is accepted
    PUSHAF;
    ...
    POPAF;
} // RETI will be added automatically. After RETI being executed, ENGINT status
will be restored
```

- (2) INTEN and INTRQ have no initial values. Please set required value before enabling interrupt function

- (3) PA4 and PB5 can be used as external interrupt pins. When using the PA4 as external interrupt pin, the setting method of **inten/intrq/integs** registers are same as that of PB0, the only difference is to choose PB0 or PA4 as source of interrupt_Src1 in PADAUK_CODE_OPTION. Similarly, when using the PB5 as external interrupt pin, the setting method of **inten/intrq/integs** registers are same as that of PA0, the only difference is to choose PA0 or PB5 as source of interrupt_Src0 in PADAUK_CODE_OPTION.

9.2.3. System clock switching

- (1) System clock can be switched by CLKMD register. Please notice that, **NEVER switch the system clock and turn off the original clock source at the same time**. For example: When switching from clock A to clock B, please switch to clock B first; and after that turn off the clock A oscillator through CLKMD.

- ◆ Case 1 : Switch system clock from ILRC to IHRC/2

```
CLKMD = 0x36; // switch to IHRC, ILRC can not be disabled here
```

```
CLKMD.2 = 0; // ILRC can be disabled at this time
```

- ◆ Case 2 : Switch system clock from ILRC to EOSC

```
CLKMD = 0xA6; // switch to EOSC, ILRC can not be disabled here
```

```
CLKMD.2 = 0; // ILRC can be disabled at this time
```

- ◆ **ERROR.** Switch ILRC to IHRC and turn off ILRC simultaneously

```
CLKMD = 0x50; // MCU will hang
```

- (2) Please ensure the EOSC oscillation has established before switching from ILRC or IHRC to EOSC. MCU will not check its status. Please wait for a while after enabling EOSC. System clock can be switched to

EOSC afterwards. Otherwise, MCU will hang. The example for switching system clock from ILRC to 4MHz EOSC after boot up is as below:

```
.ADJUST_IC    DISABLE
CLKMD.1 = 0;           // turn off WDT for executing delay instruction.
$ EOSCR    Enable, 4MHz; // 4MHz EOSC start to oscillate.
// delay time to wait crystal oscillator stable
$ T16M EOSC, /1, BIT10
Word Count = 0;
Stt16 Count;
Intrq.T16 = 0;
do
{ nop; }while(!Intrq.T16);
CLKMD    = 0xA4;       // ILRC -> EOSC;
CLKMD.2 = 0;          // turn off ILRC only if necessary
```

The delay duration should be adjusted in accordance with the characteristic of the crystal and PCB. To measure the oscillator signal by the oscilloscope, please select (x10) on the probe and measure through PA6(X2) pin to avoid the interference on the oscillator

9.2.4. Power down mode, wakeup and watchdog

- (1) Watchdog will be inactive once ILRC is disabled
- (2) Please turn off watchdog before executing STOPSYS or STOPEXE instruction, otherwise IC will be reset due to watchdog timeout. It is the same as in ICE emulation.
- (3) The clock source of Watchdog is ILRC if the fast wakeup is disabled; otherwise, the clock source of Watchdog will be the system clock and the reset time from watchdog becomes much shorter. It is recommended to disable Watchdog and enable fast wakeup before entering STOPSYS mode. When the system is waken up from power down mode, please firstly disable fast wakeup function, and then enable Watchdog. It is to avoid system to be reset after being waken up.
- (4) If enable Watchdog during programming and also wants the fast wakeup, the example as below:

```
CLKMD.En_WatchDog    =    0;           // disable watchdog timer
$ MISC    Fast_Wake_Up;
stopexe;
nop;
$ MISC    WT_xx;           // Reset Watchdog time to normal wake-up
Wdreset;
CLKMD.En_WatchDog    =    1;           // enable watchdog timer
```

9.2.5. TIMER16 time out

When select \$ INTEGS BIT_R (default value) and T16M counter BIT8 to generate interrupt, if T16M counts from 0, the first interrupt will occur when the counter reaches to 0x100 (BIT8 from 0 to 1) and the second interrupt will occur when the counter reaches 0x300 (BIT8 from 0 to 1). Therefore, selecting BIT8 as 1 to generate interrupt means that the interrupt occurs every 512 counts. Please notice that if T16M counter is restarted, the next interrupt will occur once Bit8 turns from 0 to 1.

If select \$ INTEGS BIT_F (BIT triggers from 1 to 0) and T16M counter BIT8 to generate interrupt, the T16M counter changes to an interrupt every 0x200/0x400/0x600/. Please pay attention to two differences with setting INTEGS methods.

9.2.6. IHRC

- (1) The IHRC frequency calibration is performed when IC is programmed by the writer.
- (2) Because the characteristic of the Epoxy Molding Compound (EMC) would some degrees affects the IHRC frequency (either for package or COB), if the calibration is done before molding process, the actual IHRC frequency after molding may be deviated or becomes out of spec. Normally, the frequency is getting slower a bit.
- (3) It usually happens in COB package or Quick Turnover Programming (QTP). And PADAUK would not take any responsibility for this situation.
- (4) Users can make some compensatory adjustments according to their own experiences. For example, users can set IHRC frequency to be 0.5% ~ 1% higher and aim to get better re-targeting after molding.

9.2.7. LVR

- (1) VDD must reach or above 2.0V for successful power-on process; otherwise IC will be inactive.
- (2) The setting of LVR (1.8V, 2.0V, 2.2V etc.) will be valid just after successful power-on process.
- (3) User can set MISC.2 as "1" to disable LVR. However, VDD must be kept as exceeding the lowest working voltage of chip; Otherwise IC may work abnormally.

9.2.8. Programming the PMC131/PMS131/PMS130

There are 6 pins for using the writer to program: PA3, PA4, PA5, PA6, V_{DD} , and GND.

Please use PDK3S-P-002 for program real chip and just use the CN38 jumper (at the back for the writer) with putting the S16/D16, S16A/D16A, S14/D14 IC downward three spaces on the Textool. S08/D08 or other packages could be programmed by connecting the signals correspondingly. All the signals of the left side of the jumpers are the same and as the descriptions at the left bottom corner. They are V_{DD} , PA0(not used), PA3, PA4, PA5, PA6, PA7(not used), and GND.

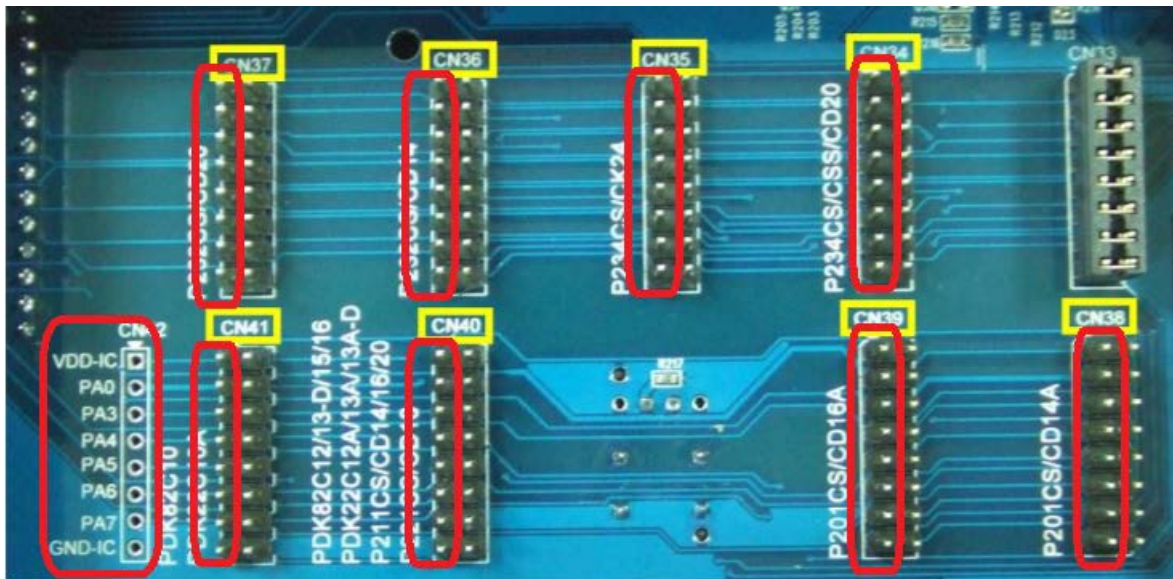

If user use PDK5S-P-003 or above to program, please follow the instruction.

- Special notes about voltage and current while Multi-Chip-Package(MCP) or On-Board Programming

- (1) PA5 (V_{PP}) may be higher than 11V.
- (2) V_{DD} may be higher than 7V, and its maximum current may reach about 20mA.
- (3) All other signal pins level (except GND) are the same as V_{DD} .

User should confirm when using this product in MCP or On-Board Programming, the peripheral circuit or components will not be destroyed or limit the above voltages.

9.3. Using ICE

- (1) PDK5S-I-S01/2(B) supports PMC131/PMS131/PMS130 MCU emulation, the following items should be noted when using PDK5S-I-S01/2(B):

- Fast Wakeup time is different from PDK5S-I-S01/2(B): 128 Sys Clk, PMC131/PMS131/PMS130: 45 ILRC.
- When using PB1 in ADCRGC, PA1 must float.