

DESCRIPTION

The EV28115DQ-01C is an evaluation board for the MP28115, a monolithic synchronous buck regulator.

The MP28115 delivers 4A continuous load current over an operating input voltage 2.7V to 6.0V. The output is adjustable over a range of 0.8V to 0.9xV_{IN} by means of an external resistor from FB pin to ground.

The current mode control used in MP28115 provides fast transient response and cycle-by-cycle current limiting. The EV board will go into hiccup mode to protect against over current/short circuit.

This EV board can be turned on or shut down via a remote ON/OFF input that is referenced to ground. This input is compatible with popular logic devices.

This EV board also has power good indicator. The output of POK is pulled to ground when output voltage is under or over 10% of its setting voltage.

ELECTRICAL SPECIFICATIONS

Parameter	Symbol	Value	Units
Input Voltage	V _{IN}	2.7 – 6.0	V
Output Voltage	V _{OUT}	1.8	V
Output Current	I _{OUT}	4	A

FEATURES

- 4A Output Current
- 2.7V to 6.0V Operating Input Range
- Built-in Soft Start
- Adjustable Output from 0.8V to 0.9xV_{IN}
- Fully Assembled and Tested

APPLICATIONS

- μ P/ASIC/DSP/FPGA Core and I/O Supplies
- Printers and LCD TVs
- Network and Telecom Equipment
- Point of Load Regulators

"MPS" and "The Future of Analog IC Technology" are Registered Trademarks of Monolithic Power Systems, Inc.

EV28115DQ-01C EVALUATION BOARD



(L x W x H) 2.4" x 2.0" x 0.5"
(6.1cm x 5.1cm x 1.4 cm)

Board Number	MPS IC Number
EV28115DQ-01C	MP28115DQ

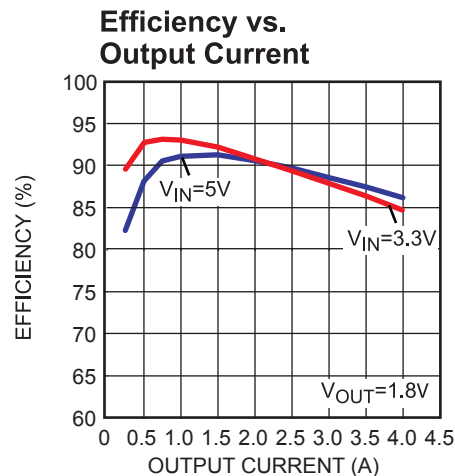

EVALUATION BOARD SCHEMATIC

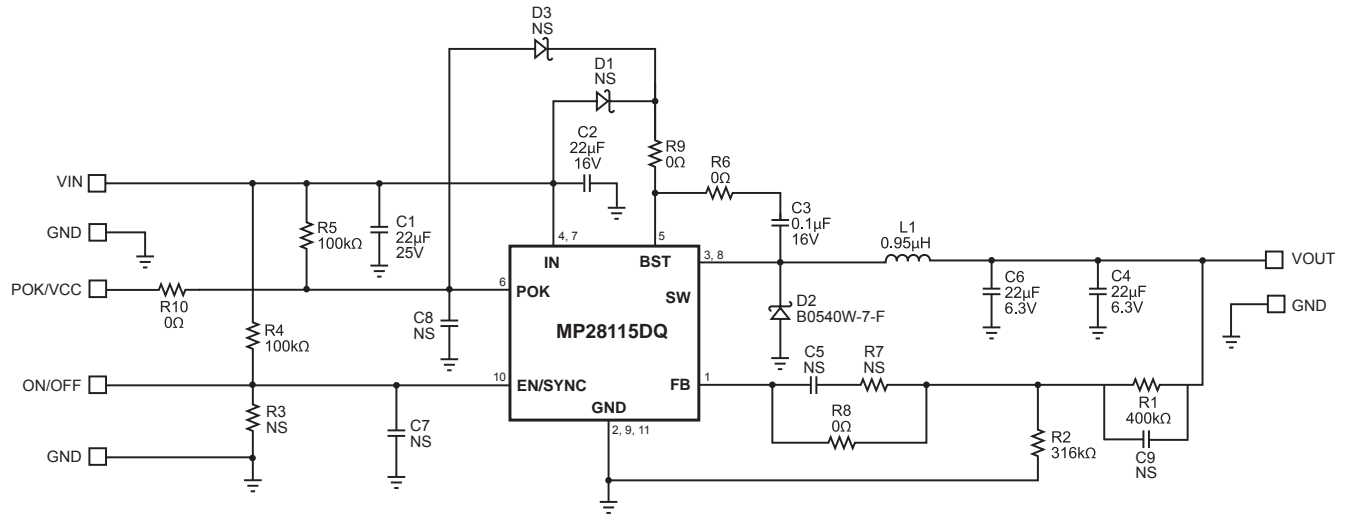

EV28115DQ-01C BILL OF MATERIALS

Qty	Ref	Value	Description	Package	Manufacturer	Manufacturer P/N
2	C1, C2	22μF	Ceramic Cap., 16V, X7R	SMC1210	Murata	GRM32ER71C226K
1	C3	0.1μF	Ceramic Cap., 16V, X7R	SMC0603	Murata	GRM188R71C104K
2	C4, C6	22μF	Ceramic Cap., 6.3V, X7R	SMC1210	Murata	GRM32ER70J226K
3	C5, C7, C8, C9	NS	Not Stuffed	SMC0603		
1	R1	400kΩ	Film Resistor, 1%	SMR0603	Yageo	RC0603FR-07400KL
1	R2	316kΩ	Film Resistor, 1%	SMR0603	Yageo	RC0603FR-07316KL
2	R4, R5	100kΩ	Film Resistor, 5%	SMR0603	Yageo	RC0603JR-07100KL
2	R3, R7	NS	Do Not Stuff	SMR0603		
4	R6, R8, R9, R10	0Ω	Film Resistor, 5%	SMR0603	Yageo	RC0603JR-0700R0L
2	D1, D3	NS	Not Stuffed	SOD-323		
1	D2	0.5A, 40V	Schottky Diode	SOD-123	Diodes Inc	B0540W-7-F
1	L1	0.95μH	Inductor, I _{SA} =13A, R _{DC} =6.4mΩ	SML 7x7x3mm	Würth Electronics	WE-744310095
1	U1		Step-Down Regulator	QFN10	Monolithic Power Systems Inc.	MP28115DQ

PRINTED CIRCUIT BOARD LAYOUT

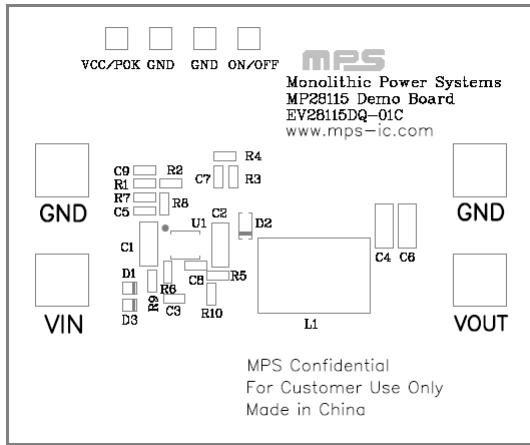

Figure 1—Top Silk Layer

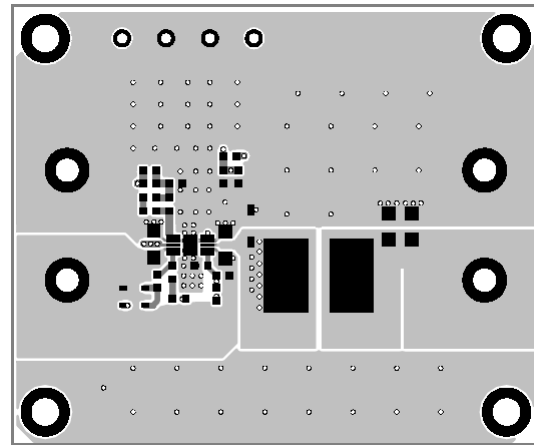

Figure 2—Top Layer

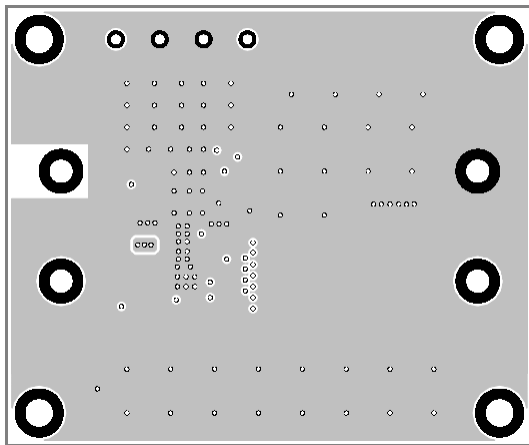

Figure 3—Inner Layer 1

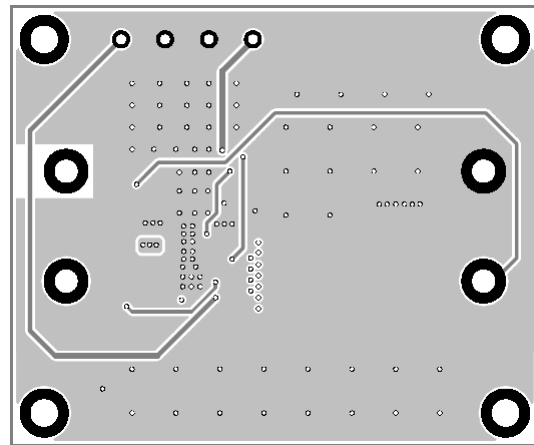

Figure 4—Inner Layer 2

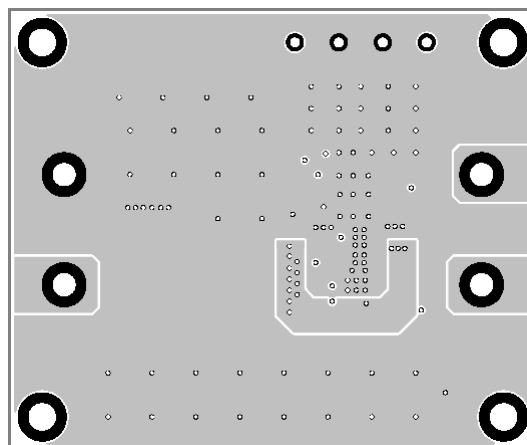

Figure 5—Bottom Layer

QUICK START GUIDE

1. Connect the positive and negative terminals of the load to the VOUT and GND pins, respectively.
2. Preset the power supply output to 2.7V-6.0V, then turn it off.
3. Connect the positive and negative terminals of the power supply output to the VIN and GND pins, respectively.
4. Turn the power supply on. The EV28115DQ board will automatically startup.
5. To use the Enable function, apply a digital input to the EN pin. Drive EN higher than 1.6V to turn on the regulator, drive EN less than 0.4V to turn it off.
6. Use R1 and R2 to set the output voltage with $V_{FB} = 0.8V$. Follow the Application Information section in the device datasheet to select the proper value of R1, R2, inductor and output capacitor values when output voltage is changed.

NOTICE: The information in this document is subject to change without notice. Users should warrant and guarantee that third party Intellectual Property rights are not infringed upon when integrating MPS products into any application. MPS will not assume any legal responsibility for any said applications.