

目錄 MAPX	設變內容 MODIFICATION	日期 DATE

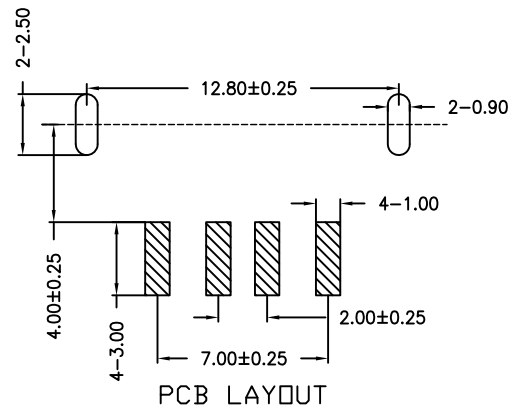
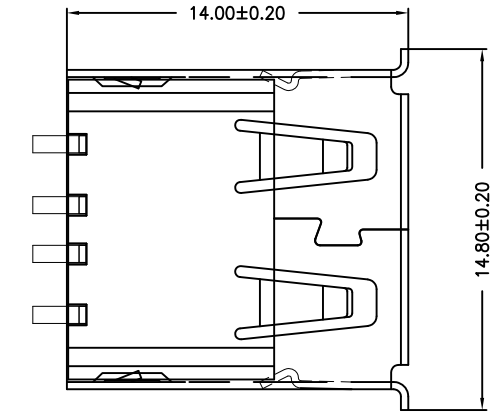
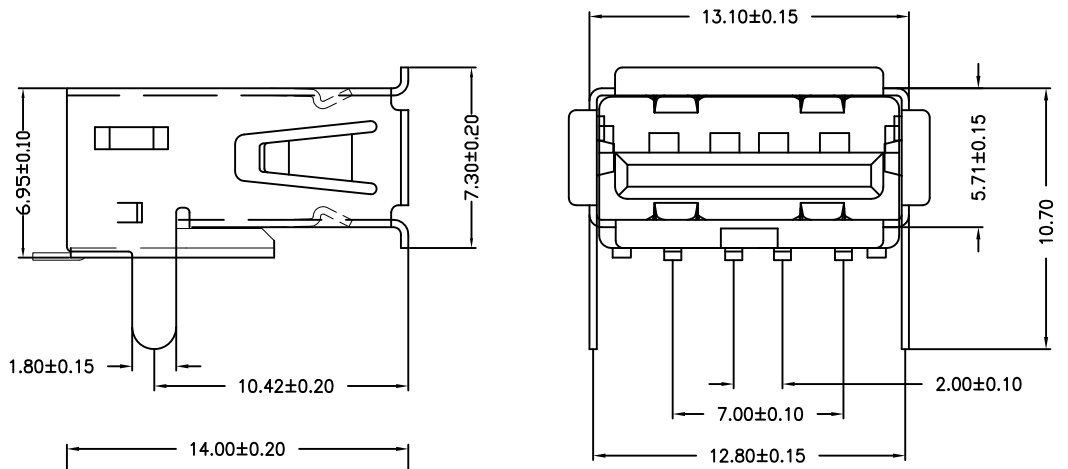

NOTE:

- Material:
 - Housing: Thermoplastics, UL94V-0 (ROHS, HF)
 - Contact: Phosphor Bronze C5191-EH/C2680-EH, T=0.25mm
 - Shell: COPPER ALLOY T=0.30mm
- FINISH:
 - Contact: 15u" Gold Plated on Contact Area, 80u" Min. Tin Plated on Solder Area, 50u" Min. Nickel Underplating Over All.
 - Shell: 50u" Min. Nickel Underplating Over All.
- Specification:
 - Rating:
 - Rated voltage 500V AC/DC. Rated current: 2 A Max.
 - Electrical:
 - Insulation Resistance (EIA-364-21): 1000MΩ Min. at 500V/DC for 1Minute.
 - Contact Resistance (EIA-364-23): 30 mΩ Max. at 20mV Max, 50mA
 - Dielectric Withstanding Voltage (EIA-364-20): No discharge, flashover or breakdown at 500V/AC 1Minute
- Plug extraction force shall be between 1.0kgf and 2.00kgf
- Contact finish:
 - 01: Selective Gold Flash
 - 02: Selective Gold 1U"
 - 03: Selective Gold 3U"
 - 04: Selective Gold 5U"
 - 05: Selective Gold 15U"
 - 06: Selective Gold 30U"

产品图 PRODUCT CHART DWG		深圳市精拓金电子有限公司								
公差一览表 TOLERANCE UNLESS OTHERWISE				单位 UNITS	MM	制图 DRAWING	Z-Y-B	产品料号 PRODUCT PART NO.	903-242B2023S10210	
X.	±0.25	X'	±5'	比例 SCALE	1:1	审核 CHKD	日期 DATE	产品名称 PRODUCT NO.	AF无后盖直脚有边内弹14.0铜壳反向一型加宽LCP黑胶SMT	
.X	±0.20	.X'	±2'						核准 APPD	角法 VIEW
.XX	±0.15	.XX'	±1'	2015.03.14	⊕					
.XXX	±0.10	.XXX'	±0.5'							