

PLEASE CHECK WWW.MOLEX.COM FOR LATEST PART INFORMATION

Part Number: [0901512216](#)
Status: **Active**
Overview: [cgrid_sl_products](#)
Description: 2.54mm (.100") Pitch C-Grid III™ PC Board Connector, Dual Row, Vertical, 16 Circuits

Documents:

[3D Model](#)
[Drawing \(PDF\)](#)

[RoHS Certificate of Compliance \(PDF\)](#)

General

Product Family	PCB Receptacles
Series	90151
Application	Board-to-Board
Overview	cgrid_sl_products
Product Name	C-Grid III™

Physical

Circuits (Loaded)	16
Color - Resin	Black
Glow-Wire Compliant	No
Guide to Mating Part	No
Keying to Mating Part	None
Lock to Mating Part	No
Material - Metal	Phosphor Bronze
Material - Plating Mating	Gold
Material - Plating Termination	Tin
Material - Resin	Polyester
Number of Rows	2
Orientation	Vertical
PC Tail Length (in)	0.114 In
PC Tail Length (mm)	2.90 mm
PCB Locator	No
PCB Retention	None
PCB Thickness Recommended (in)	0.062 In
PCB Thickness Recommended (mm)	1.60 mm
Packaging Type	Tube
Pitch - Mating Interface (in)	0.100 In
Pitch - Mating Interface (mm)	2.54 mm
Plating min: Mating (µin)	15.2
Plating min: Mating (µm)	0.38
Plating min: Termination (µin)	120
Plating min: Termination (µm)	3
Polarized to PCB	No
Temperature Range - Operating	-55°C to +125°C
Termination Interface: Style	Through Hole

Electrical

Current - Maximum per Contact	3A
Grounding to PCB	No
Voltage - Maximum	350V

Solder Process Data

Lead-free Process Capability	Wave Capable (TH only)
------------------------------	------------------------

Material Info

Reference - Drawing Numbers

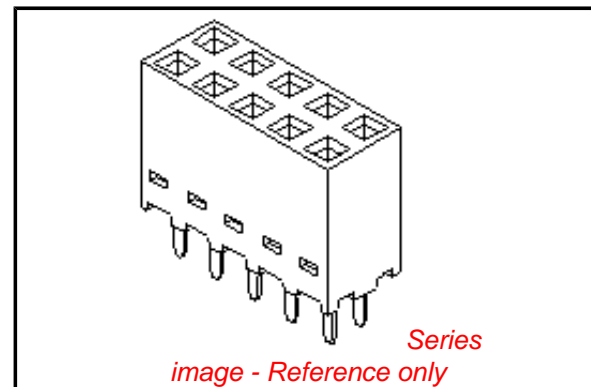

EU RoHS

ELV and RoHS Compliant
REACH SVHC
Contains SVHC: No
Halogen-Free Status

China RoHS



Need more information on product environmental compliance?

Email productcompliance@molex.com
 For a multiple part number RoHS Certificate of Compliance, [click here](#)

Please visit the [Contact Us](#) section for any non-product compliance questions.

Search Parts in this Series

[90151Series](#)

Mates With

0.64mm (.025") square pins

This document was generated on 05/24/2010

PLEASE CHECK WWW.MOLEX.COM FOR LATEST PART INFORMATION

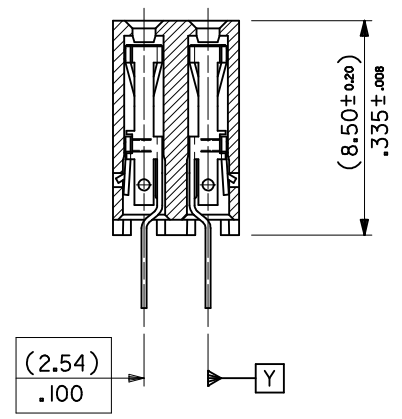
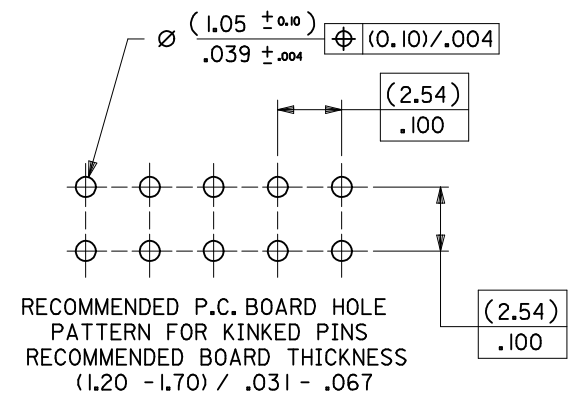
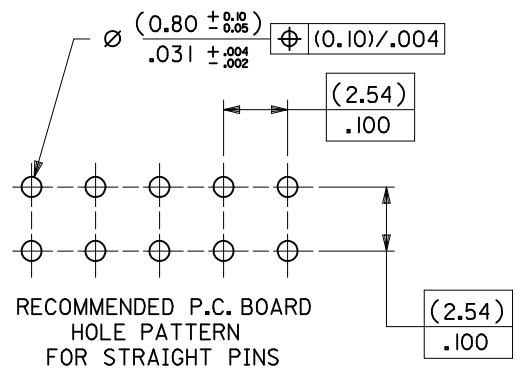
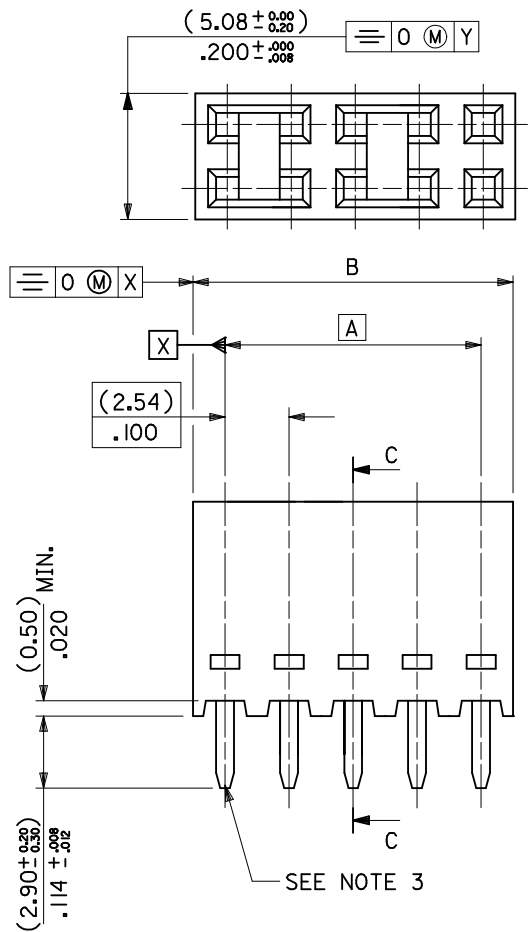

SECTION C-C

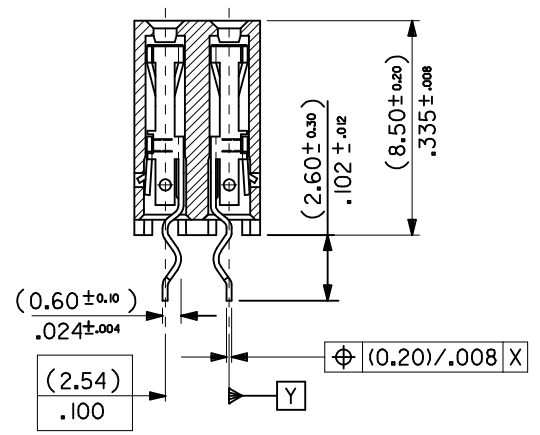

SECTION C-C

NOTES

- 1) CONTACT-PLATED PHOSPHOR BRONZE.
- 2) HOUSING-15% GLASS FILLED POLYESTER. COLOUR-BLACK.
- 3) COMPATIBLE WITH PCB HOLE PATTERN.
- 4) FOR (0.635)/.025 SQ. MALE PINS THE LENGTH MUST BE (5.65)/.222 MIN & (7.00)/.276 MAX. TO ENSURE GOOD CONNECTION WITH CONTACT.

6	AF
5	AD
4	AD
3	AD
2	AG
1	AH

ADD INSET FOR GATE EC NO: E2009-0250 DRWN: BMAGUIRE 2008/12/08 CHKD: 2008/12/08 APPR: BMAGUIRE 2008/12/08	QUALITY SYMBOLS ▽=0 ◻=0	GENERAL TOLERANCES (UNLESS SPECIFIED)		DIMENSION STYLE MM ONLY		SCALE 1:1		DESIGN UNITS METRIC		THIRD ANGLE PROJECTION																
		<table border="1"> <thead> <tr> <th></th> <th>mm</th> <th>INCH</th> </tr> </thead> <tbody> <tr> <td>4 PLACES</td> <td>± ---</td> <td>± ---</td> </tr> <tr> <td>3 PLACES</td> <td>± ---</td> <td>± ---</td> </tr> <tr> <td>2 PLACES</td> <td>± 0.05</td> <td>± ---</td> </tr> <tr> <td>1 PLACE</td> <td>± 0.10</td> <td>± ---</td> </tr> </tbody> </table>			mm	INCH	4 PLACES	± ---	± ---	3 PLACES	± ---	± ---	2 PLACES	± 0.05	± ---	1 PLACE	± 0.10	± ---	DRAWN BY DB		DATE 21/07/86		TITLE C-GRID III DUAL ROW VERTICAL P.C. BOARD CONNECTOR			
			mm	INCH																						
		4 PLACES	± ---	± ---																						
3 PLACES	± ---	± ---																								
2 PLACES	± 0.05	± ---																								
1 PLACE	± 0.10	± ---																								
DRAFT WHERE APPLICABLE MUST REMAIN WITHIN DIMENSIONS		APPROVED BY		DATE		MOLEX INCORPORATED																				
AH		REV		MATERIAL NO. SEE CHART		DOCUMENT NO. SDA-90151		SHEET NO. 1 OF 5																		

SEE CHART
PART NO. SDA-90151
DWG. NO.

PART NO. STRAIGHT PINS	PART NO. KINKED PINS	NO.OF CKTS.	DIM." A"	DIM." B" (± 0.00): ± 0.02	QTY. PER TUBE
90151-2X04	90151-3X04	4	(2.54) .100	(5.08) .200	105
▲ ▲ 06	▲ ▲ 06	6	(5.08) .200	(7.62) .300	72
08	08	8	(7.62) .300	(10.16) .400	52
10	10	10	(10.16) .400	(12.70) .500	44
12	12	12	(12.70) .500	(15.24) .600	36
14	14	14	(15.24) .600	(17.78) .700	30
16	16	16	(17.78) .700	(20.32) .800	26
18	18	18	(20.32) .800	(22.86) .900	24
20	20	20	(22.86) .900	(25.40) 1.000	22
22	22	22	(25.40) 1.000	(27.94) 1.100	20
24	24	24	(27.94) 1.100	(30.48) 1.200	18
26	26	26	(30.48) 1.200	(33.02) 1.300	16
28	28	28	(33.02) 1.300	(35.56) 1.400	14
30	30	30	(35.56) 1.400	(38.10) 1.500	14
32	32	32	(38.10) 1.500	(40.64) 1.600	13
34	34	34	(40.64) 1.600	(43.18) 1.700	12
36	36	36	(43.18) 1.700	(45.72) 1.800	12
38	38	38	(45.72) 1.800	(48.26) 1.900	11
40	40	40	(48.26) 1.900	(50.80) 2.000	11
42	42	42	(50.80) 2.000	(53.34) 2.100	11
44	44	44	(53.34) 2.100	(55.88) 2.200	10
46	46	46	(55.88) 2.200	(58.42) 2.300	10
48	48	48	(58.42) 2.300	(60.96) 2.400	9
50	50	50	(60.96) 2.400	(63.50) 2.500	8
52	52	52	(63.50) 2.500	(66.04) 2.600	8
54	54	54	(66.04) 2.600	(68.58) 2.700	8
56	56	56	(68.58) 2.700	(71.12) 2.800	7
58	58	58	(71.12) 2.800	(73.66) 2.900	7
60	60	60	(73.66) 2.900	(76.20) 3.000	7
▼ ▼ 62	▼ ▼ 62	62	(76.20) 3.000	(78.74) 3.100	7
90151-2X64	90151-3X64	64	(78.74) 3.100	(81.28) 3.200	6

PLATING VERSION A

PRE-PLATED HOT DIP TIN
1.0 TO 2.5 um (.000040" TO .000100").

PLATING VERSION E

1.27 TO 1.78 um (.000050" TO .000070") NICKEL
OVERALL, 0.38 TO 0.64 um (.000015" TO .000025")
GOLD ON CONTACT AREA (OVER NICKEL).
3 TO 5 um (.000120" TO .000200") TIN
ON SOLDER TAILS (OVER NICKEL).

PLATING VERSION F.

1.27 TO 1.78 um (.000050" TO .000070") NICKEL
OVERALL, 0.76 TO 1.0 um (.000030" TO .000040")
GOLD ON CONTACT AREA (OVER NICKEL).
3 TO 5 um (.000120" TO .000200") TIN
ON SOLDER TAILS (OVER NICKEL).

PLATING VERSION G.

1.27 TO 1.78 um (.000050" TO .000070") NICKEL
OVERALL, 0.125 um MIN. (.000005" MIN.) GOLD FLASH
ON CONTACT AREA (OVER NICKEL).
3 TO 5 um (.000120" TO .000200") TIN
ON SOLDER TAILS (OVER NICKEL).

PLATING VERSION N.

1.27 TO 1.78 um (.000050" TO .000070") NICKEL
OVERALL, 0.76 TO 2.6 um (.000030" TO .000100")
GOLD ON CONTACT AREA (OVER NICKEL).
4 um (.000120") MINIMUM TIN
ON SOLDER TAILS (OVER NICKEL).

STANDARD PRODUCTS

90151-XXYY

INDICATES NO. OF CIRCUITS.

- PLATING CODE.
1 = VERSION A.
2 = VERSION E.
3 = VERSION F.
4 = VERSION N.
5 = VERSION G.

SEE CHART

FOR PREVIOUS
DRAWING ISSUES
SEE MRI.

LEAD FREE CONVERSION
NEW BORDER ADDED
Ec NO. E2004-0610
DRAWN: PSHEAHAN 06/01/2004
CHK:
APPR:
AH
REV

DESCRIPTION
MAJOR
CRITICAL
C

QUALITY SYMBOLS
GENERAL TOLERANCES:
(UNLESS SPECIFIED)
SCALE
DESIGN UNITS
THIRD ANGLE PROJECTION
DRAWN BY & DATE
CHECKED BY & DATE
APPROVED BY & DATE
CAD FILENAME
MATERIAL NO.
DRAWING NO.
SHEET NO.
DRAFT WHERE APPLICABLE MUST
REMAIN WITHIN DIMENSIONS
THIS DRAWING CONTAINS INFORMATION THAT IS PROPRIETARY TO MOLEX
INCORPORATED AND SHOULD NOT BE USED WITHOUT WRITTEN PERMISSION.

DIMENSIONS: <input type="checkbox"/> mm <input type="checkbox"/> INCH <input type="checkbox"/> mm ONLY		SHT	REV
<input type="checkbox"/> mm <input type="checkbox"/> INCH <input type="checkbox"/> mm ONLY		REVISE ON CAD ONLY	
DRAWN BY & DATE DB 14/ 7/87		TITLE: C-GRID III DUAL ROW VERTICAL P.C. BOARD CONNECTOR	
CHECKED BY & DATE		MOLEX MOLEX INCORPORATED	
APPROVED BY & DATE		MATERIAL NO. SEE CHART	
ANGULAR: ± °		DRAWING NO. SDA-90151	
CAD FILENAME SA90151X2 DGN		SHEET NO. 20F	
DRAFT WHERE APPLICABLE MUST REMAIN WITHIN DIMENSIONS			
THIS DRAWING CONTAINS INFORMATION THAT IS PROPRIETARY TO MOLEX INCORPORATED AND SHOULD NOT BE USED WITHOUT WRITTEN PERMISSION.			
			SIZE B