

## Sensor/actuator box - SACB- 8/4-L-10,0PUR-M8 HD - 1197319

Please be informed that the data shown in this PDF Document is generated from our Online Catalog. Please find the complete data in the user's documentation. Our General Terms of Use for Downloads are valid (<http://phoenixcontact.com/download>)



Sensor/actuator box, application: Standard, connection method: M8 socket Metal, number of slots: 8, number of positions: 4, coding: A - standard, slot assignment: Double, status display: yes, pnp; master cable connection: Fixed connection 180°, PUR/PVC, cable length: 10 m, shielding: no

### Your advantages

- ✓ Safety in the field, thanks to molded housing and high degree of protection
- ✓ Convenient: increased machine availability thanks to quick and easy diagnostics
- ✓ Save space: distributor box with double occupancy for two sensors in one slot



### Key Commercial Data

Packing unit	1 pc
GTIN	 4 063151 254773
GTIN	4063151254773
Weight per Piece (excluding packing)	1,560.000 g
Custom tariff number	85444290
Country of origin	Germany

### Technical data

#### General

Rated voltage	24 V DC
Max. operating voltage $U_{max}$	30 V DC
Current carrying capacity per I/O signal	2 A
Current carrying capacity per slot	2 A
Total rated current	6 A
Number of positions	4

## Sensor/actuator box - SACB- 8/4-L-10,0PUR-M8 HD - 1197319

### Technical data

#### General

Number of slots	8
Sensor/actuator connection system	M8 socket
Note	NOTE: Observe the permissible bending radii when laying conductors, since the degree of protection may be put in jeopardy if the bending forces are too high. Alleviate mechanical loads upstream of the connector, e.g. by using cable ties.
	Unused slots are to be sealed off prior to commissioning. Suitable sealing elements are to be found under "Accessories".

#### Ambient conditions

Degree of protection	IP67
Ambient temperature (operation)	-25 °C ... 80 °C

#### Local diagnostics function

Local diagnostics	Supply voltage Green LED
	Status display I/O Yellow LED

#### Master cable connection data

Connection method	Fixed connection
Length of cable	10 m
Tightening torque slot sensor/actuator cable	0.2 Nm

#### Insulation material

Housing material	PBT
Material of the moulding mass	PUR
Contact material	CuZn
Contact surface material	Ni/Au
Contact carrier material	PBT
Material of threaded sleeve	Cu alloy
Material of threaded sleeve surface	Nickel-plated
O-ring material	FKM

#### Pin assignment

Slot/position = Wire color or connection	1 / 4 (A) = WH
	1 / 2 (B) = GY/PK
	2 / 4 (A) = GN
	2 / 2 (B) = RD/BU
	3 / 4 (A) = YE
	3 / 2 (B) = WH/GN
	4 / 4 (A) = GY
	4 / 2 (B) = BN/GN

## Sensor/actuator box - SACB- 8/4-L-10,0PUR-M8 HD - 1197319

### Technical data

#### Pin assignment

	5 / 4 (A) = PK
	5 / 2 (B) = WH/YE
	6 / 4 (A) = RD
	6 / 2 (B) = YE/BN
	7 / 4 (A) = BK
	7 / 2 (B) = WH/GY
	8 / 4 (A) = VT
	8 / 2 (B) = GY/BN
	1-8 / 1 (+ 24 V) = BN
	1-8 / 3 (0 V) = BU

#### Standards and Regulations

Standards/specifications	M8 connector IEC 61076-2-104
--------------------------	------------------------------

#### Cable

Cable type	Master cable suitable for flexible cable conduit
Cable abbreviation	LiYY11Y-HF
UL AWM style	20549
Conductor cross section	16x 0.34 mm <sup>2</sup> (Signal line) 2x 0.75 mm <sup>2</sup> (power line)
AWG signal line	22
AWG power supply	18
Conductor structure signal line	19x 0.15 mm
Conductor structure, voltage supply	42x 0.15 mm
Core diameter including insulation	1.3 mm ±0.1 mm (Signal line) 1.8 mm ±0.1 mm (power line)
Thickness, insulation	≥ 0.15 mm (Inner sheath) ≥ 0.76 mm (Outer cable sheath)
Overall twist	Wires twisted in layers
External cable diameter D	9.5 mm ±0.2 mm
Smallest bending radius, fixed installation	95 mm
Smallest bending radius, movable installation	95 mm
Minimum bending radius, fixed installation	7.5 x D
Minimum bending radius, flexible installation	10 x D
Number of bending cycles	1500000
Bending radius	95 mm
Traversing path	2 m
Traversing rate	2 m/s

# Sensor/actuator box - SACB- 8/4-L-10,0PUR-M8 HD - 1197319

## Technical data

### Cable

Cable weight	143.9 kg/km
External sheath, color	black RAL 9005
Outer sheath, material	PUR
Material, inner sheath	PVC
Material conductor insulation	PVC
Conductor material	Bare Cu litz wires
Nominal voltage, cable	300 V
Test voltage, cable	2000 V
Special properties	Silicone-free
Other resistance	Highly resistant to acids, alkaline solutions and solvents
Flame resistance	DIN EN 50265
Resistance to oil	according to VDE 0472 Part 803
Ambient temperature (operation)	-40 °C ... 90 °C (cable, fixed installation)
	-5 °C ... 80 °C (Cable, flexible installation)

### Environmental Product Compliance

China RoHS	Environmentally Friendly Use Period = 50 years
	For details about hazardous substances go to tab "Downloads", Category "Manufacturer's declaration"

## Drawings

Schematic diagram

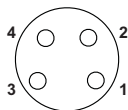

M8 slot, socket, 4-pos.

Circuit diagram

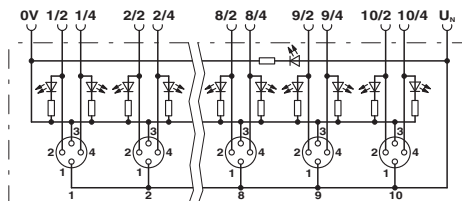

# Sensor/actuator box - SACB- 8/4-L-10,0PUR-M8 HD - 1197319

Dimensional drawing

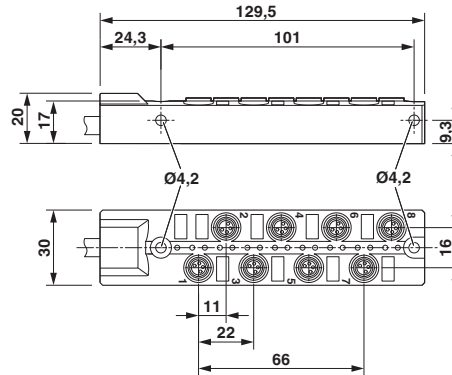

## Classifications

eCl@ss

eCl@ss 10.0.1	27440108
eCl@ss 11.0	27440108
eCl@ss 9.0	27440108

ETIM

ETIM 7.0	EC002585
----------	----------

## Approvals

Approvals

Approvals

UL Recognized / cUL Recognized / cULus Recognized

Ex Approvals

## Approval details

UL Recognized		<a href="http://database.ul.com/cgi-bin/XYV/template/LISEXT/1FRAME/index.htm">http://database.ul.com/cgi-bin/XYV/template/LISEXT/1FRAME/index.htm</a>	E238705
---------------	--	---	---------

## Sensor/actuator box - SACB- 8/4-L-10,0PUR-M8 HD - 1197319

### Approvals

cUL Recognized		<a href="http://database.ul.com/cgi-bin/XYV/template/LISEXT/1FRAME/index.htm">http://database.ul.com/cgi-bin/XYV/template/LISEXT/1FRAME/index.htm</a>	E238705
----------------	--	---	---------

cULus Recognized			
------------------	--	--	--

### Accessories

#### Accessories

##### Labeled terminal marker

Marker for terminal blocks - UCT1U-TM 5 CUS - 8191012



Markers for terminal blocks, for marking terminal blocks from Weidmüller, Conta Clip, and Klemsan, 72-section, offset foot, can be ordered in sheet form, marked according to customer specifications, color: white

##### Plug for cable screw gland

Screw plug - PROT-M8 - 1682540



An M8 screw plug for the unoccupied M8 sockets of the sensor/actuator cable, boxes and flush-type connectors

##### Screwdriver tools

Tool - SAC BIT M8-D10 - 1208461



Nut for assembling M8 connectors with longitudinal knurl and a knurl diameter of 10 mm, for 4 mm hexagonal drive

## Sensor/actuator box - SACB- 8/4-L-10,0PUR-M8 HD - 1197319

### Accessories

Tool - SACC BIT M8-D12 - 1208474



Nut for assembling M8 connectors with longitudinal knurl and a knurl diameter of 12 mm, for 4 mm hexagonal drive

---

### Stripping tool

Stripping tool - WIREFOX-D 40 - 1212161



Stripping tool, for stripping cables of 4.5 mm - 40 mm-Ø, insulation thickness of up to 4.5 mm, pivoting blade for round, lengthwise, and spiral cuts

---

Stripping tool - WIREFOX-D 11 - 1212160



Stripping tool, for stripping multicore signal, control and fiberglass wires of Ø 2.5 - 11 mm. Insulation thickness up to 1 mm

---

Stripping tool - WIREFOX-D 13 - 1212162



Stripping tool, for stripping installation lines of Ø 8 - 13 mm , e.g. NYM 3 x 1.5 mm<sup>2</sup> to 5 x 2.5 mm<sup>2</sup>, single line stripping 0.2 mm<sup>2</sup> - 4 mm<sup>2</sup> , with longitudinal cut blade and sliding knife

---

Stripping tool - WIREFOX-MP VDE - 1212528



Multifunction stripping tool, for removing the jacket from cables with a diameter of 8 to 13 mm, for stripping cables with a cross section of 0.2 to 10 mm<sup>2</sup>, with full-fledged diagonal cutter, VDE 1000 V AC/1500 V DC tested

---

## Sensor/actuator box - SACB- 8/4-L-10,0PUR-M8 HD - 1197319

### Accessories

Stripping tool - WIREFOX 2,5 - 1212368



Stripping tool, for conductors and cables with a conductor cross section from 0.08 to 2.5 mm, self-adjusting, stripping length adjustable up to 15 mm, cutting capacity up to 6 mm<sup>2</sup> stranded/1.5 mm<sup>2</sup> solid

---

### Terminal marking

Marker for terminal blocks - UCT1U-TM 5 - 0803204



UniCard materials for thermal transfer printers, for marking terminal blocks from Weidmüller, Conta Clip, and Klemsan, 72-section, offset foot, can be marked with THERMOMARK CARD and BLUEMARK, color: white

---

### Torque tool

Torque screwdriver - TSD 02 SAC - 1208487



Torque screwdriver, with preset torque of 0.2 Nm and 4 mm hexagonal drive for M8 connectors