

# ULTRA SMALL HIGH VOLTAGE DC RELAY

## FTR-J2 Series

RoHS compliant

### ■ FEATURES

- 10A, 450V DC high-voltage switching
- Contact voltage drop: typical 0.1V
- Inrush Current 150A (Capacitive load )
- Compact size ( L x W x H = 24 x 23.5 x 27mm )
- 2 x 1 form A
- Coil sensitivity 1W
- High insulation between contacts and coil
  - Insulation distance : Clearance/creepage > 6mm
  - Dielectric strength : 4,000 VAC
  - Surge strength : 10,000 V
- Plastic materials conform to UL94 flame class V-0
- RoHS Compliant
- Optional transparent cover



### ■ ORDERING INFORMATION

[Example]      FTR-J2    A   K   012   W - RG  
                   (a)    (b) (c) (d) (e) (f)

(a)	Series name	FTR-J2 series
(b)	Contact arrangement	A: 2 x 1 form A
(c)	Coil	K: Standard sensitivity
(d)	Nominal coil voltage	Please refer to COIL DATA CHART
(e)	Contact material	W: silver alloy
(f)	Optional	RG: Transparent cover

Note: The designation name is printed on the top of the relay as follows:

(Example:      Ordered type: FTR-J2AK012W  
                   Printing: J2AK012W

# FTR-J2 Series

## ■ COIL DATA CHART 1

2 coils in series (10A, 450VDC configuration)

Part Number	Nominal Voltage (VDC)	Coil Resistance ( $\pm 10\%$ )	Must Operate Voltage	Must Release Voltage	Nominal Power ( $\pm 10\%$ )
FTR-J2AK005W	10	94 $\Omega$	7.0 VDC	0.5 VDC	Approximately 1.06W
FTR-J2AK006W	12	136 $\Omega$	8.4 VDC	0.6 VDC	
FTR-J2AK012W	24	540 $\Omega$	16.8 VDC	1.2 VDC	
FTR-J2AK024W	48	2,200 $\Omega$	33.6 VDC	2.4 VDC	
FTR-J2AK048W	96	8,800 $\Omega$	67.2 VDC	4.8 VDC	
FTR-J2AK060W	120	13,580 $\Omega$	84.0 VDC	6.0 VDC	
FTR-J2AK110W	220	45,600 $\Omega$	154.0 VDC	11.0 VDC	

Note 1: Nominal voltage is different from indication of part number. Please refer to the COIL DATA CHART 2 for single coil configuration data.

Note 2: All values in the table valid at 20°C ambient temperature.

## ■ COIL DATA CHART 2

Single coil (10A, 200VDC configuration)

Part Number	Nominal Voltage (VDC)	Coil Resistance ( $\pm 10\%$ )	Must Operate Voltage	Must Release Voltage	Nominal Power ( $\pm 10\%$ )
FTR-J2AK005W	5	47 $\Omega$	3.5 VDC	0.25 VDC	Approximately 0.53W
FTR-J2AK006W	6	68 $\Omega$	4.2 VDC	0.3 VDC	
FTR-J2AK012W	12	270 $\Omega$	8.4 VDC	0.6 VDC	
FTR-J2AK024W	24	1,100 $\Omega$	16.8 VDC	1.2 VDC	
FTR-J2AK048W	48	4,400 $\Omega$	33.6 VDC	2.4 VDC	
FTR-J2AK060W	60	6,790 $\Omega$	42.0 VDC	3.0 VDC	
FTR-J2AK110W	110	22,800 $\Omega$	77.0 VDC	5.5 VDC	

Note: All values in the table valid at 20°C ambient temperature.

## ■ SCHEMATICS

Connection on PCB

2 coils in series

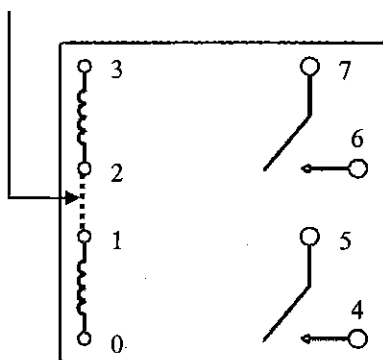

COIL DATA CHART 1

Each relay section is used independently

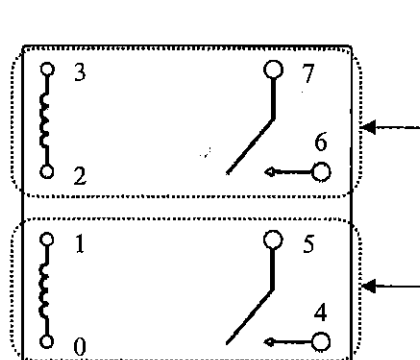

COIL DATA CHART 2

Bottom view

# FTR-J2 Series

## ■ SPECIFICATIONS

		FTR-J2 series	
		FTR-J2AK ( )W	
Contact	Arrangement	2 x 1 form A	
	Contact material	Silver alloy	
	Rating (refer to CIRCUIT)	10A, 450VDC (resistive load) + polarity pin 7 and 4 * each NO contact connected in series	
		10A, 200VDC (resistive load) (single contact) + polarity pin 7 and 4	
	Overload switching	10A, 500VDC (resistive load) * each NO contact connected in series	
	Maximum carrying current	12A	
	Inrush current	Peak 150A (capacitive load / 340VDC, 1410μ F)	
	Contact voltage drop	Typical 0.1V (at nominal contact current)	
Coil	Operate voltage (at 20°C)	Maximum 70% of nominal voltage	
	Release voltage (at 20°C)	Minimum 5% of nominal voltage	
	Operating temperature (no frost)	-40°C to +85°C	
		-40°C to +70°C, "-RG" transparent cover version	
Time value	Operate (at nominal voltage)	15ms maximum, excluding contact bounce time	
	Release (at nominal voltage)	5ms maximum	
Insulation	Resistance	Minimum 1,000MΩ (at 500VDC)	
	Dielectric strength	between open contacts	1,000 VAC (50/60 Hz) 1 min.
		between contact sets	4,000 VAC (50/60 Hz) 1 min.
		between contacts and coil	1,000 VAC (50/60 Hz) 1 min.
Surge strength	between contact and coil	10,000 V (1.2 x 50μ s)	
Life	Electrical	10K operations (10A, 450VDC at resistive load)	
	Mechanical	2M operations	
Vibration resistance	Endurance	10 to 55 Hz at double amplitude of 1.5 mm	
	Misoperation	10 to 55 Hz at double amplitude of 1.5 mm	
Shock resistance	Endurance	200 m/s <sup>2</sup> (11±1ms)	
	Misoperation	1,000 m/s <sup>2</sup> (6±1ms)	
Weight		Approximately 26 g	

Note: Use a varistor as a protective circuit against reverse surge connected parallel to the coil. The reverse blocking voltage should be about 3 times the value of the power source voltage.

## ■ SAFETY STANDARDS

- **UL508**  
 10A, 450VDC, resistive, 10,000 cycles for series connection of each NO contact  
 10A, 400VDC, resistive, 10,000 cycles for series connection of each NO contact  
 10A, 200VDC, resistive, 10,000 cycles for each NO contact
- **VDE: 0435**  
 10A, 400VDC, resistive, 10,000 cycles for series connection of each NO contact  
 10A, 200VDC, resistive, 10,000 cycles for each NO contact

# FTR-J2 Series

## ■ DIMENSIONS

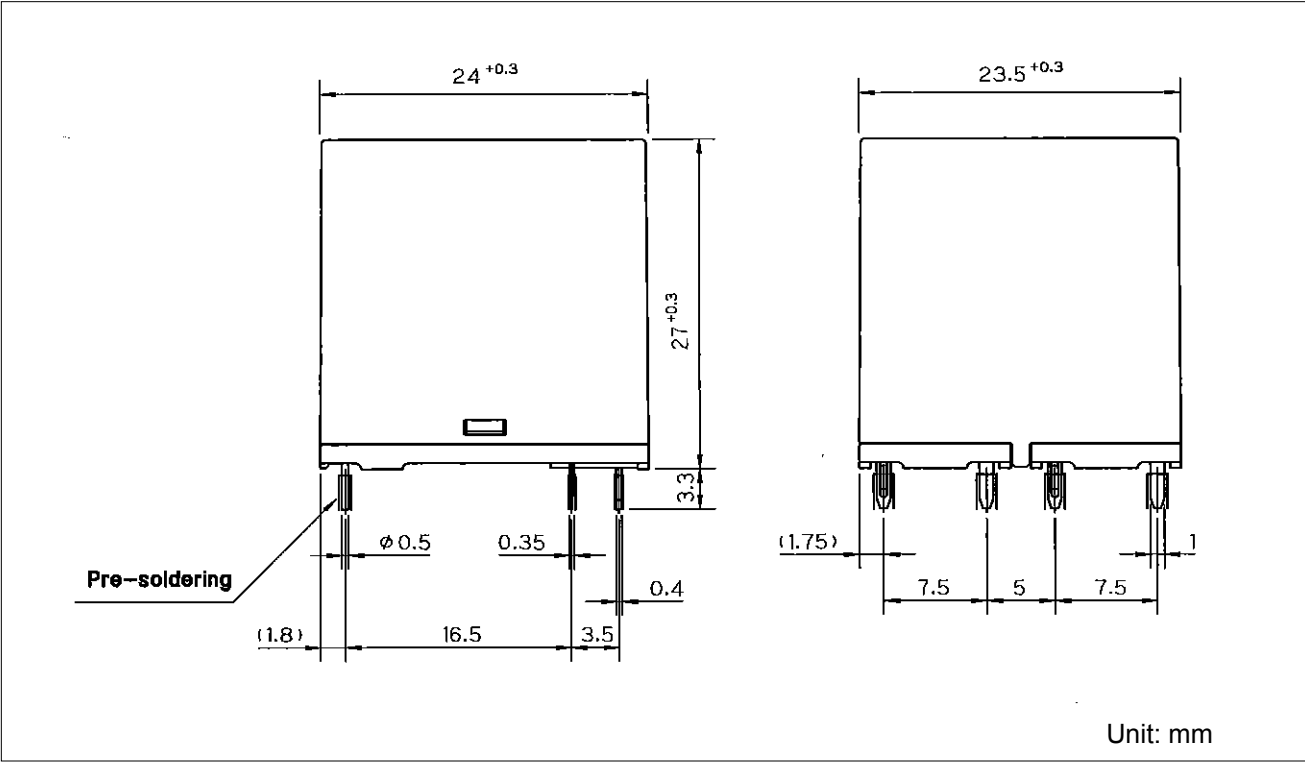

## ■ PC BOARD PATTERN

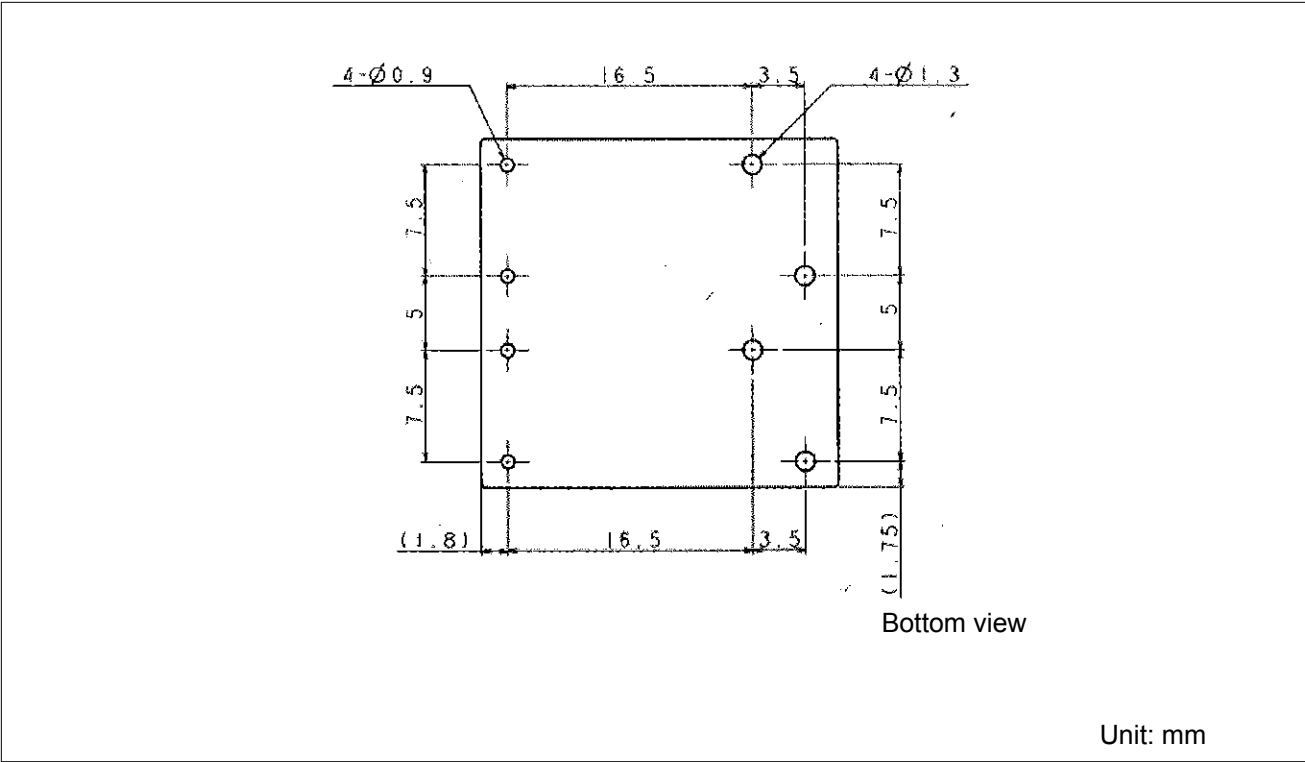

# FTR-J2 Series

## ■ CIRCUIT

- **Load sides and input sides (coil sides) for 10A, 450VDC**  
Please refer to COIL DATA CHART 1 for nominal coil voltage

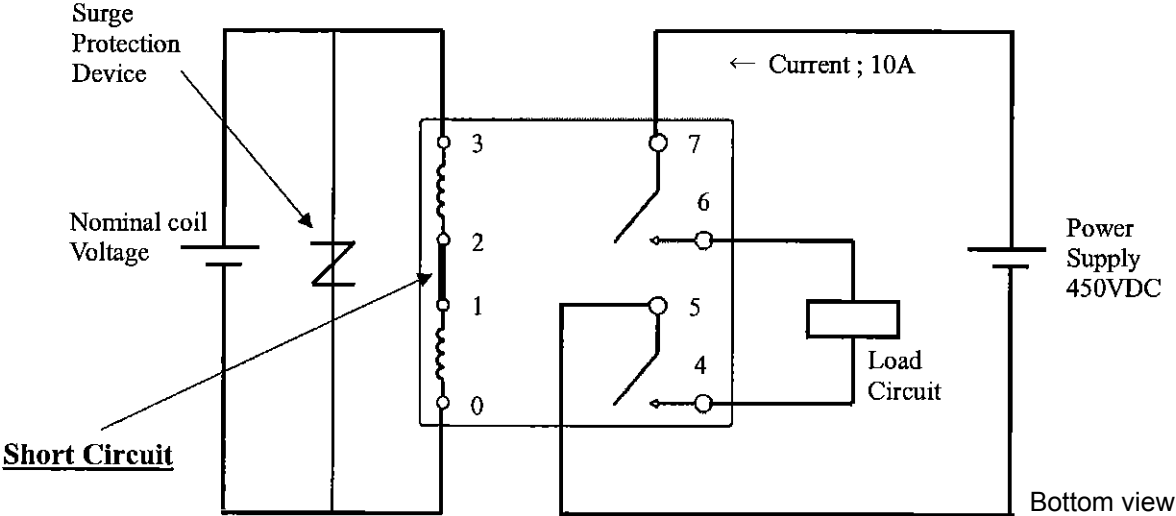

Note: Load sides have polarities (+) and (-). Input sides (coil sides) do not have polarities.

- **Load sides and input sides (coil sides) for 10A, 200VDC**  
Please refer to COIL DATA CHART 1 for nominal coil voltage

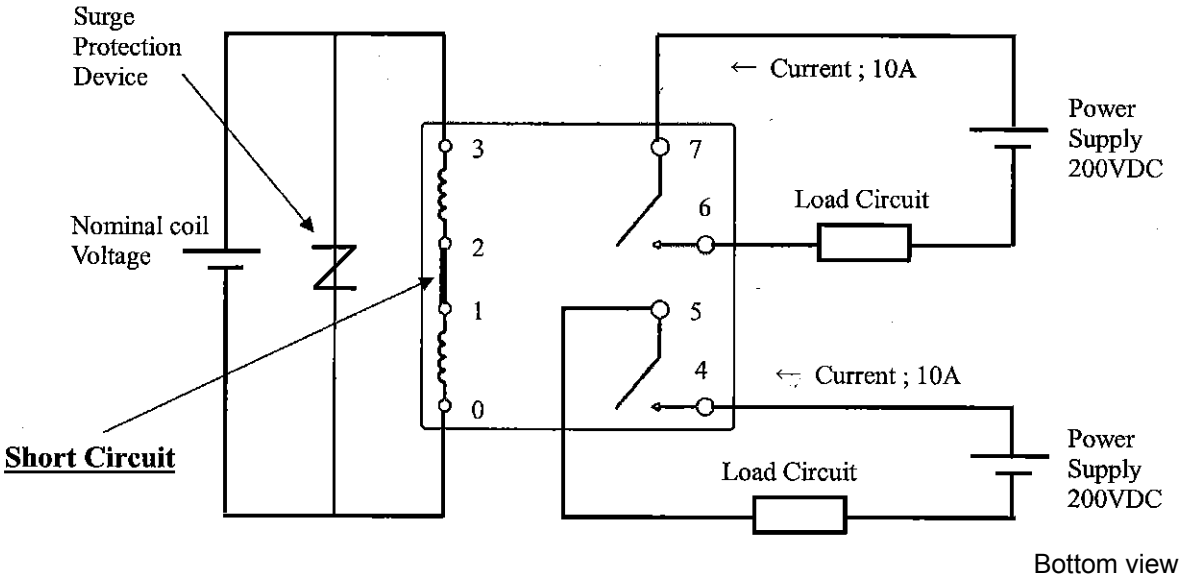

Note: Load sides have polarities (+) and (-). Input sides (coil sides) do not have polarities.

# FTR-J2 Series

## ■ CIRCUIT

- **Load sides and input sides (coil sides) for 10A, 200VDC**  
Please refer to COIL DATA CHART 2 for nominal coil voltage

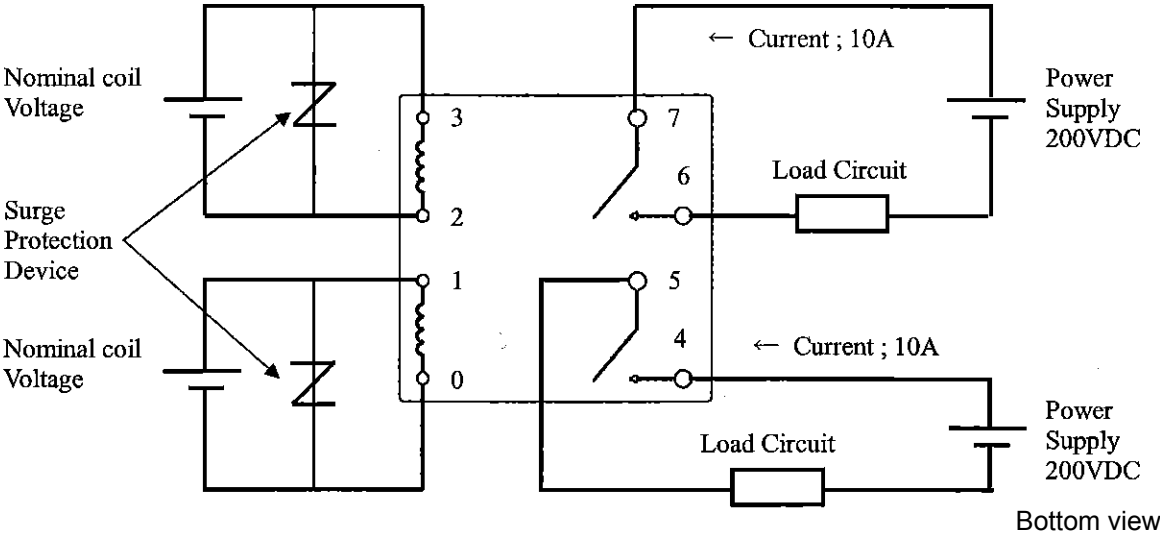

Note: You can use each NO contact independently  
Load sides have polarities (+) and (-). Input sides (coil sides) do not have polarities.

- **Load sides and input sides (coil sides) for 10A, 450VDC**  
Please refer to COIL DATA CHART 2 for nominal coil voltage

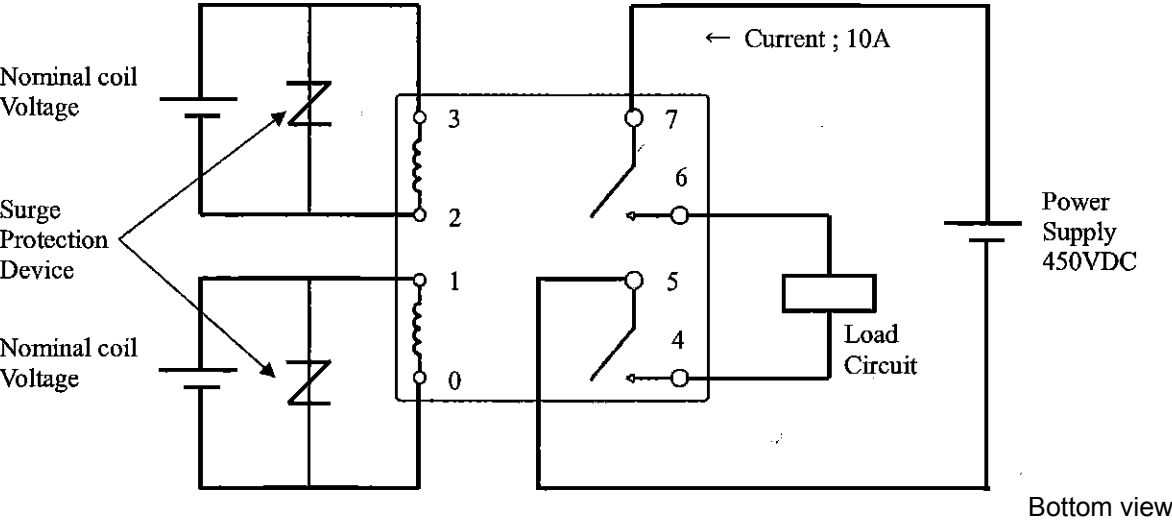

Note: Synchronized with a signal to coils of the relay operate / release  
Load sides have polarities (+) and (-). Input sides (coil sides) do not have polarities.

## RoHS Compliance and Lead Free Relay Information

### 1. General Information

- Relays produced after the specific date code that is indicated on each data sheet are lead-free now. All of our signal and power relays are lead-free. Please refer to Lead-Free Status Info. (<http://www.fujitsu.com/us/downloads/MICRO/fcai/relays/lead-free-letter.pdf>)
- Lead free solder paste currently used in relays is Sn-3.0Ag-0.5Cu.
- All signal and power relays also comply with RoHS. Please refer to individual data sheets. Relays that are RoHS compliant do not contain the 5 hazardous materials that are restricted by RoHS directive (lead, mercury, chromium IV, PBB, PBDE).
- It has been verified that using lead-free relays in leaded assembly process will not cause any problems (compatible).
- "LF" is marked on each outer and inner carton. (No marking on individual relays).
- To avoid leaded relays (for lead-free sample, etc.) please consult with area sales office.
- We will ship leaded relays as long as the leaded relay inventory exists.

Note: Cadmium was exempted from RoHS on October 21, 2005. (Amendment to Directive 2002/95/EC)

### 2. Recommended Lead Free Solder

- Recommended solder paste Sn-3.0Ag-0.5Cu.

#### Flow Solder condition

**Flow Solder condition:**

Pre-heating: maximum 120°C  
Soldering: dip within 5 sec. at  
260°C solder bath

**Solder by Soldering Iron:**

Soldering Iron  
Temperature: maximum 360°C  
Duration: maximum 3 sec.

**We highly recommend that you confirm your actual solder conditions**

### 3. Moisture Sensitivity

- Moisture Sensitivity Level standard is not applicable to electromechanical relays.

### 4. Tin Whisker

- Dipped SnAgCu solder is known as low risk tin whisker. No considerable length whisker was found by our in house test.

## Fujitsu Components International Headquarter Offices

### Japan

Fujitsu Component Limited  
Gotanda-Chuo Building  
3-5, Higashigotanda 2-chome, Shinagawa-ku  
Tokyo 141, Japan  
Tel: (81-3) 5449-7010  
Fax: (81-3) 5449-2626  
Email: [promothq@ft.ed.fujitsu.com](mailto:promothq@ft.ed.fujitsu.com)  
Web: [www.fcl.fujitsu.com](http://www.fcl.fujitsu.com)

### North and South America

Fujitsu Components America, Inc.  
250 E. Caribbean Drive  
Sunnyvale, CA 94089 U.S.A.  
Tel: (1-408) 745-4900  
Fax: (1-408) 745-4970  
Email: [components@us.fujitsu.com](mailto:components@us.fujitsu.com)  
Web: <http://www.fujitsu.com/us/services/edevices/components/>

### Europe

Fujitsu Components Europe B.V.  
Diamantlaan 25  
2132 WV Hoofddorp  
Netherlands  
Tel: (31-23) 5560910  
Fax: (31-23) 5560950  
Email: [info@fceu.fujitsu.com](mailto:info@fceu.fujitsu.com)  
Web: [emea.fujitsu.com/components/](http://emea.fujitsu.com/components/)

### Asia Pacific

Fujitsu Components Asia Ltd.  
102E Pasir Panjang Road  
#01-01 Citilink Warehouse Complex  
Singapore 118529  
Tel: (65) 6375-8560  
Fax: (65) 6273-3021  
Email: [fcac@fcal.fujitsu.com](mailto:fcac@fcal.fujitsu.com)  
Web: <http://www.fujitsu.com/sg/services/micro/components/>

©2009 Fujitsu Components America, Inc. All rights reserved. All trademarks or registered trademarks are the property of their respective owners.

Fujitsu Components America or its affiliates do not warrant that the content of datasheet is error free. In a continuing effort to improve our products Fujitsu Components America, Inc. or its affiliates reserve the right to change specifications/datasheets without prior notice.  
Rev. April 27, 2009.