

Features

- **Input Over-Voltage Protection**
- **Programmable Input Over-Current Protection**
- **Battery Over-Voltage Protection**
- **Over-Temperature Protection**
- **High Immunity of False Triggering**
- **High Accuracy Protection Thresholds**
- **Fault Status Indication**
- **Enable Input**
- **Available in TDFN2x2-8 Package**
- **Lead Free and Green Devices Available (RoHS Compliant)**

Applications

- **Smart Phones and PDAs**
- **Digital Still Cameras**
- **Portable Devices**

General Description

The APL3205A/B provide completed Li+ charger protections against over-voltage, over-current, and battery over-voltage. The IC is designed to monitor input voltage, input current, and battery voltage. When any of the monitored parameters are over the threshold, the IC removes the power from the charging system by turning off an internal switch. All protections also have deglitch time against false triggering due to voltage spikes or current triggering. The APL3205A/B also provide over-temperature protection, a $\overline{\text{FAULT}}$ output pin to indicate the fault conditions, and the $\overline{\text{EN}}$ pin to allow the system to disable the IC.

Pin Configuration

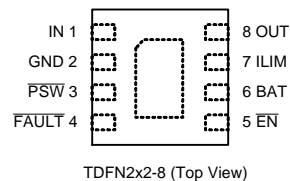

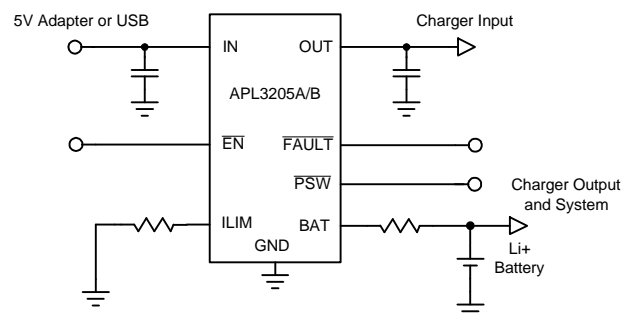

Simplified Application Circuit

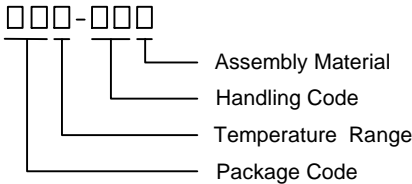

ANPEC reserves the right to make changes to improve reliability or manufacturability without notice, and advise customers to obtain the latest version of relevant information to verify before placing orders.

Ordering and Marking Information

APL3205A APL3205B		Package Code QB : TDFN2x2-8 Operating Ambient Temperature Range I : -40 to 85 °C Handling Code TR : Tape & Reel Assembly Material G : Halogen and Lead Free Device
APL3205A QB:		X - Date Code
APL3205B QB:		X - Date Code

Note : ANPEC lead-free products contain molding compounds/die attach materials and 100% matte tin plate termination finish; which are fully compliant with RoHS. ANPEC lead-free products meet or exceed the lead-free requirements of IPC/JEDEC J-STD-020C for MSL classification at lead-free peak reflow temperature. ANPEC defines "Green" to mean lead-free (RoHS compliant) and halogen free (Br or Cl does not exceed 900ppm by weight in homogeneous material and total of Br and Cl does not exceed 1500ppm by weight).

Absolute Maximum Ratings (Note 1)

Symbol	Parameter	Rating	Unit
V_{IN}	IN Input Voltage (IN pin to GND)	-0.3 to 30	V
V_{OUT}, V_{BAT}	OUT, BAT Pins to GND Voltage	-0.3 to 7	V
$V_{ILIM}, V_{FAULT}, V_{EN}, V_{PSW}$	ILIM, FAULT, EN, PSW, Pins to GND Voltage	-0.3 to 7	V
I_{OUT}	OUT Output Current	2	A
T_J	Maximum Junction Temperature	150	°C
T_{STG}	Storage Temperature Range	-65 to 150	°C
T_{SDR}	Maximum Lead Soldering Temperature, 10 Seconds	260	°C

Note 1 : Stresses beyond the absolute maximum rating may damage the device and exposure to absolute maximum rating conditions for extended periods may affect device reliability.

Thermal Characteristics

Symbol	Parameter	Typical Value	Unit
θ_{JA}	Junction to Ambient Thermal Resistance in Free Air TDFN2x2-8	80	°C/W

Recommended Operating Conditions

Symbol	Parameter	Range	Unit
V_{IN}	IN Input Voltage	4.5 to 5.5	V
I_{OUT}	OUT Output Current	0 to 1.5	A
T_J	Junction Temperature	-40 to 125	°C
T_A	Ambient Temperature	-40 to 85	°C

Electrical Characteristics

Refer to the typical application circuit. These specifications apply over $V_{IN}=5V$, $T_A=-40\sim 85^{\circ}C$, unless otherwise specified. Typical values are at $T_A=25^{\circ}C$.

Symbol	Parameter	Test Conditions	APL3205A/B			Unit
			Min.	Typ.	Max.	
POWER-ON-RESET (POR) AND SUPPLY CURRENT						
V_{POR}	IN POR Threshold	V_{IN} rising	2.5	-	2.8	V
V_{POR_HYS}	IN POR Hysteresis		-	230	-	mV
I_{CC}	IN Supply Current	\overline{EN} = Low	-	250	350	μA
		\overline{EN} = High	-	100	150	
$T_{B(IN)}$	Input Power-On Blanking Time	V_{IN} rising to V_{OUT} rising	-	8	-	ms
INTERNAL POWER SWITCH AND OUT DISCHARGE RESISTANCE						
	Power Switch On Resistance	$I_{OUT} = 0.5A$	-	250	450	$m\Omega$
	OUT Discharge Resistance	$V_{OUT} = 3V$	-	500	-	Ω
INPUT OVER-VOLTAGE PROTECTION (OVP)						
V_{OVP}	Input OVP Threshold	APL3205A, V_{IN} rising	5.67	5.85	6.00	V
		APL3205B, V_{IN} rising	6.60	6.80	7.00	
	Input OVP Recovery Hysteresis		-	200	-	mV
	Input OVP Propagation Delay		-	-	1	μs
$T_{ON(OVP)}$	Input OVP Recovery Time		-	8	-	ms
OVER-CURRENT PROTECTION (OCP)						
I_{OCP}	OCP Threshold	$R_{ILIM} = 25k\Omega$	930	1000	1200	mA
	OCP Threshold Accuracy	$I_{OCP} = 300mA$ to $1500mA$	-10	-	+10	%
$T_{B(OCP)}$	OCP Blanking Time		-	176	-	μs
$T_{ON(OCP)}$	OCP Recovery Time		-	64	-	ms
BATTERY OVER-VOLTAGE PROTECTION						
V_{BOVP}	Battery OVP Threshold	V_{BAT} rising	4.30	4.35	4.4	V
	Battery OVP Hysteresis		-	270	-	mV
I_{BAT}	BAT Pin Leakage Current	$V_{BAT} = 4.4V$	-	-	20	nA
$T_{B(BOVP)}$	Battery OVP Blanking Time		-	176	-	μs
EN LOGIC LEVELS						
	\overline{EN} Input Logic High		1.4	-	-	V
	\overline{EN} Input Logic Low		-	-	0.4	V
	\overline{EN} Internal Pull-Low Resistor		-	500	-	$k\Omega$
FAULT LOGIC LEVELS AND DELAY TIME						
	\overline{FAULT} Output Low Voltage	Sink 5mA current	-	-	0.4	V
	\overline{FAULT} Pin Leakage Current	$V_{\overline{FAULT}} = 5V$	-	-	1	μA
OVER-TEMPERATURE PROTECTION (OTP)						
T_{OTP}	Over-Temperature Threshold		-	140	-	$^{\circ}C$
	Over-Temperature Hysteresis		-	20	-	$^{\circ}C$
PSW LOGIC LEVELS						
	\overline{PSW} Output Low Threshold	V_{IN} rising, $V_{OUT} - V_{BAT}$	50	100	150	mV
	\overline{PSW} Output High Threshold	V_{IN} falling, $V_{OUT} - V_{BAT}$	20	50	80	mV

Electrical Characteristics (Cont.)

Refer to the typical application circuit. These specifications apply over $V_{IN}=5V$, $T_A=-40\sim 85^{\circ}C$, unless otherwise specified. Typical values are at $T_A=25^{\circ}C$.

Symbol	Parameter	Test Conditions	APL3205A/B			Unit
			Min.	Typ.	Max.	
PSW LOGIC LEVELS (CONT.)						
	\overline{PSW} Source Current	$V_{\overline{PSW}} = 2.5V$	-	2.5	-	mA
	\overline{PSW} Sink Current	$V_{\overline{PSW}} = 2.5V$	-	5	-	mA
$T_{D(PSW)}$	\overline{PSW} Low Delay Time	V_{IN} rising, $V_{OUT} - V_{BAT}$	-	1	-	ms

Typical Operating Characteristics

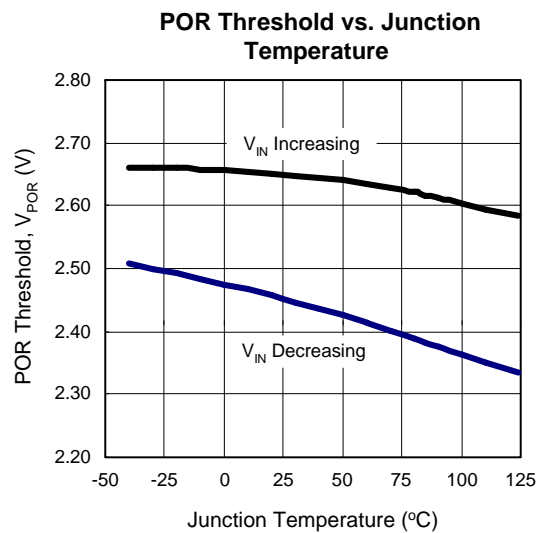
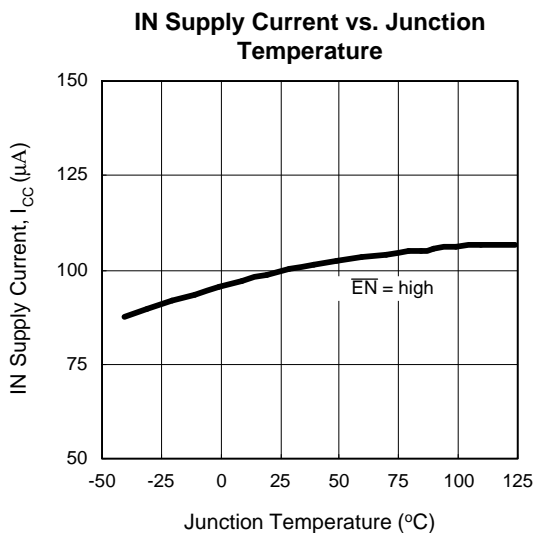
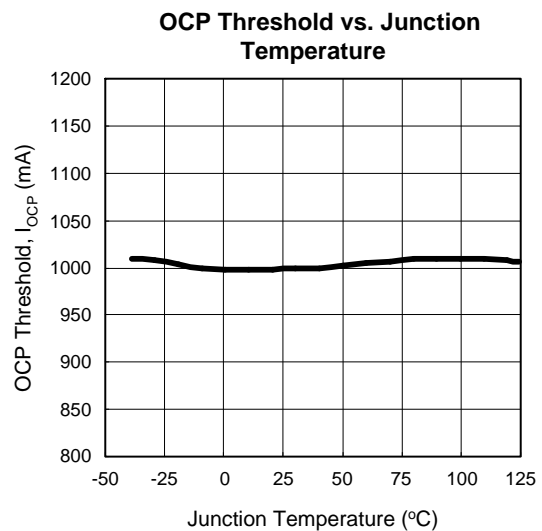
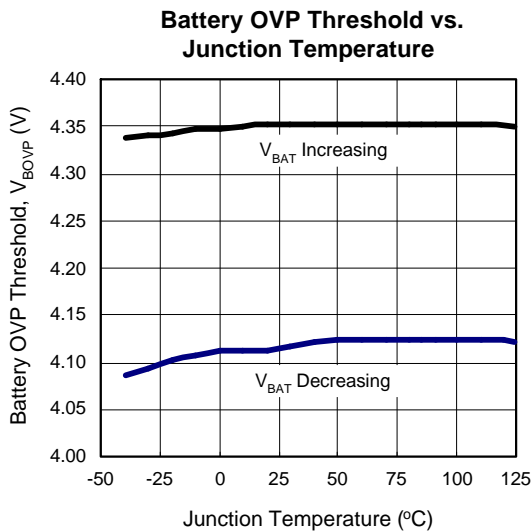
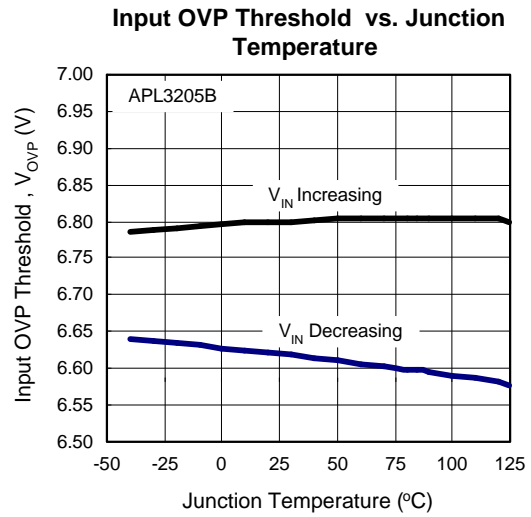
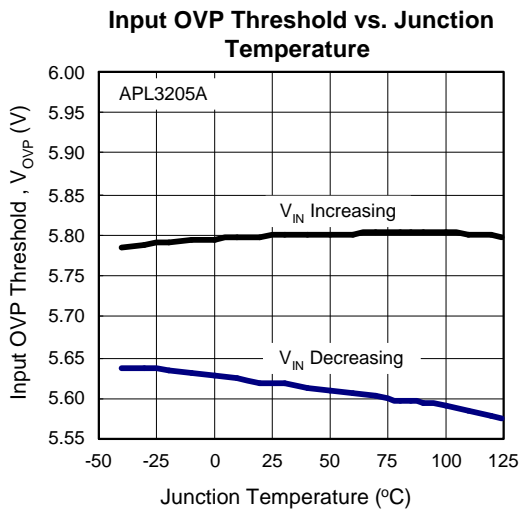

Typical Operating Characteristics (Cont.)

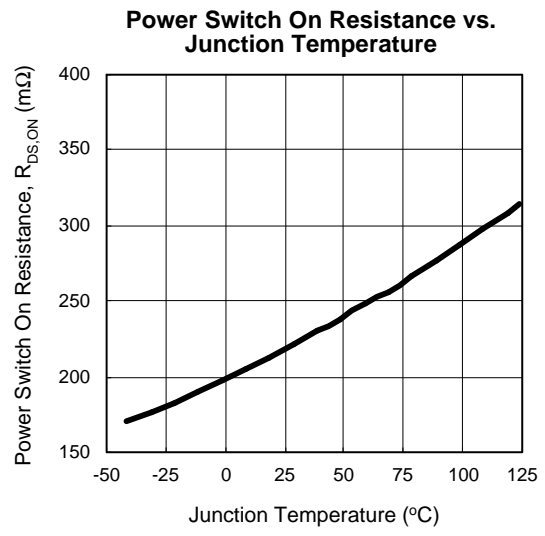
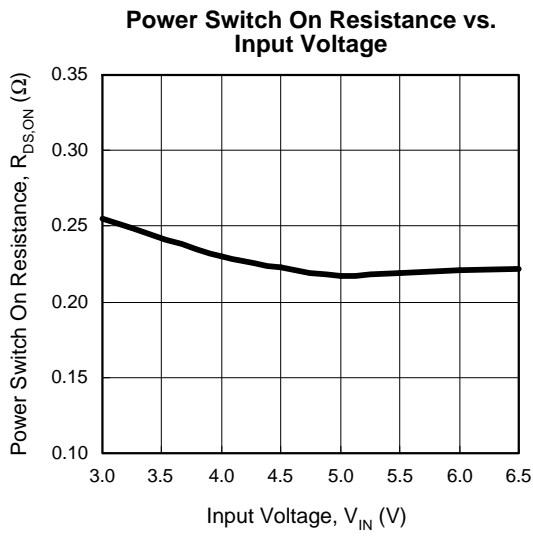

Operating Waveforms

Refer to the typical application circuit. The test condition is $V_{IN}=5V$, $T_A=25^{\circ}C$ unless otherwise specified.

Normal Power On

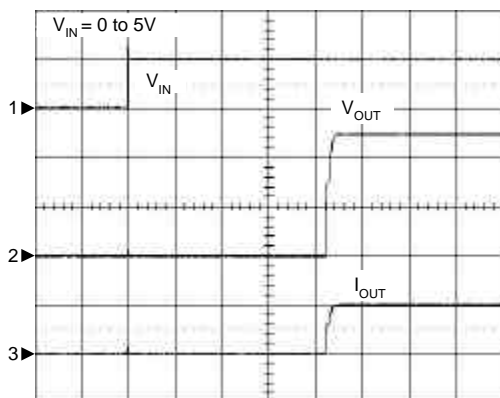

$C_{OUT}=1\mu F$, $C_{IN}=1\mu F$, $R_{OUT}=10\Omega$
 CH1: V_{IN} , 5V/Div, DC
 CH2: V_{OUT} , 2V/Div, DC
 CH3: I_{OUT} , 0.5A/Div, DC
 TIME: 2ms/Div

OVP at Power On

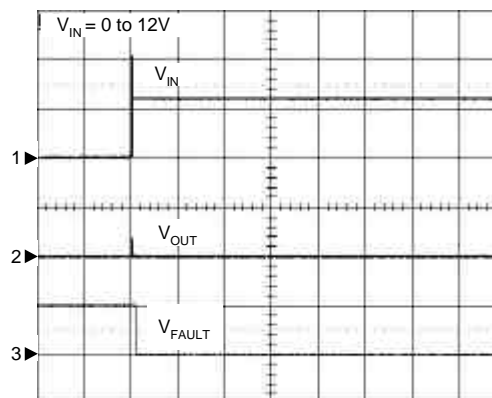

$C_{OUT}=1\mu F$, $C_{IN}=1\mu F$, $R_{OUT}=10\Omega$
 CH1: V_{IN} , 10V/Div, DC
 CH2: V_{OUT} , 2V/Div, DC
 CH3: V_{FAULT} , 5V/Div, DC
 TIME: 2ms/Div

Input Over-Voltage Protection

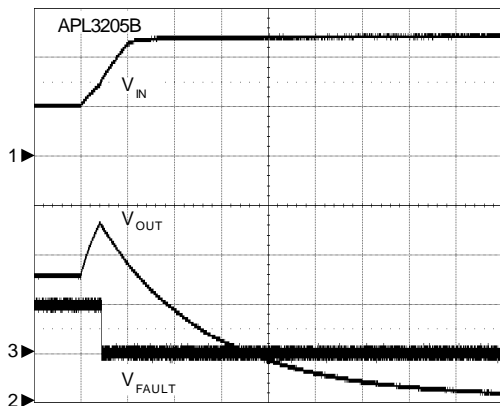

$C_{OUT}=1\mu F$, $C_{IN}=1\mu F$, $R_{OUT}=50\Omega$
 CH1: V_{IN} , 5V/Div, AC
 CH2: V_{OUT} , 2V/Div, DC
 CH3: V_{FAULT} , 5V/Div, DC
 TIME: 20 μs /Div

Input Over-Voltage Protection

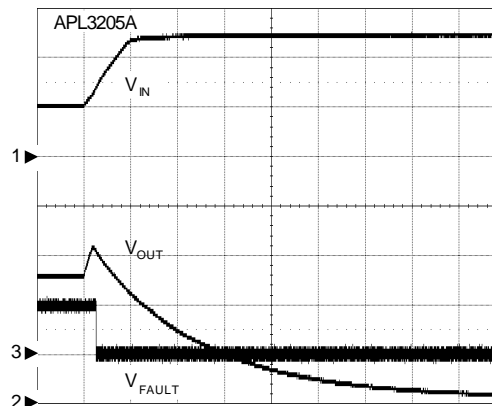

$C_{OUT}=1\mu F$, $C_{IN}=1\mu F$, $R_{OUT}=50\Omega$
 CH1: V_{IN} , 5V/Div, AC
 CH2: V_{OUT} , 2V/Div, DC
 CH3: V_{FAULT} , 5V/Div, DC
 TIME: 20 μs /Div

Operating Waveforms (Cont.)

Refer to the typical application circuit. The test condition is $V_{IN}=5V$, $T_A=25^\circ C$ unless otherwise specified.

Recovery from Input OVP

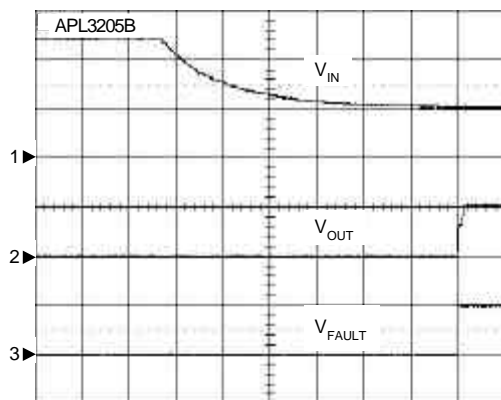

$V_{IN} = 12V$ to $5V$
 $C_{OUT} = 1\mu F$, $C_{IN} = 1\mu F$, $R_{OUT} = 50\Omega$
 CH1: V_{IN} , 5V/Div, AC
 CH2: V_{OUT} , 5V/Div, DC
 CH3: V_{FAULT} , 5V/Div, DC
 TIME: 2ms/Div

Battery Over-Voltage Protection

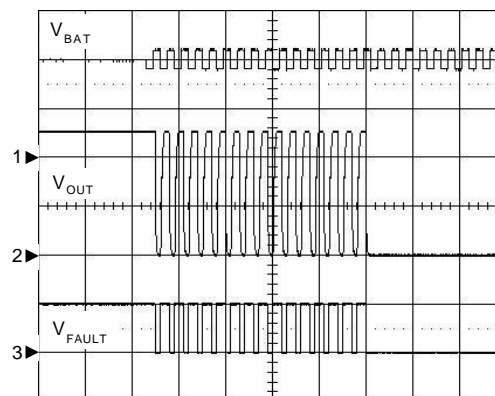

$V_{BAT} = 3.6V$ to $4.4V$ to $3.6V$, $R_{OUT} = 33.3\Omega$
 $C_{OUT} = 1\mu F$, $C_{IN} = 1\mu F$
 CH1: V_{BAT} , 2V/Div, DC
 CH2: V_{OUT} , 2V/Div, DC
 CH3: V_{FAULT} , 5V/Div, DC
 TIME: 5ms/Div

Battery Over-Voltage Protection

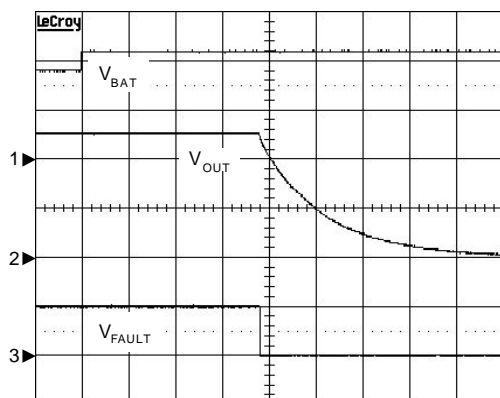

$V_{BAT} = 3.6V$ to $4.4V$, $R_{OUT} = 33.3\Omega$
 $C_{OUT} = 1\mu F$, $C_{IN} = 1\mu F$
 CH1: V_{BAT} , 2V/Div, DC
 CH2: V_{OUT} , 2V/Div, DC
 CH3: V_{FAULT} , 5V/Div, DC
 TIME: 50 μs /Div

Recovery from Battery OVP

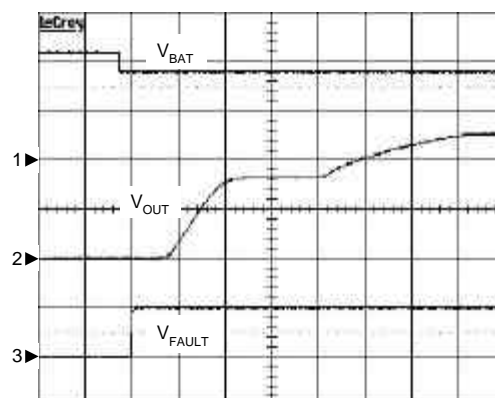

$V_{BAT} = 4.4V$ to $3.6V$, $R_{OUT} = 33.3\Omega$
 $C_{OUT} = 1\mu F$, $C_{IN} = 1\mu F$
 CH1: V_{BAT} , 2V/Div, DC
 CH2: V_{OUT} , 2V/Div, DC
 CH3: V_{FAULT} , 5V/Div, DC
 TIME: 50 μs /Div

Operating Waveforms (Cont.)

Refer to the typical application circuit. The test condition is $V_{IN}=5V$, $T_A=25^{\circ}C$ unless otherwise specified.

Over-Current Protection

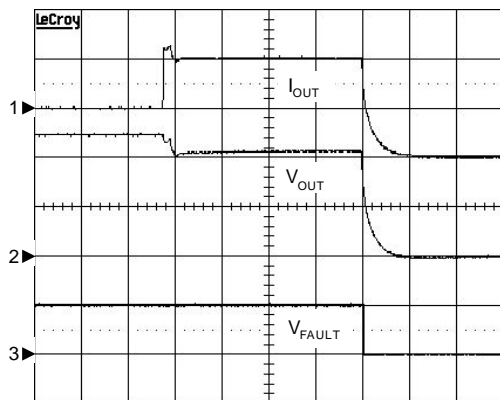

$C_{OUT}=1\mu F$, $C_{IN}=1\mu F$, $I_{OUT}=0.5A$ to $1.2A$
 CH1: I_{OUT} , 0.5A/Div, DC
 CH2: V_{OUT} , 2V/Div, DC
 CH3: V_{FAULT} , 5V/Div, DC
 TIME: 50 μs /Div

Over-Current Protection

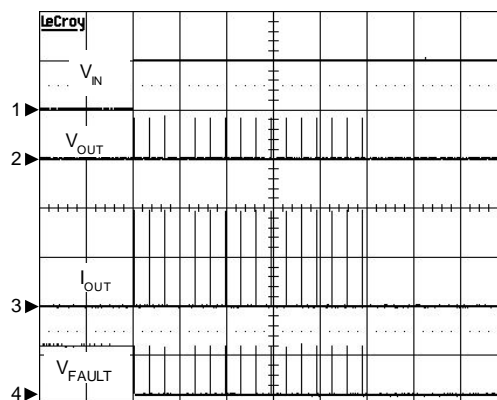

$C_{OUT}=1\mu F$, $C_{IN}=1\mu F$, $R_{OUT}=2.5\Omega$
 CH1: V_{IN} , 5V/Div, DC
 CH2: V_{OUT} , 5V/Div, DC
 CH3: I_{OUT} , 0.5A/Div, DC
 CH4: V_{FAULT} , 5V/Div, DC
 TIME: 200ms/Div

PSW Output Timing

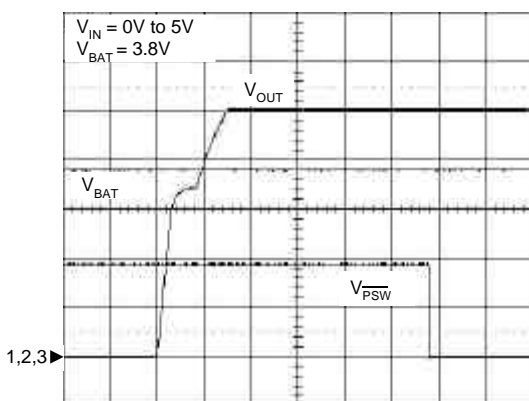

$V_{IN}=0V$ to $5V$
 $V_{BAT}=3.8V$
 $C_{OUT}=1\mu F$, $C_{IN}=1\mu F$
 CH1: V_{BAT} , 1V/Div, DC
 CH2: V_{OUT} , 1V/Div, DC
 CH3: V_{PSW} , 2V/Div, DC
 TIME: 200 μs /Div

PSW Output Timing

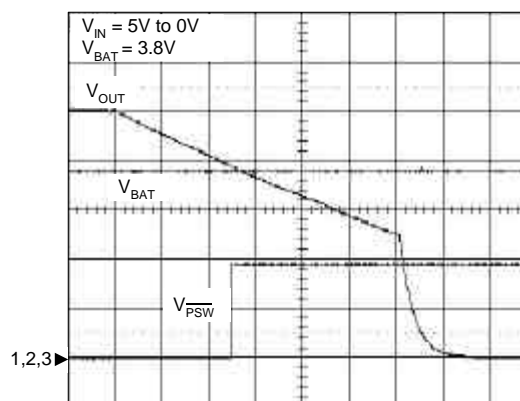

$V_{IN}=5V$ to $0V$
 $V_{BAT}=3.8V$
 $C_{OUT}=1\mu F$, $C_{IN}=1\mu F$
 CH1: V_{BAT} , 1V/Div, DC
 CH2: V_{OUT} , 1V/Div, DC
 CH3: V_{PSW} , 2V/Div, DC
 TIME: 5ms/Div

Pin Description

PIN		FUNCTION
NO.	NAME	
1	IN	Power Supply Input.
2	GND	Ground.
3	$\overline{\text{PSW}}$	$\overline{\text{PSW}}$ is an active high output that drives the external PMOS (see Application Circuit).
4	$\overline{\text{FAULT}}$	Fault Indication Pin. This pin goes low when input OVP, OCP, or battery OVP is detected.
5	$\overline{\text{EN}}$	Enable Input. Pull this pin to high to disable the device and pull this pin to low to enable device.
6	BAT	Battery OVP Sense Pin. Connect to positive terminal of battery through a resistor.
7	ILIM	Over-current Protection Setting Pin. Connect a resistor to the GND to set the over-current threshold.
8	OUT	Output Voltage Pin. The output voltage follows the input voltage when no fault is detected.
-	EP	Exposed Thermal Pad. Must be electrically connected to the GND pin.

Block Diagram

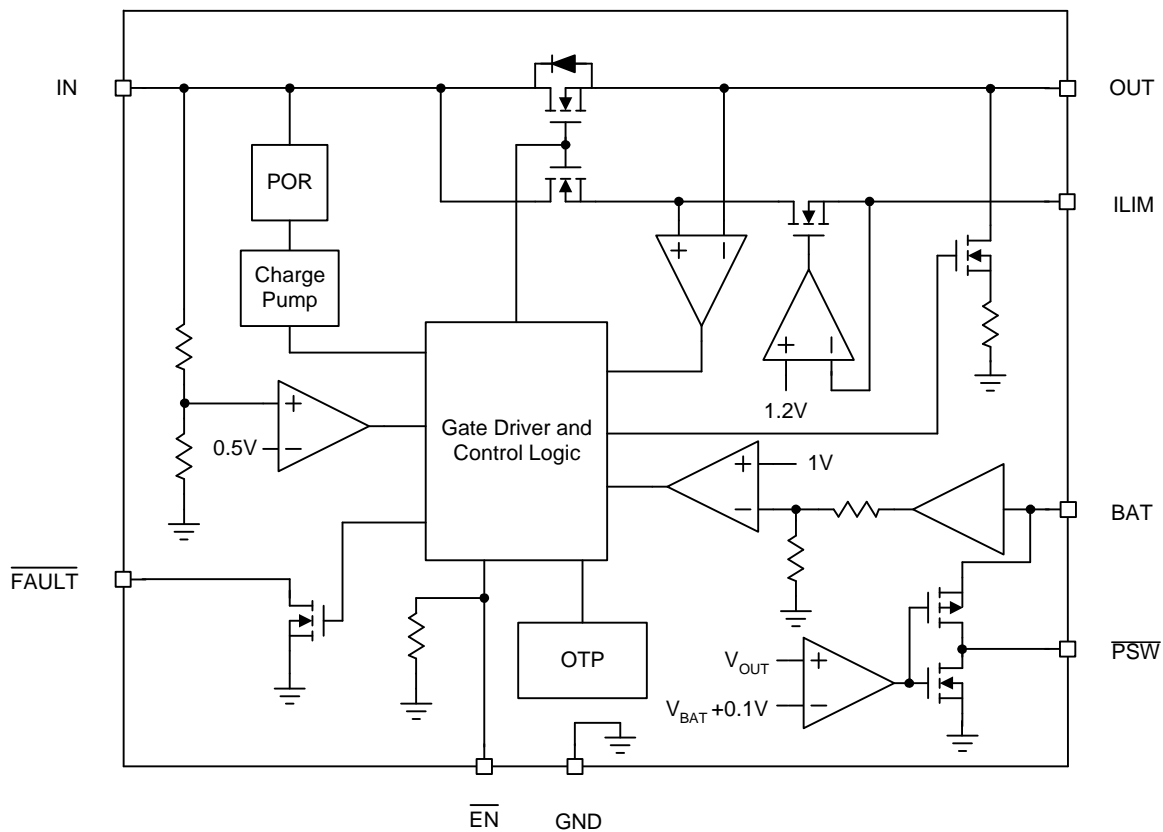

Typical Application Circuit

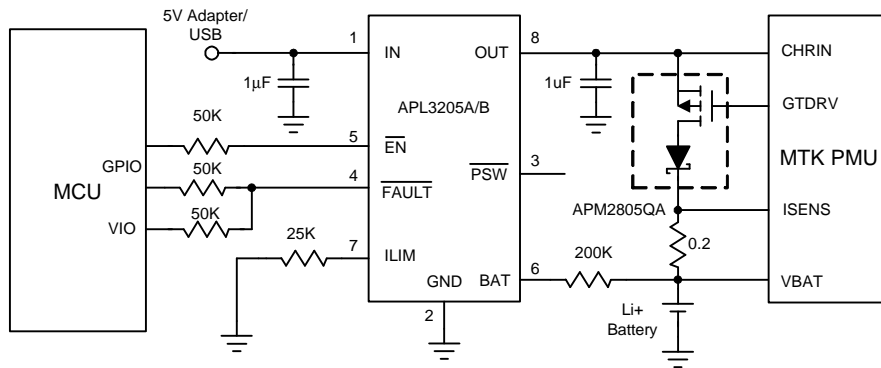

Figure 1. The Typical Protection Circuit for Charger Systems.

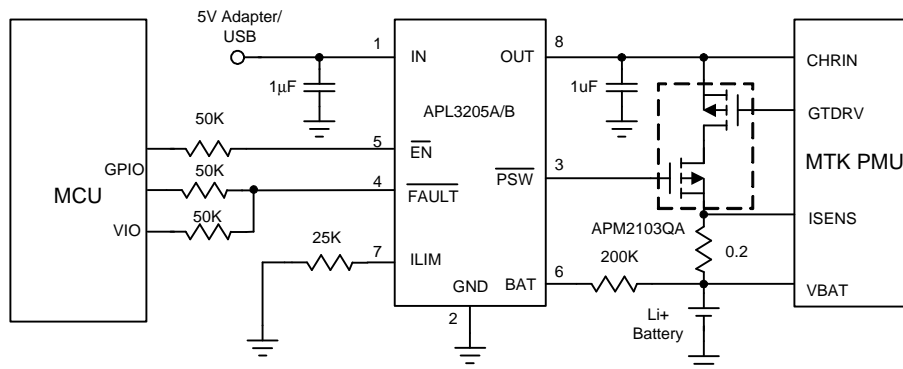

Figure 2. Use the PSW pin to drive an external P-Channel MOSFET T for Charger Systems.

Function Description

Power-Up

The APL3205A/B have a built-in power-on-reset circuit to keep the output shutting off until internal circuitry is operating properly. The POR circuit has hysteresis and a de-glitch feature, therefore, it will typically ignore undershoot transients on the input. When input voltage exceeds the POR threshold and after 8ms blanking time, the output voltage starts a soft-start to reduce the inrush current.

Input Over-Voltage Protection (OVP)

The input voltage is monitored by the internal OVP circuit. When the input voltage rises above the input OVP threshold, the internal FET will be turned off within 1 μ s to protect connected system on OUT pin. When the input voltage returns below the input OVP threshold minus the hysteresis, the FET is turned on again after 8ms recovery time. The input OVP circuit has a 200mV hysteresis and a recovery time of $T_{ON(OVP)}$ to provide noise immunity against transient conditions.

Over-Current Protection (OCP)

The output current is monitored by the internal OCP circuit. When the output current reaches the OCP threshold, the device limits the output current at OCP threshold level. If the OCP condition continues for a blanking time of $T_{B(OCP)}$, the internal power FET is turned off. After the recovery time of $T_{ON(OCP)}$, the FET will be turned on again and the output current is monitored again. The APL3205A/B have a built-in counter. When the total count of OCP fault reaches 16, the FET is turned off permanently, requiring either a V_{IN} POR or \overline{EN} re-enable again to restart. The OCP threshold is programmed by a resistor R_{ILIM} connected from ILIM pin to the GND. The OCP threshold is calculated by the following equation:

$$I_{OCP} = \frac{K_{ILIM}}{R_{ILIM}}$$

where

$$K_{ILIM} = 25000A\Omega$$

Battery Over-Voltage-Protection

The APL3205A/B monitor the BAT pin voltage for battery over-voltage protection. The battery OVP threshold is internally set to 4.35V. When the BAT pin voltage exceeds the battery OVP threshold for a blanking time of $T_{B(BOVP)}$,

the internal power FET is turned off. When the BP voltage returns below the battery OVP threshold minus the hysteresis, the FET is turned on again. The APL3205A/B have a built-in counter. When the total count of battery OVP fault reaches 16, the FET is turned off permanently, requiring either a V_{IN} POR or \overline{EN} re-enable again to restart.

Over-Temperature Protection

When the junction temperature exceeds 140°C, the internal thermal sense circuit turns off the power FET and allows the device to cool down. When the device's junction temperature cools by 20°C, the internal thermal sense circuit will enable the device, resulting in a pulsed output during continuous thermal protection. Thermal protection is designed to protect the IC in the event of over temperature conditions. For normal operation, the junction temperature cannot exceed $T_J = +125^\circ\text{C}$.

\overline{FAULT} Output

The APL3205A/B provide an open-drain output to indicate that a fault has occurred. When any of input OVP, OCP, battery OVP, is detected, the \overline{FAULT} goes low to indicate that a fault has occurred. Since the \overline{FAULT} pin is an open-drain output, connecting a resistor to a pull high voltage is necessary.

Enable/Shutdown

Pulling the \overline{EN} pin voltage above 1.4V disables the device and pulling \overline{EN} pin voltage below 0.4V enables the device. The \overline{EN} pin has an internal pull-down resistor and can be left floating. When the IC is latched off due to the total count of OCP or battery OVP reaches 16, disable and re-enable the device with the \overline{EN} pin can clear the counter.

\overline{PSW} Output

The APL3205A/B provide an active high output to drive the external P-channel MOSFET. When $V_{OUT} > V_{BAT} + 100\text{mV}$, the \overline{PSW} pin is pulled low, and turns on the external P-channel MOSFET for battery charge. When $V_{OUT} < V_{BAT} + 50\text{mV}$, the \overline{PSW} pin is pulled high, and turns off the external P-channel MOSFET, which prevents the battery voltage from supplying to OUT pin and IN pin (see Application Circuit).

Function Description (Cont.)

Powering an Accessory Device

In some applications, such as USB On-The-Go, users need to power an accessory device by using the portable device's battery through the jack holes of AC adapter. The APL3205 provide reverse current flow path from OUT to IN. If $V_{OUT} > V_{POR} + 0.7V$, FET Q1 is turned on, and the reverse current does not flow through the diode but through Q1. Q1 will then remain ON as long as $V_{OUT} > V_{POR} - V_{POR_HYS} + R_{DS_ON} * I_{SUPPLY}$. Within this voltage range, the reverse current capability is the same as the forward capability, 1.5A. It should be noted that there is no overcurrent protection in this direction.

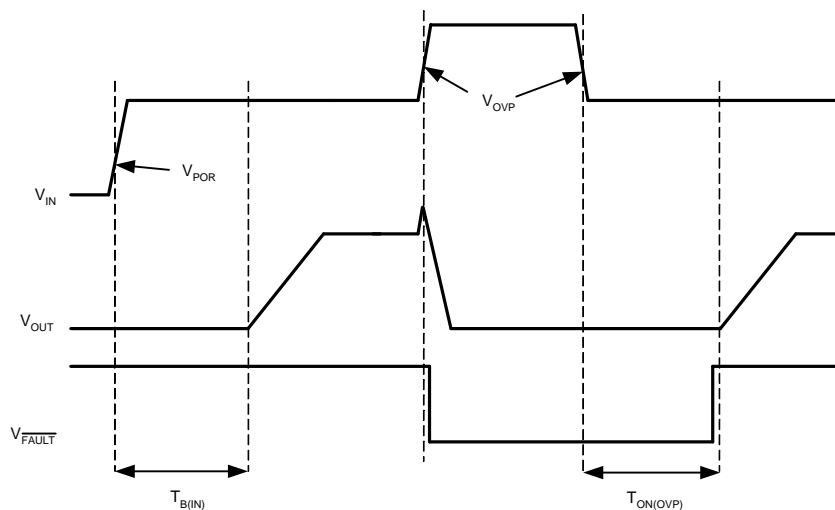
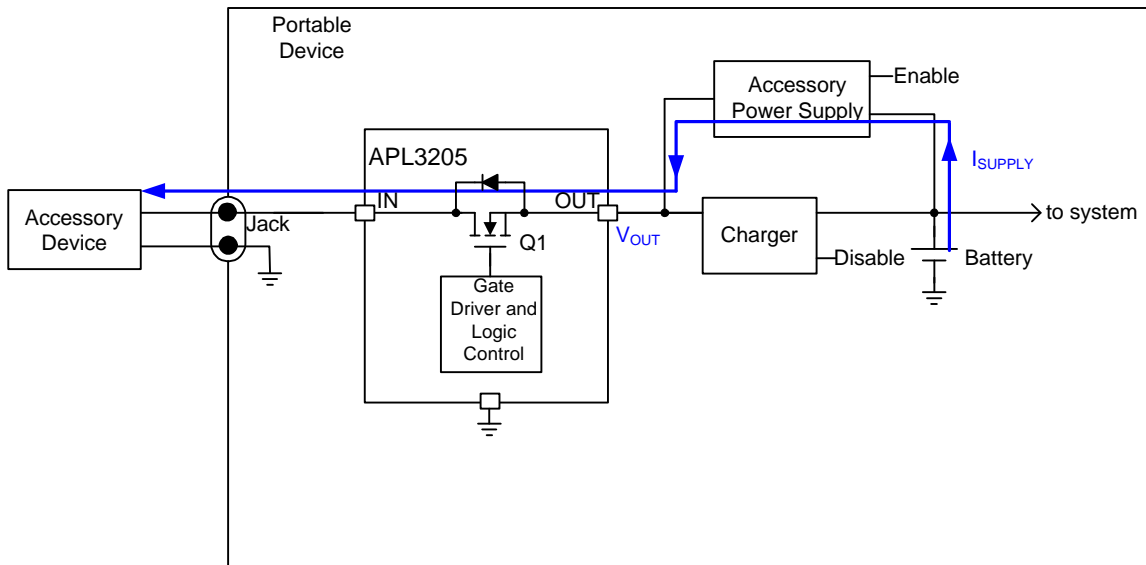

Figure3. OVP Timing Chart

Function Description (Cont.)

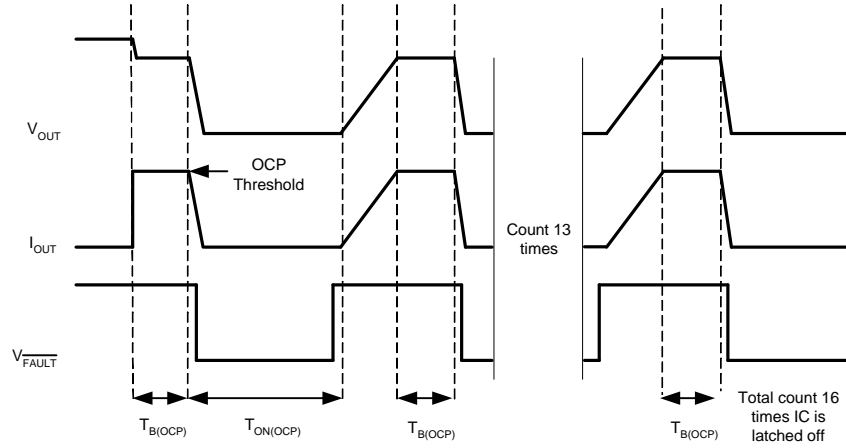

Figure 4. OCP Timing Chart

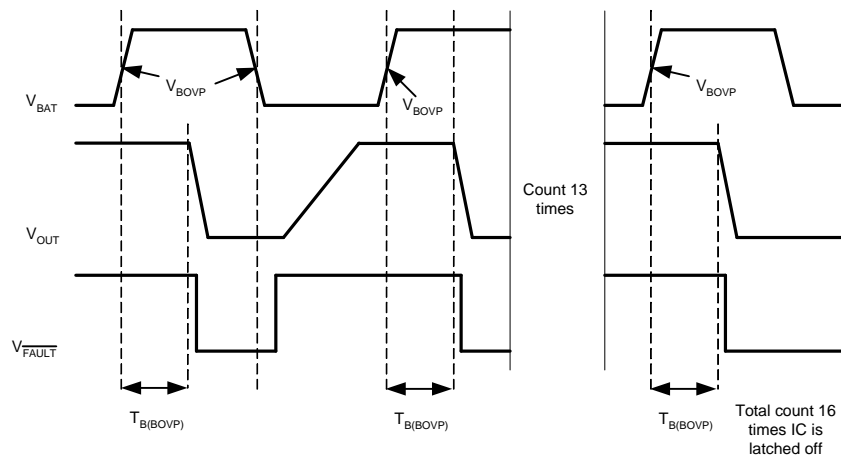

Figure 5. Battery OVP Timing Chart

Application Information

R_{BAT} Selection

Connect the BAT pin to the positive terminal of battery through a resistor R_{BAT} for battery OVP function. The R_{BAT} limits the current flowing from BAT to battery in case of BAT pin is shortened to VIN pin under a failure mode. The recommended value of R_{BAT} is 100kΩ. In the worse case of an IC failure, the current flowing from the BAT pin to the battery is:

$$(30V-3V)/100k\Omega = 270\mu A$$

where the 30V is the maximum IN voltage and the 3V is the minimum battery voltage. The current is so small that can be absorbed by the charger system.

The disadvantage with the large R_{BAT} is that the error of the battery OVP threshold will be increased. The additional error is the voltage drop across the R_{BAT} because of the BAT bias current. When R_{BAT} is 100kΩ, the worse-case additional error is 100kΩ×20nA=2mV, which is acceptable in most applications.

R_{EN} Selection

For the same reason as the BAT pin case, the EN pin should be connected to the MCU GPIO pin through a resistor. The value of the R_{EN} is dependent on the IO voltage of the MCU.

Since the IO voltage is divided by R_{EN} and \overline{EN} internal pull low resistor for \overline{EN} voltage. It has to be ensured that the \overline{EN} voltage is above the \overline{EN} logic high voltage when the GPIO output of the MCU is high.

\overline{FAULT} Output

Since the FAULT pin is an open-drain output, connecting a resistor R_{UP} to a pull high voltage is necessary. It is also recommended that connect the \overline{FAULT} to the MCU GPIO through a resistor R_{FAULT}. The R_{FAULT} prevents damage to the MCU under a failure mode. The recommended value of the resistors should be between 10kΩ and 100kΩ.

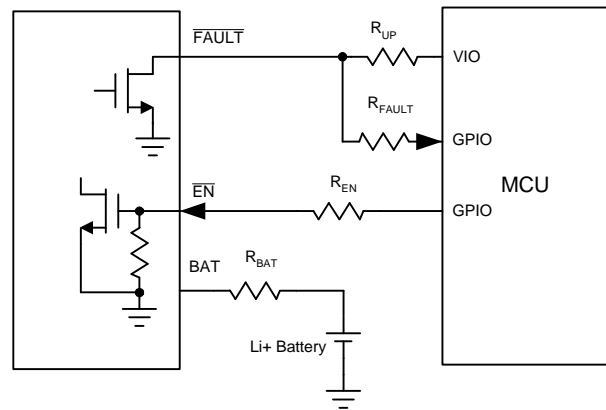

Figure 6. R_{UP}, R_{FAULT}, R_{EN} and R_{BAT}

Capacitor Selection

The input capacitor is for decoupling and prevents the input voltage from overshooting to dangerous levels. In the AC adapter hot plug-in applications or load current step-down transient, the input voltage has a transient spike due to the parasitic inductance of the input cable. A 25V, X5R, dielectric ceramic capacitor with a value between 1μF and 4.7μF placed close to the IN pin is recommended.

The output capacitor is for output voltage decoupling, and also can be as the input capacitor of the charging circuit. At least, a 1μF, 10V, X5R capacitor is recommended.

Layout Consideration

In some failure modes, a high voltage may be applied to the device. Make sure that the clearance constraint of the PCB layout must satisfy the design rule for high voltage. The exposed pad of the TDFN2x2-8 performs the function of channeling heat away. It is recommended that connect the exposed pad to a large copper ground plane on the backside of the circuit board through several thermal vias to improve heat dissipation.

The input and output capacitors should be placed close to the IC. R_{ILIM} also should be placed close to the IC.

The high current traces like input trace and output trace must be wide and short.

Package Information

TDFN2x2-8

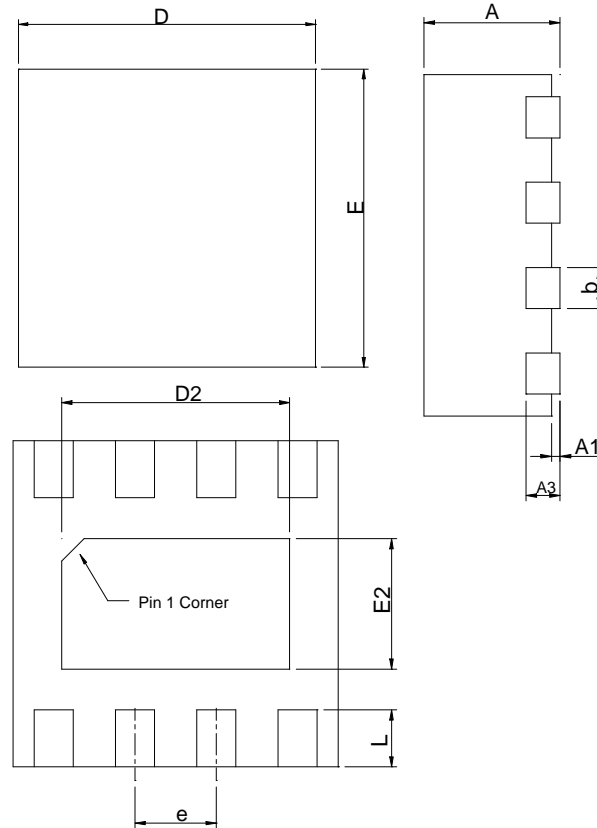

SYMBOL	TDFN2x2-8			
	MILLIMETERS		INCHES	
	MIN.	MAX.	MIN.	MAX.
A	0.70	0.80	0.028	0.031
A1	0.00	0.05	0.000	0.002
A3	0.20 REF		0.008 REF	
b	0.18	0.30	0.007	0.012
D	1.90	2.10	0.075	0.083
D2	1.00	1.60	0.039	0.063
E	1.90	2.10	0.075	0.083
E2	0.60	1.00	0.024	0.039
e	0.50 BSC		0.020 BSC	
L	0.30	0.45	0.012	0.018

Note : 1. Follow from JEDEC MO-229 WCCD-3.

Carrier Tape & Reel Dimensions

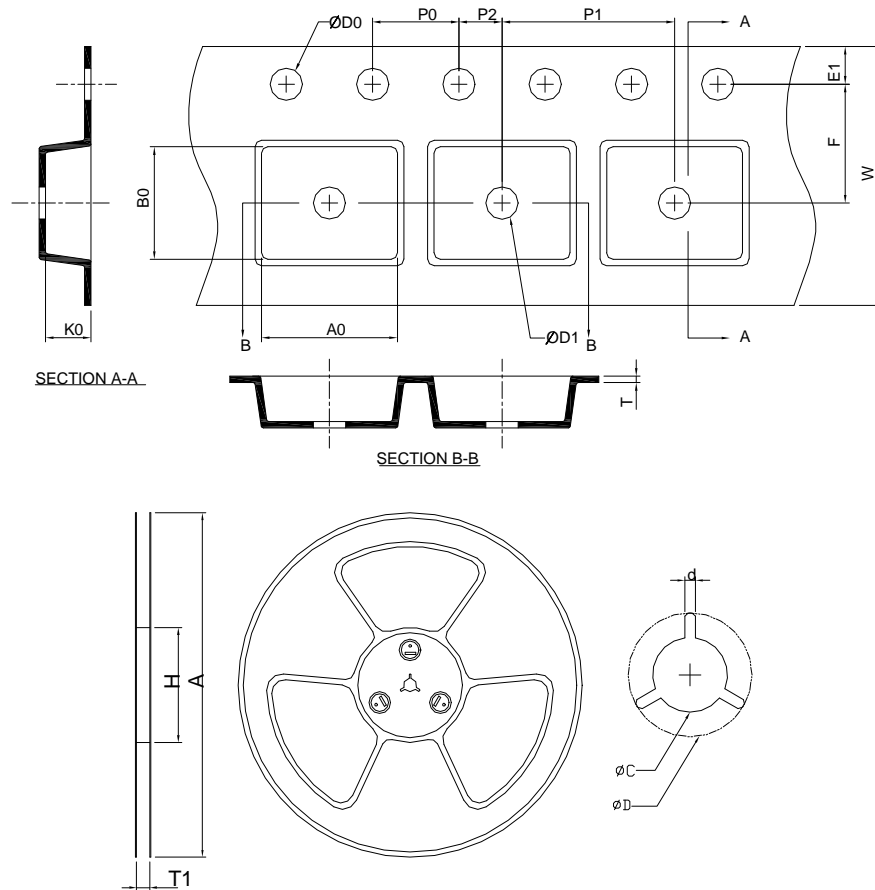

Application	A	H	T1	C	d	D	W	E1	F
TDFN2x2-8	178.0 ±0.00	50 MIN.	8.4+2.00 -0.00	13.0+0.50 -0.20	1.5 MIN.	20.2 MIN.	8.0 ±0.20	1.75 ±0.10	3.50 ±0.05
	P0	P1	P2	D0	D1	T	A0	B0	K0
	4.0 ±0.10	4.0 ±0.10	2.0 ±0.05	1.5+0.10 -0.00	1.5 MIN.	0.6+0.00 -0.4	3.35 MIN	3.35 MIN	1.30 ±0.20

(mm)

Devices Per Unit

Package Type	Unit	Quantity
TDFN2x2-8	Tape & Reel	3000

Taping Direction Information

TDFN2x2-8

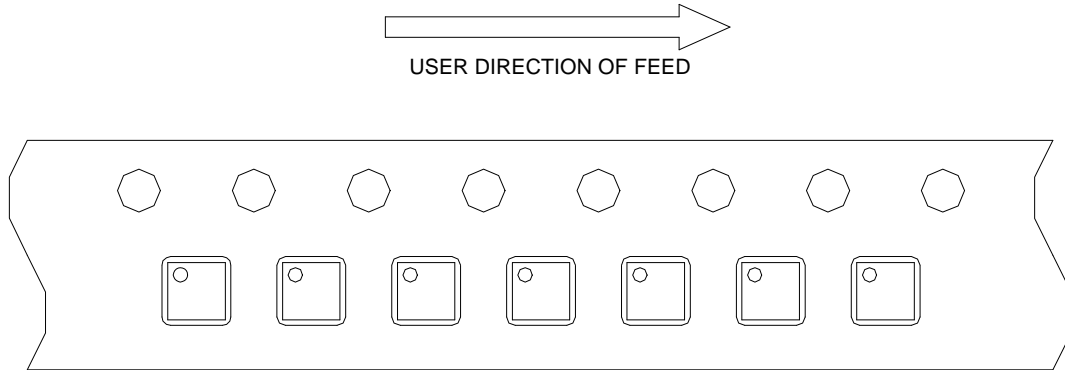

Classification Profile

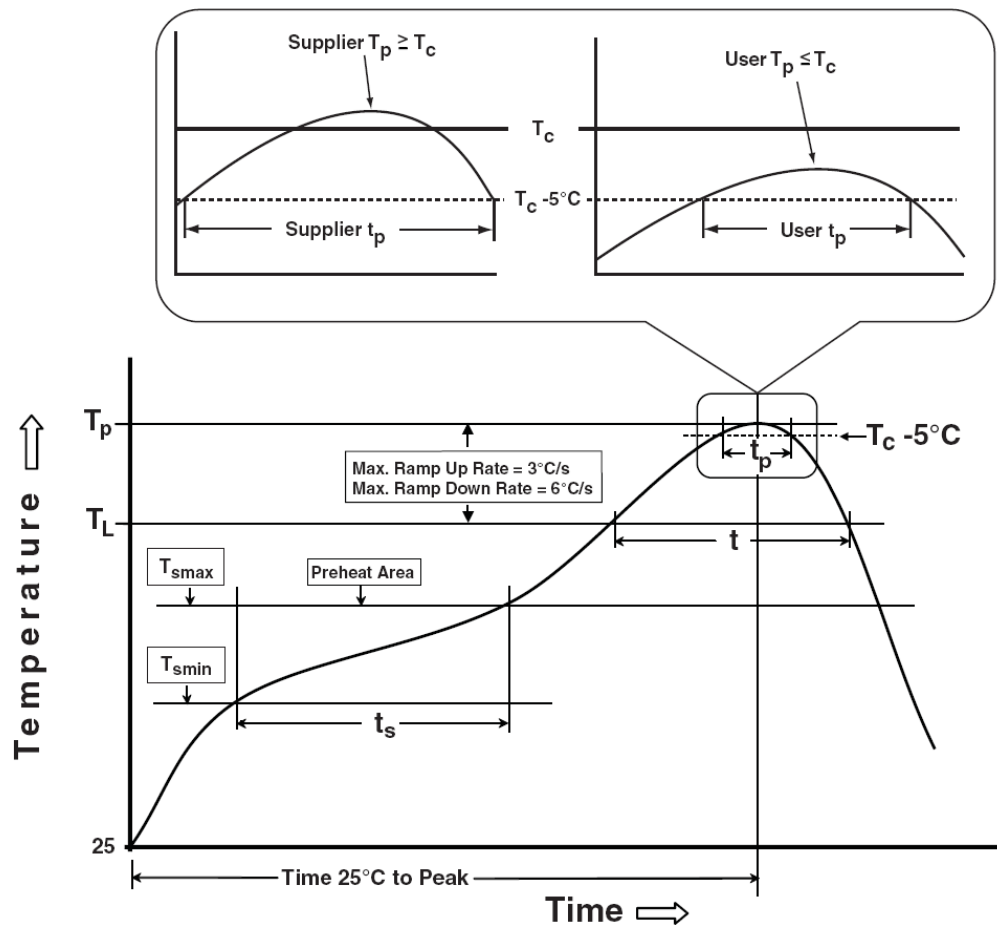

Classification Reflow Profiles

Profile Feature	Sn-Pb Eutectic Assembly	Pb-Free Assembly
Preheat & Soak		
Temperature min (T_{smin})	100 °C	150 °C
Temperature max (T_{smax})	150 °C	200 °C
Time (T_{smin} to T_{smax}) (t_s)	60-120 seconds	60-120 seconds
Average ramp-up rate (T_{smax} to T_p)	3 °C/second max.	3°C/second max.
Liquidous temperature (T_L)	183 °C	217 °C
Time at liquidous (t_L)	60-150 seconds	60-150 seconds
Peak package body Temperature (T_p)*	See Classification Temp in table 1	See Classification Temp in table 2
Time (t_p)** within 5°C of the specified classification temperature (T_c)	20** seconds	30** seconds
Average ramp-down rate (T_p to T_{smax})	6 °C/second max.	6 °C/second max.
Time 25°C to peak temperature	6 minutes max.	8 minutes max.
* Tolerance for peak profile Temperature (T_p) is defined as a supplier minimum and a user maximum.		
** Tolerance for time at peak profile temperature (t_p) is defined as a supplier minimum and a user maximum.		

Table 1. SnPb Eutectic Process – Classification Temperatures (T_c)

Package Thickness	Volume mm ³ <350	Volume mm ³ ≥350
<2.5 mm	235 °C	220 °C
≥2.5 mm	220 °C	220 °C

Table 2. Pb-free Process – Classification Temperatures (T_c)

Package Thickness	Volume mm ³ <350	Volume mm ³ 350-2000	Volume mm ³ >2000
<1.6 mm	260 °C	260 °C	260 °C
1.6 mm – 2.5 mm	260 °C	250 °C	245 °C
≥2.5 mm	250 °C	245 °C	245 °C

Reliability Test Program

Test item	Method	Description
SOLDERABILITY	JESD-22, B102	5 Sec, 245°C
HOLT	JESD-22, A108	1000 Hrs, Bias @ 125°C
PCT	JESD-22, A102	168 Hrs, 100%RH, 2atm, 121°C
TCT	JESD-22, A104	500 Cycles, -65°C~150°C
ESD	MIL-STD-883-3015.7	VHBM 2KV, VMM 200V
Latch-Up	JESD 78	10ms, 1 _{tr} 100mA

Customer Service

Anpec Electronics Corp.

Head Office :

No.6, Dusing 1st Road, SBIP,
Hsin-Chu, Taiwan, R.O.C.
Tel : 886-3-5642000
Fax : 886-3-5642050

Taipei Branch :

2F, No. 11, Lane 218, Sec 2 Jhongsing Rd.,
Sindian City, Taipei County 23146, Taiwan
Tel : 886-2-2910-3838
Fax : 886-2-2917-3838