

SX-4417

Non-Contacting Steering Sensor



Features:

- Dual torque and multi-turn position outputs in one compact package
- Redundant outputs for full diagnostics
- Lead-free
- RoHS 2 compliant

Applications:

- Electric power steering systems

Electrical

Torque operating input voltage range	4.5 to 5.5 VDC
Torque input voltage absolute limits	-14.5 to +30 VDC
Torque supply current	10 to 20 mA
Torque sensed angle	±5°
Torque signal linearity	±3%
Torque hysteresis	±1.3%
Torque signal microgradient (over travel increment of 0.4°)	3.2% V_{in} ±1.0% V_{in}
Torque wobble	40 mV
Position operating input voltage range	4.5 to 5.5 VDC
Position input voltage absolute limits	-0.3 to +6.5 VDC
Position supply current	25 to 50 mA
Position signal linearity	±1%
Position hysteresis	±0.25%
Position signal microgradient (over travel increment of 2°)	1.11% V_{in} ±0.34% V_{in}

Mechanical

Torque mechanical travel	Continuous
Position mechanical travel	Continuous
Turning torque (position rotor to housing)	0.02 NM maximum
Weight	101 gram maximum

General Note

TT Electronics reserves the right to make changes in product specification without notice or liability. All information is subject to TT Electronics' own data and is considered accurate at time of going to print.

BI Technologies
4200 Bonita Place, Fullerton, CA 92835 | Ph: +1 714 447 2300
www.bitechnologies.com | www.ttelectronics.com

Environmental

Operating temperature range	-40°C to +85°C
Vibration	10 to 55 Hz with 1 mm P-P constant displacement, 120 hours each of 3 planes
Torque rotational life	Infinite (non-contacting)
Position rotational life	1 million revolutions
Storage temperature range	-55°C to +105°C

Output Charts

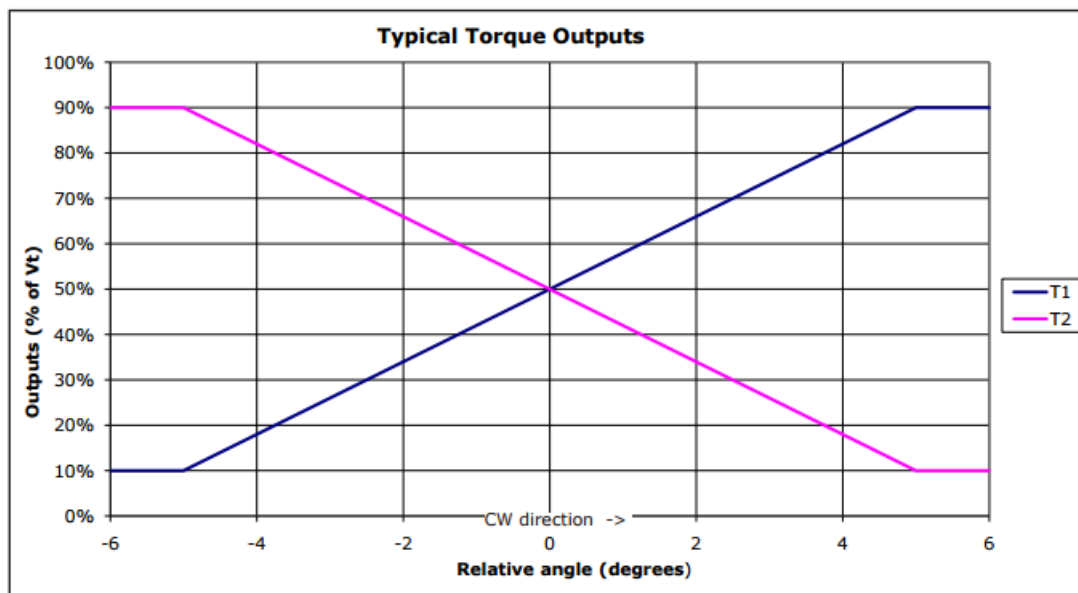
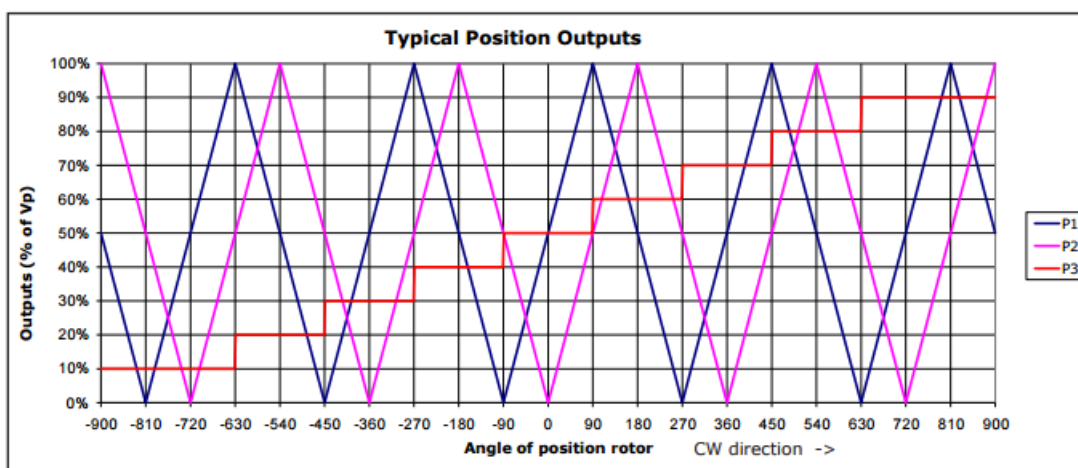

Different output signals can be easily configured by BI. Contact factory for details.

General Note

TT Electronics reserves the right to make changes in product specification without notice or liability. All information is subject to TT Electronics' own data and is considered accurate at time of going to print.

BI Technologies
 4200 Bonita Place, Fullerton, CA 92835 | Ph: +1 714 447 2300
www.bitechnologies.com | www.ttelectronics.com

SX-4417

Non-Contacting Steering Sensor



Outline Drawing

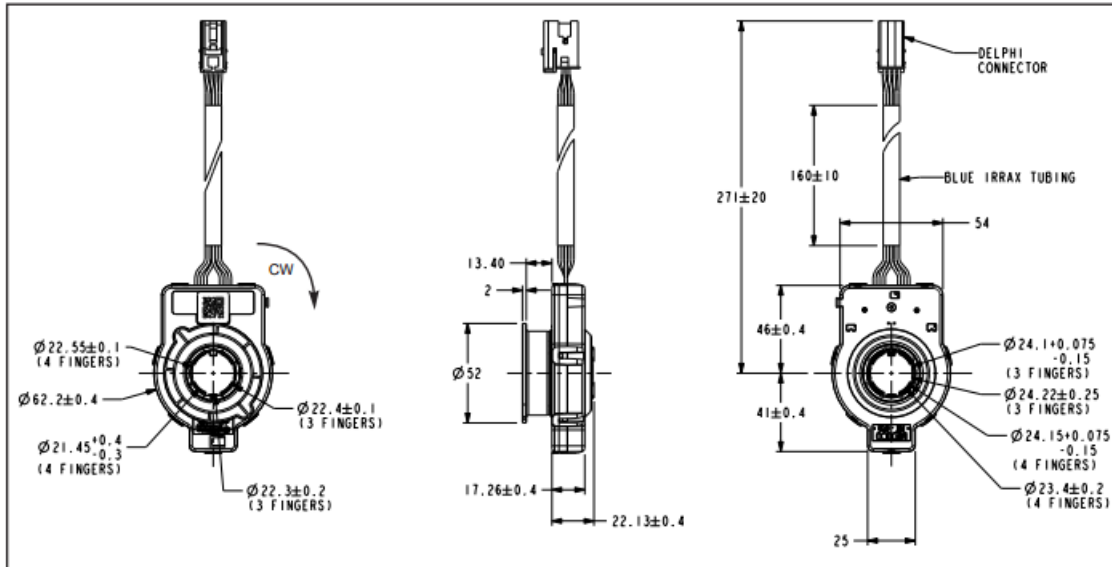

Dimensions in mm
Detailed outline drawing available on request

Pinouts

PIN No.	SIGNAL	WIRE COLOR
1	P3	YELLOW
2	P1	BROWN
3	VT	RED
4	T2	PURPLE
5	VP	ORANGE
6	P2	WHITE
7	GND	BLACK
8	T1	BLUE

DELPHI CONNECTOR 15406142
WIRE INSERTION END VIEW

Barcode Label



**Micro QR M4
symbology**

**Content not human readable:
4417 E YY DDD T SSSS**

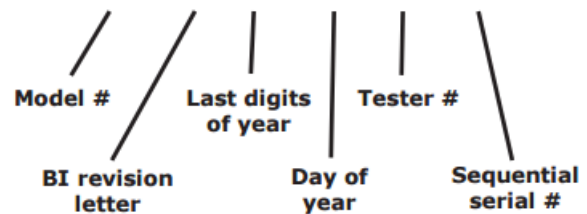

General Note

TT Electronics reserves the right to make changes in product specification without notice or liability. All information is subject to TT Electronics' own data and is considered accurate at time of going to print.

BI Technologies
4200 Bonita Place, Fullerton, CA 92835 | Ph: +1 714 447 2300
www.bitechnologies.com | www.ttelectronics.com