

| REV | CHANGE | DATE     | DRN | CHK |
|-----|--------|----------|-----|-----|
|     | Drawn  | 02/08/17 | SJ  | T   |

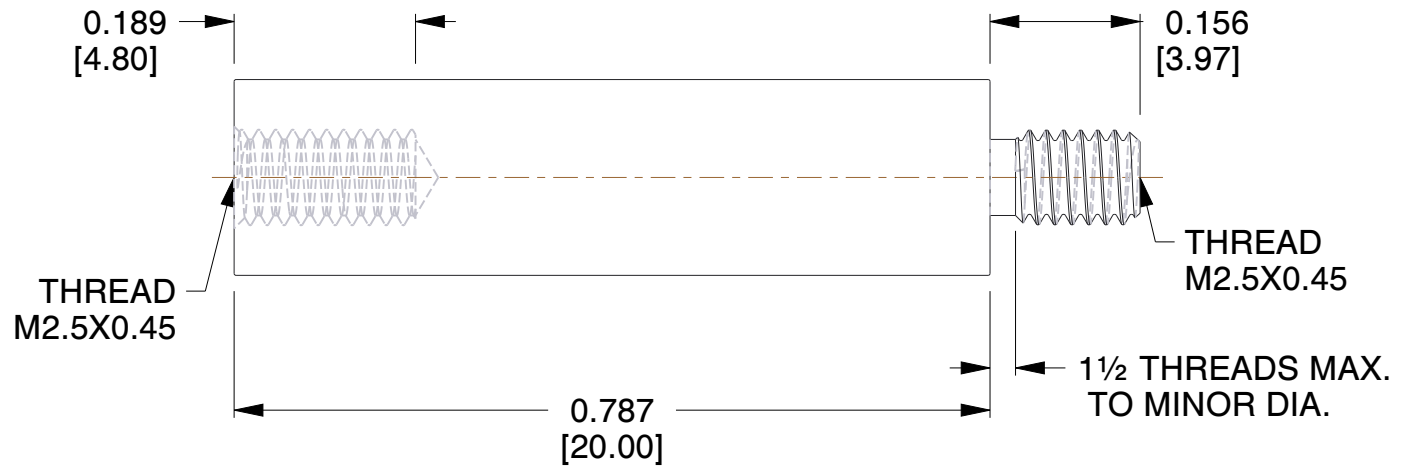
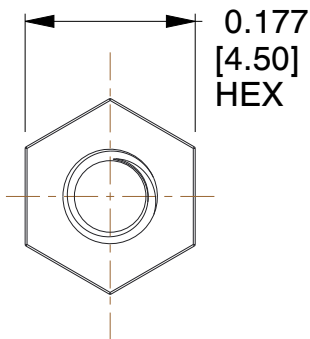
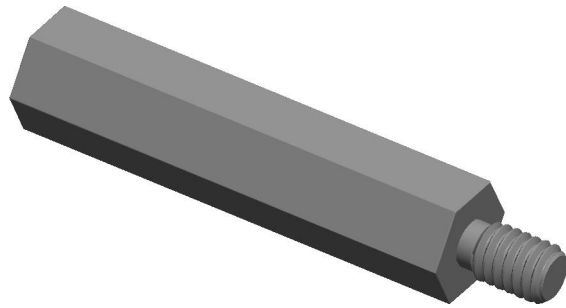

**NOTES:**

1. Material : Stainless Steel
2. Finish : No Plate
3. ASME Y14.5M - 2009
4. All Drawing Dimensions are in Inches [mm]
5. Unless otherwise specified; Edge Breaks, Radii or Countersinks 0.005-0.015

| COMPONENT                        | STANDOFFS    |
|----------------------------------|--------------|
| <b>M2115-2545-SS</b>             | <b>SCALE</b> |
|                                  | 5.00         |
|                                  | <b>SHEET</b> |
| 4.5 MM HEX MALE-FEMALE STANDOFFS | 1 of 1       |



95 Silvermine Rd., Seymour CT 06483  
Tel: 203-888-2133, Fax: 203-888-9860

This Drawing is the Property of RAF.  
It contains confidential, proprietary information that is RAF property. Do not disclose to or duplicate for others except as authorized by RAF.

**TOLERANCES**  
ALL DIMENSIONS ARE INCHES (UNLESS OTHERWISE SPECIFIED)  
**METALLIC**  
LENGTHS <math>\le 6</math> INCHES  $\pm 0.005$   
LENGTH > 6 INCHES  $\pm 0.010$   
DIAMETERS:  $\pm 0.005$   
**NON-METALLIC**  
LENGTH:  $\pm 0.010$  DIAMETERS:  $\pm 0.010$   
**INTERNAL THREADS:**  
MINIMUM THREAD DEPTH