

Monolithic HMIC Integrated Dual Bias Network 18 - 40 GHz

MA4BN1840-2

Features

- Broad Bandwidth Specified for 18 to 40 GHz
- Useable from 15 GHz to 50 GHz
- Extremely Low Insertion Loss
- High RF-DC Isolation
- Rugged, Fully Monolithic, Glass Encapsulated Construction

Description

The MA4BN1840-2 device is a fully monolithic broadband bias network utilizing M/A-COM's HMIC™ (Heterolithic Microwave Integrated Circuit) Process, US Patent 5,268,310. This process allows the incorporation of silicon pedestals that form vias by imbedding them in low loss, low dispersion glass. By using small spacing between elements, this combination of silicon and glass gives HMIC devices low loss and high performance with exceptional repeatability through millimeter frequencies.

Large bond pads facilitate the use of low inductance ribbon bonds, while gold backside metalization allows for manual or automatic die attach via 80Au/20Sn or Sn62/Pb36/Ag2 solders or electrically conductive silver epoxy.

Applications

The MA4BN1840-2 millimeter frequency bias network is suitable for D.C. biasing PIN Diode control circuits as a RF-DC de-coupling network, a conventional Bias Tee, and as a D.C. Return network. The device can also be used as a bi-directional re-active coupler for schottky detector circuits. D.C. currents up to 150 mA and D.C. voltages up to 50 V may be used

MA4BN1840-2 Chip Layout

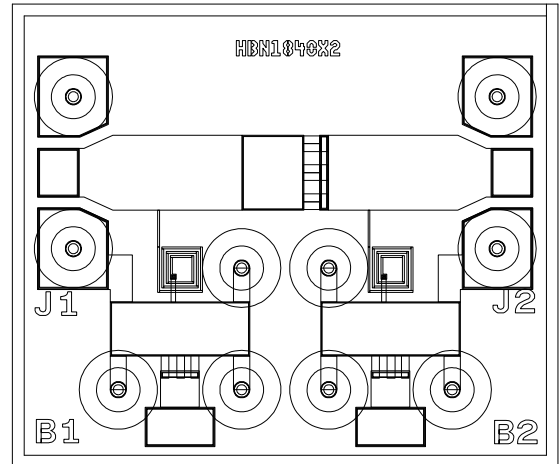

Absolute Maximum Ratings¹

@ TA = +25 °C

(Unless otherwise specified)

Parameter	Value
Operating Temperature	-65 °C to +125 °C
Storage Temperature	-65 °C to +150 °C
Die Attach Temperature	320 °C for 20 sec
RF C.W. Incident Power	10 Watts
D.C. Bias Current	+/- 150 mA
D.C. Bias Voltage	+/- 50 V

1. Exceeding any of these values may result in permanent damage

**Electrical Specifications @ T_A = +25 °C
(On-Wafer Measurements)**

Parameter	Frequency	Minimum Value	Average Value	Maximum Value	Units
Insertion Loss	18-40 GHz	-	0.25	0.4	dB
RF - DC Isolation	18-40 GHz	30	35	-	dB
Input Return Loss	18-40 GHz	15	17	-	dB
Output Return Loss	18-40 GHz	15	17	-	dB

RF Performance (On Wafer Measurements of Several Devices)

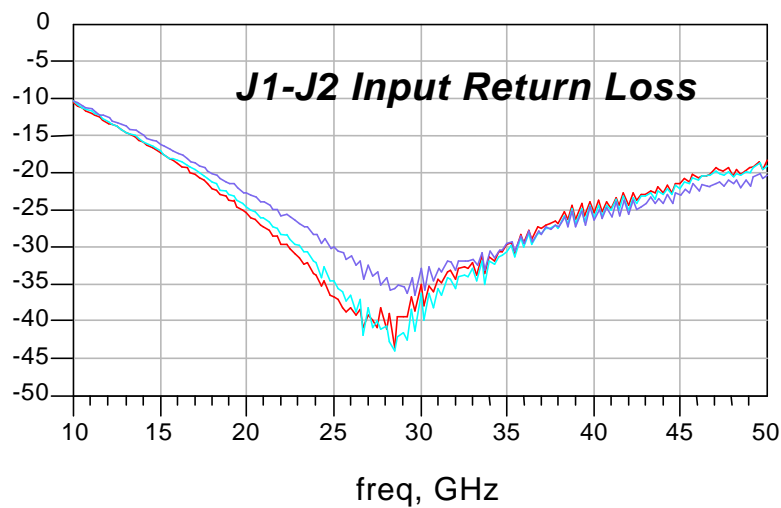
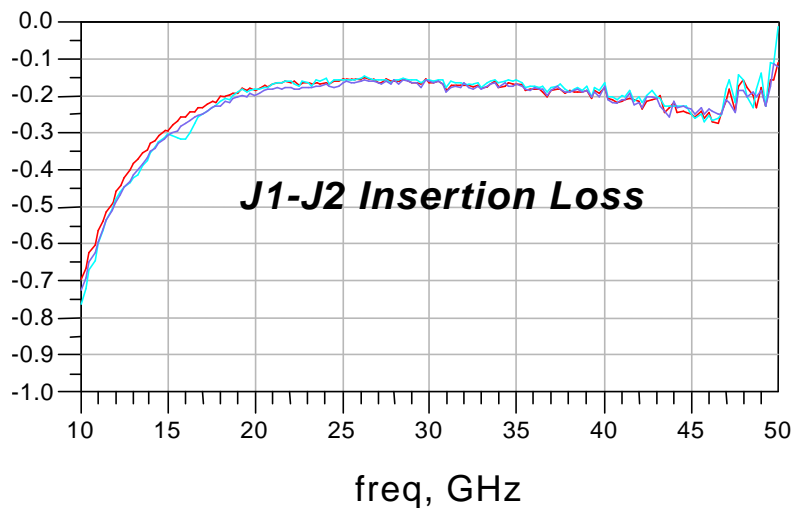

M/A-COM Inc. and its affiliates reserve the right to make changes to the product(s) or information contained herein without notice.

Visit www.macom.com for additional data sheets and product information.

- North America: Tel. (800) 366-2266
- Asia/Pacific: Tel. +81-44-844-8296, Fax +81-44-844-8298
- Europe: Tel. +44 (1908) 574 200, Fax+44 (1908) 574 300

RF Performance (On Wafer Measurements of Several Devices)

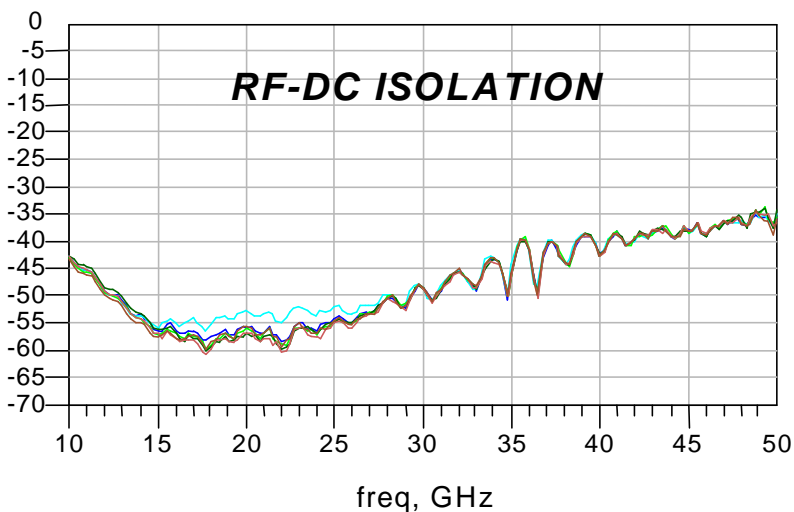
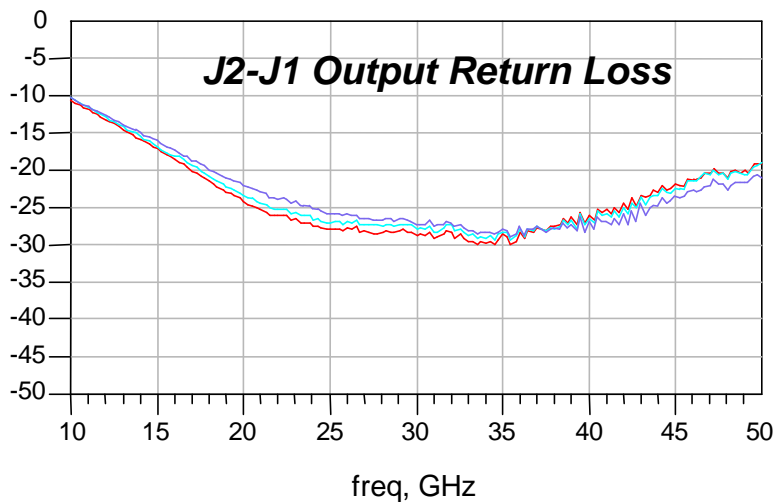

MA4BN1840-2 Outline

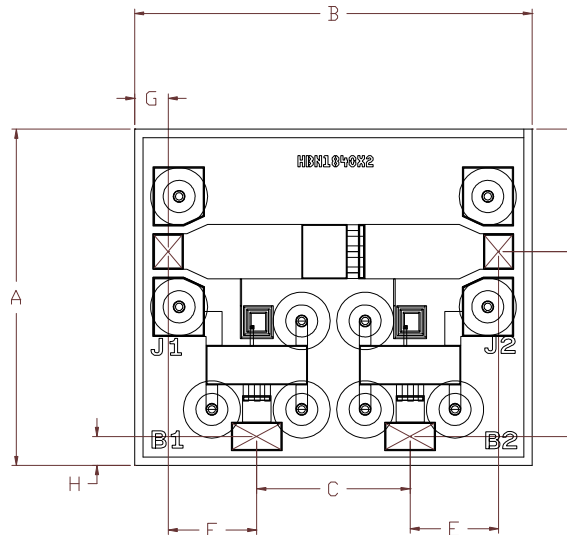

MA4BN1840-2 Outline Dimensions

Dim	mm		mils	
	Min.	Max.	Min.	Max.
A	57.7	58.9	1.47	1.78
B	68.7	69.9	1.75	1.08
C	26.3	27.5	0.67	0.70
D	31.4	32.6	0.80	0.83
E	14.8	19.0	0.38	0.41
F	20.6	21.8	0.52	0.55
G	5.3	6.4	0.13	0.16
H	4.4	5.6	0.11	0.14
RF Bond Pads	5.1 X 5.9 REF.		.130 X .150 REF.	
DC Bond Pads	8.7 X 4.7 REF.		.220 X .120 REF.	
Thickness	0.005 REF.		0.125 REF.	

Assembly Considerations

The following precautions should be observed to avoid damaging these chips.

Cleanliness

These chips should be handled in a clean environment. Do not attempt to clean die after installation.

Electro-Static Sensitivity

The MA4BN1840-2 Dual Bias Network is ESD, Class 1 sensitive. The proper ESD handling procedures should be used.

Wire Bonding

Thermosonic wedge wire bonding using 0.003" x 0.00025" ribbon or ball bonding with 0.001" diameter gold wire is recommended. A stage temperature of 150 °C and a force of 18 to 22 grams should be used. Ultrasonic energy should be adjusted to the minimum required. RF bonds should be as short as possible for best performance.

Mounting

These chips have Ti-Pt-Au topside and backside metal. They can be die mounted with a gold-tin or a lead-tin-silver eutectic solder preform or electrically conductive silver epoxy. Mounting surface must be clean of organic contaminants and flat for best adhesion results.

Eutectic Die Attachment

An 80/20 gold-tin eutectic solder preform is recommended with a work surface temperature of 255 °C and a tool tip temperature of 265 °C. When hot gas is applied, the tool tip temperature should be 290 °C. The chip should not be exposed to temperatures greater than 320 °C for more than 20 seconds. No more than three seconds should be required for attachment.

Electrically Conductive Epoxy Die Attachment

Assembly should be preheated to 125-150 °C. A minimum amount of epoxy should be used, approximately 1 to 2 mils thickness for best electrical and thermal conductivity. A thin epoxy fillet should be visible around the perimeter of the chip after placement. Cure epoxy per manufacturer's time-temperature schedule.

Operation of the MA4BN1840-2

Broadband operation of the MA4BN1840-2 Bias Network is accomplished by applying D.C. bias to the “ B1 “ and “ B2 “ D.C. bias ports on the die to the corresponding microwave device connected at the J1 and/or the J2 ports. The MA4BN1840-2 can be utilized to D.C. bias (2) devices simultaneously in conjunction with the MA4BN1840-1 that can be used as the D.C. Bias Return. The small D.C. resistance (< 1 Ω) of the D.C. Bias Port allows up to +/- 150 mA @ +/- 50 V to be delivered while still maintaining > 35 dB RF to D.C. isolation.

MA4BN1840-2 Schematic

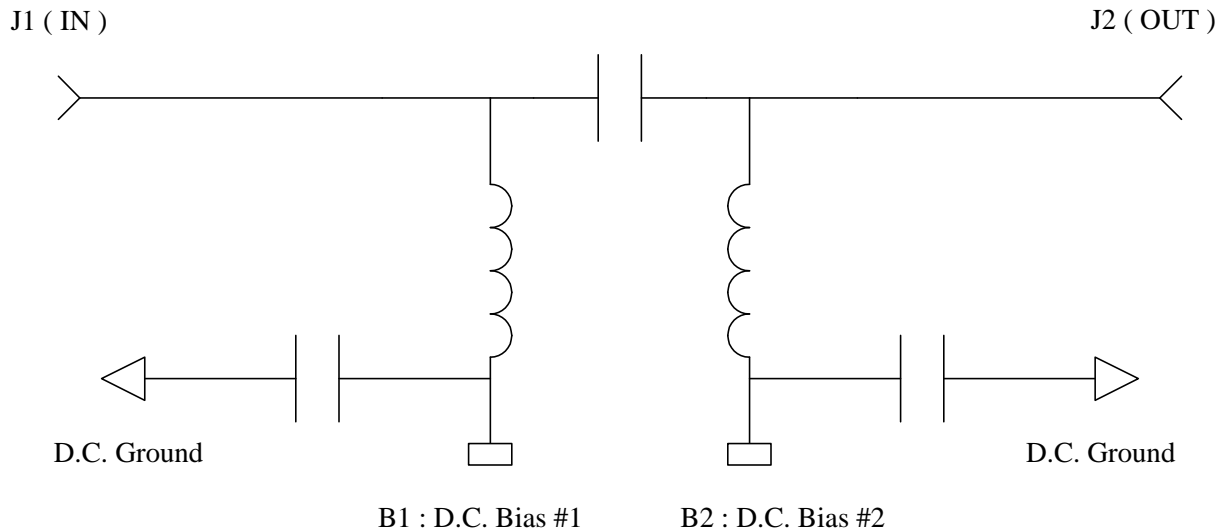

Biasing Applications Using the MA4BN1840-2 and the MA4BN1840-1

Series Diode Switch Biasing with D.C. Return

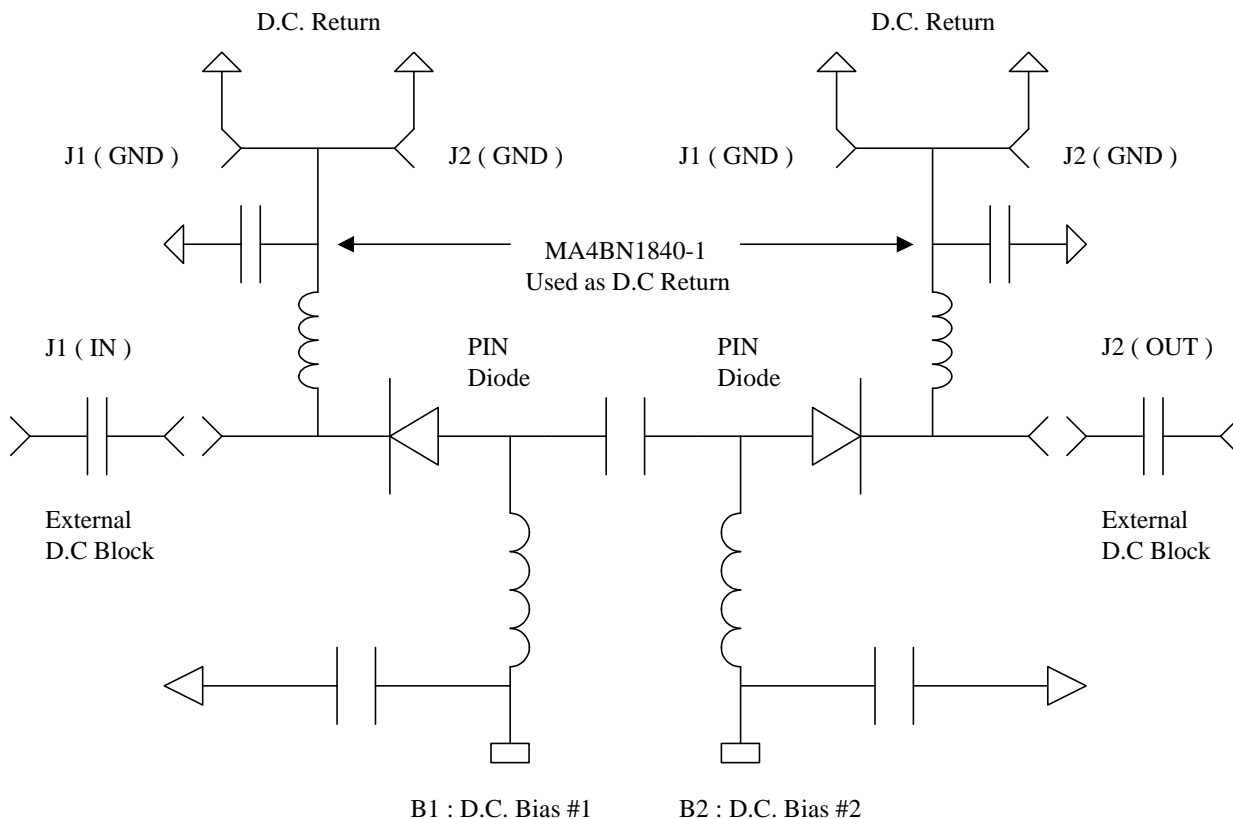

SP2T Shunt Diode Switch Biasing

