



# ESCC 4001/025 (e) Qualified High Precision Thin Film Chip Resistor Arrays



Vishay Sfernice Thin Film division holds ESCC QML qualification (ESCC technology flow qualification). PRA Hi-Rel arrays can be used in most applications requiring a matched pair (or set) of resistor elements. The networks provide 3 ppm/°C TCR tracking, a ratio tolerance as tight as 0.05 % and outstanding stability. They are available in 1 mm, 1.35, mm and 1.82 mm pitch.

## DIMENSIONS

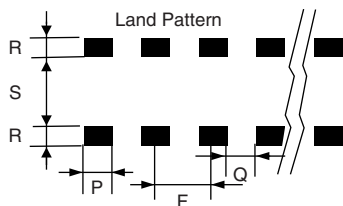

DIM.	PRA HR 100		PRA HR 135		PRA HR 182	
	mm	mil	mm	mil	mm	mil
A	1.6 <sup>+0.2</sup> / <sub>-0.1</sub>	63	1.85 <sup>+0.2</sup> / <sub>-0.1</sub>	72	3.0 <sup>+0.2</sup> / <sub>-0.1</sub>	118
B	0.34 ± 0.17	13	0.34 ± 0.17	13	0.34 ± 0.17	13
C	0.65 <sup>+0.15</sup> / <sub>-0.15</sub>	25.5	1.05 <sup>+0.15</sup> / <sub>-0.15</sub>	41	1.3 <sup>+0.35</sup> / <sub>-0.15</sub>	51
D	0.25	10	0.25	10	0.25	10
E <sup>(1)</sup>	E = (N x F) ± 0.2 mm		E = (N x F) ± 8 mil			
F	1	40	1.35	53.1	1.82	72
G	0.38 <sup>+0.2</sup> / <sub>-0</sub>	15	0.38 <sup>+0.2</sup> / <sub>-0</sub>	15	0.38 <sup>+0.2</sup> / <sub>-0</sub>	15
P	0.7	27.5	1.05	41.3	1.52	59.8
Q	0.3	12	0.3	12	0.3	12
R	1	40	1	40	1	40
S	0.6	23.5	0.8	31.5	1.8	70.8

**Note**

<sup>(1)</sup> E depends on number of resistors

## FEATURES

HALOGEN  
**FREE**

- Thin film technology
- High stability passivated nichrome resistive layer 0.02 % on ratio, 1000 h at Pn at +70 °C
- Tight TCR (10 ppm/°C) and TCR tracking (3 ppm/°C)
- Very low noise < -35 dB and voltage coefficient < 0.01 ppm/V
- Ratio tolerance to 0.01 % (R ≥ 200R)
- Pre-tinned terminations over nickel barrier
- ESA/ESCC qualified
- ESCC 4001 (generic specification)
- ESCC 4001/025 (detailed specification)
- SMD wraparound chip resistor array
- Up to eight different ohmic values (CNW HR)
- Suitable for military use
- Material categorization: for definitions of compliance please see [www.vishay.com/doc?99912](http://www.vishay.com/doc?99912)

## TYPICAL PERFORMANCE

	ABSOLUTE	TRACKING
TCR	10 ppm/°C	3 ppm/°C
	ABSOLUTE	RATIO
TOL.	0.1 %	0.05 %

TC tracking: 3 ppm/°C if all resistors of the array are: Rn > 250 Ω

TC tracking: 5 ppm/°C if one or more resistors of the array is in the range: 100 Ω to 250 Ω included

### I: Independent resistors

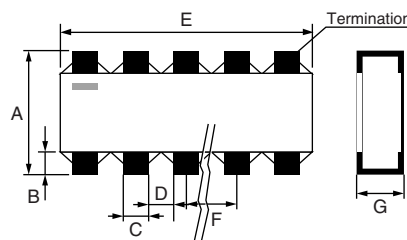

### Electrical diagram

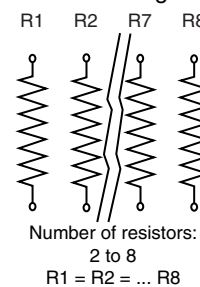

### C: One common point N resistors

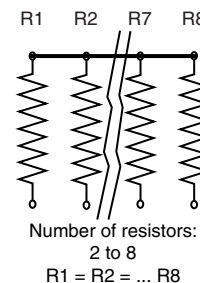
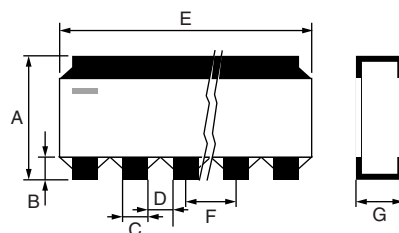

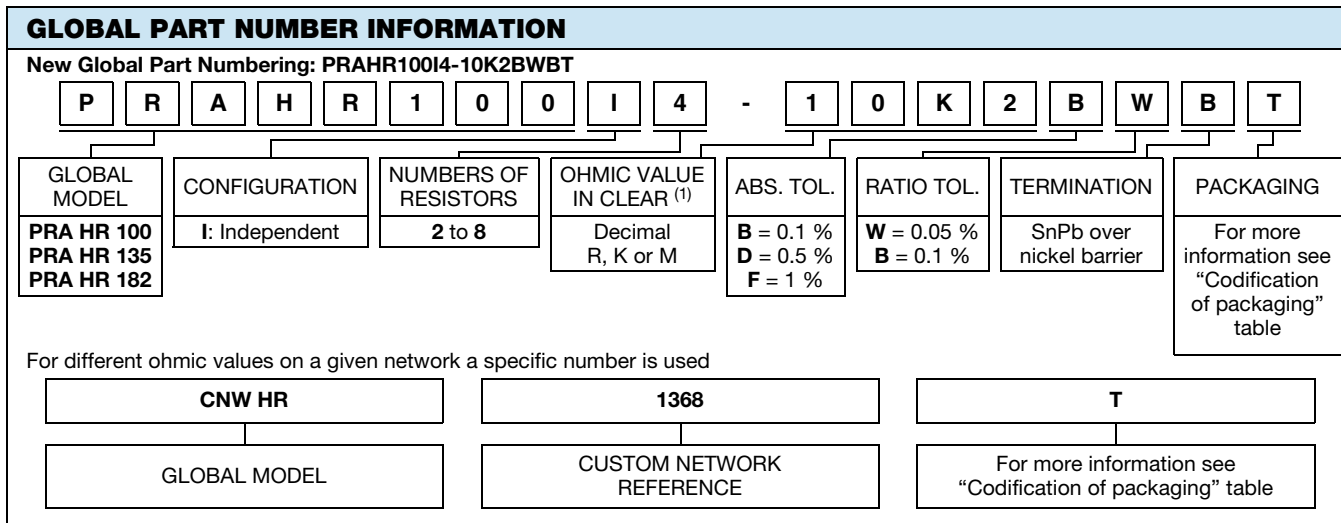

**Notes**

- Part number is limited to 18 digits, so packing might be omitted and mentioned in comment on order
- <sup>(1)</sup> When the last digit(s) of the ohmic value is (are) 0, it (they) can be omitted.  
E.g.:PRAHR100I4-2K20BWN → can be ordered under PRAHR100I4-2K2BWN  
PRAHR100I4-2K00BWN → can be ordered under PRAHR100I4-2KBWN

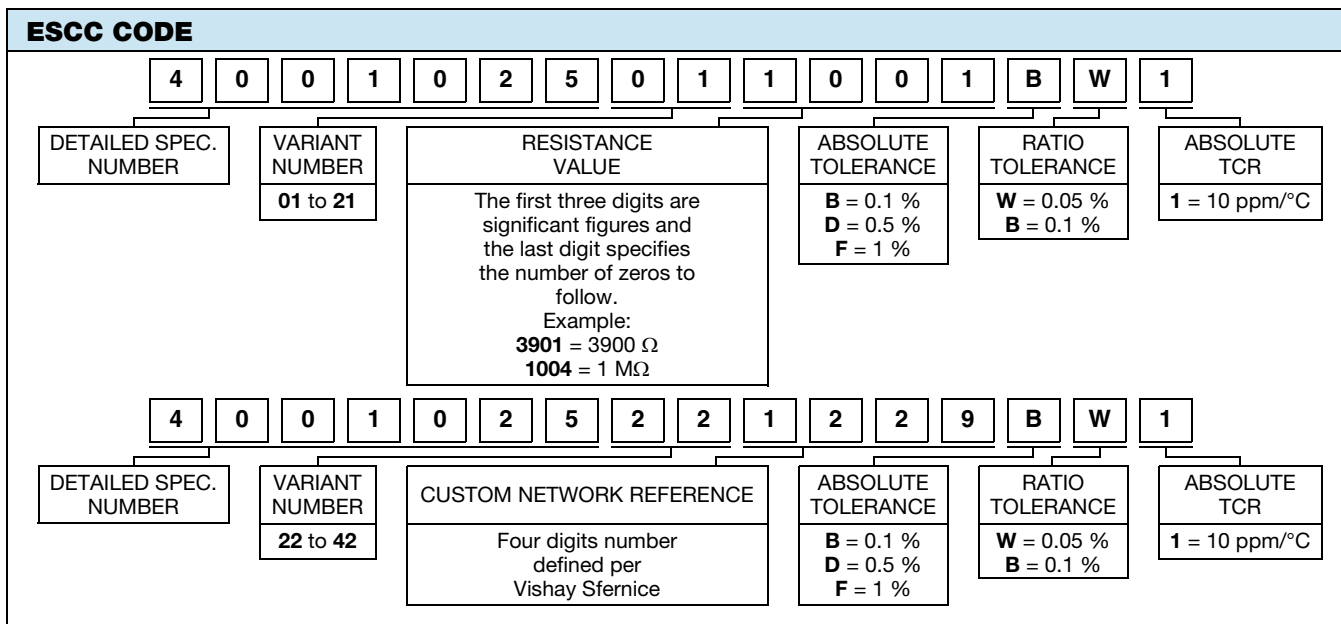

### CODIFICATION OF PACKAGING

CODE 18	PACKAGING
<b>WAFFLE PACK</b>	
W	25 min., 1 mult
<b>PLASTIC TAPE (Standard for all sizes.)</b>	
T	50 min., 1 mult
TA	100 min., 100 mult
TB	250 min., 250 mult
TC	500 min., 500 mult
TD	1000 min., 1000 mult
TE	2500min., 2500 mult
TF	Full tape (quantity depending on size of chips)



EXAMPLES OF CROSS REFERENCE BETWEEN ESA PART NUMBER AND VISHAY PART NUMBER						
ESA PART NUMBER	VISHAY PART NUMBER	EXPLANATIONS				
4001025011001BW1	PRAHR100I2-1K00BWB	4001025 = PRAHR or CNWHR	01 = 100I2 with 2 identical values and B termination	1001 = 1K00	BW = BW	1 = TCR 10 ppm abs: not mentioned in Vishay P/N
4001025221229BW1	CNWHR1229	4001025 = PRAHR or CNWHR	22 = 100I2 with 2 different values, B terminations	1229 = Vishay custom reference number	BW = Tolerances mentioned in custom file	1 = TCR 10 ppm abs: not mentioned in Vishay P/N

CROSS REFERENCE ESA PART NUMBER AND PRAHR PART NUMBER							
VARIANT ESA	VISHAY MODELS	VARIANT ESA	VISHAY MODELS	VARIANT ESA	VISHAY MODELS	VARIANT ESA	VISHAY MODELS
01	PRAHR100I2 same value	15	PRAHR182I2 same value	29	PRAHR135I2 different value		
02	PRAHR100I3 same value	16	PRAHR182I3 same value	30	PRAHR135I3 different value		
03	PRAHR100I4 same value	17	PRAHR182I4 same value	31	PRAHR135I4 different value		
04	PRAHR100I5 same value	18	PRAHR182I5 same value	32	PRAHR135I5 different value		
05	PRAHR100I6 same value	19	PRAHR182I6 same value	33	PRAHR135I6 different value		
06	PRAHR100I7 same value	20	PRAHR182I7 same value	34	PRAHR135I7 different value		
07	PRAHR100I8 same value	21	PRAHR182I8 same value	35	PRAHR135I8 different value		
08	PRAHR135I2 same value	22	PRAHR100I2 different value	36	PRAHR182I2 different value		
09	PRAHR135I3 same value	23	PRAHR100I3 different value	37	PRAHR182I3 different value		
10	PRAHR135I4 same value	24	PRAHR100I4 different value	38	PRAHR182I4 different value		
11	PRAHR135I5 same value	25	PRAHR100I5 different value	39	PRAHR182I5 different value		
12	PRAHR135I6 same value	26	PRAHR100I6 different value	40	PRAHR182I6 different value		
13	PRAHR135I7 same value	27	PRAHR100I7 different value	41	PRAHR182I7 different value		
14	PRAHR135I8 same value	28	PRAHR100I8 different value	42	PRAHR182I8 different value		

### TRACEABILITY DEFINITIONS

The two major traceability elements are defined as:

- The primary process lot number named Front End lot (FE lot). One "FE lot" is composed of several wafers issued from the same thin film deposition sequence.
- The date code named Batch Number (BN). The "BN" is defined after completion of the end of production testing sequence. The lot homogeneity is given by the "FE lot" and not by the "BN".

According to the applied rules validated by the ESCC through the product qualification, the following situations are agreed:

- Parts coming from different "FE lot" might have the same "BN".
- A maximum of two different "BN" might be applied to the same "FE lot" to enable the use of overruns from a previous PO.
- Unless requested / approved by the customer the "BN" will be 2 years old maximum.

### SPECIFIC TRACEABILITY REQUIREMENTS

The following specific requirements have to be treated as:

- A customer who requires "Lot Homogeneity" has to mention it on the PO as "SINGLE PRODUCTION LOT".
- A customer who requires "Lot Homogeneity" in addition to a "Single Batch Number" has to mention it on the PO as "SINGLE PRODUCTION LOT AND OPTION R0101".

### END OF PRODUCTION TESTING

Mandatory testing performed at the end of the production process:

- 100 % overload: Voltage  $\sqrt{(6.25 P_n \times R_n)}$  or 2 UL whichever is less - duration 2 s
- 100 % burn in: 168 h at  $P_n$  at 70 °C



## OPTIONS

### LOT VALIDATION TESTING

For procurement of qualified components, lot validation testing is not required and shall only be performed if specifically stipulated in the purchase order.

For procurement of unqualified components, lot validation testing shall be performed as stipulated in the purchase order. The need for lot validation testing shall be determined by the orderer.

When lot validation testing is required, it shall consist of the performance of one or more of the tests or subgroup test sequences of chart F4 indicated in the ESA Generic Specification ESCC 4001. The testing to be performed and the sample size shall be as stipulated in the purchase order. When procurement of more than one component type is involved from a family, range or series, the selection of representative samples shall also be stipulated in the purchase order.

Lot validation testing will be composed of one LVT charges and LVT samples:

Lot validation test charges has to be ordered separately on purchase order.

Lot validation samples have to be ordered separately on purchase order.

### FINAL INSPECTION

If requested by the orderer a final inspection can be performed on site.

Final inspection has to be stipulated separately on purchase order.

STANDARD ELECTRICAL SPECIFICATIONS							
MODEL	SIZE	RESISTANCE RANGE $\Omega$	POWER RATING <sup>(1)</sup> W	ABSOLUTE TOLERANCE $\pm$ %	RATIO TOLERANCE %	ABSOLUTE TCR <sup>(2)</sup> $\pm$ ppm/ $^{\circ}$ C	RATIO TCR <sup>(3)</sup> $\pm$ ppm/ $^{\circ}$ C
PRA HR 100	100	100 to 200K	0.100	0.1, 0.5, 1	0.05, 0.1	10	3
PRA HR 135	135	100 to 250K	0.100	0.1, 0.5, 1	0.05, 0.1	10	3
PRA HR 182	182	100 to 1M	0.100	0.1, 0.5, 1	0.05, 0.1	10	3

#### Notes

(1) Per resistor at +70  $^{\circ}$ C

(2) At -40  $^{\circ}$ C +155  $^{\circ}$ C

(3) If all resistors of the array are:  $R_n > 250 \Omega$  at -40  $^{\circ}$ C to +155  $^{\circ}$ C

PERFORMANCES			
TEST		SPECIFICATIONS	CONDITION
Soldering temperature		260 $^{\circ}$ C	Max.
Limiting voltage	PRA HR 100	35 V	
	PRA HR 135	75 V	
	PRA HR 182	100 V	
Insulation voltage	PRA HR 100	70 V <sub>RMS</sub>	
	PRA HR 135	150 V <sub>RMS</sub>	
	PRA HR 182	200 V <sub>RMS</sub>	

CLIMATIC SPECIFICATIONS	
Operating temperature range	-65 $^{\circ}$ C to +155 $^{\circ}$ C
Storage temperature range	-65 $^{\circ}$ C to +155 $^{\circ}$ C

MECHANICAL SPECIFICATIONS	
Substrate	Alumina
Technology	Thin Film
Film	Nickel chromium with mineral passivation
Terminations	<b>B type:</b> SnPb over nickel barrier

### SPECIAL FEATURES

Resistance values can be different on a given network ( $R_{max}/R_{min}$  as high as 300). Tooling charges might be required depending on the ohmic values in the same network. Please, consult Vishay Sfernice for ohmic values, tolerances and also temperature coefficient outside the standard range.

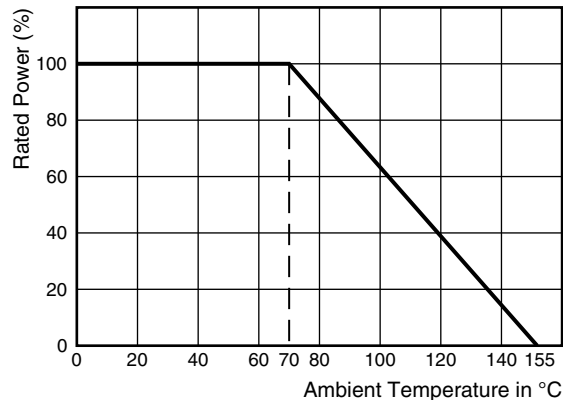
**POWER RATING****PACKAGING**

Several types of packaging are available: Waffle-pack and tape and reel.

SIZE	MOQ	NUMBER OF PIECES PER PACKAGE			
		WAFFLE PACK MAX. QUANTITY PER BOX	TAPE AND REEL <sup>(1)</sup>		
			MIN.	MAX.	
PRA100 x 2	25 in waffle pack	100	50	4000	
PRA100 x 3		140	50	4000	
PRA100 x 4		60	50	4000	
PRA100 x 5		50			
PRA100 x 6		50 in tape and reel	50	50	3000
PRA100 x 7			50		
PRA100 x 8			28	50	4000
PRA135 x 2			25 in waffle pack	140	50
PRA135 x 3	60				
PRA135 x 4	60	50		2500	
PRA135 x 5	50				
PRA135 x 6	50 in tape and reel	28		50	4000
PRA135 x 7		24			
PRA135 x 8		24			
PRA182 x 2		25 in waffle pack		60	50
PRA182 x 3	60		50	4000	
PRA182 x 4	50		50	2000	
PRA182 x 5	21		50	4000	
PRA182 x 6	50 in tape and reel		24		
PRA182 x 7			24		
PRA182 x 8			20		

**Note**

<sup>(1)</sup> Other sizes upon request



## MARKING

The marking of all components delivered to this specification shall be in accordance with the requirements of ESCC Basic Specifications No. 21700. When the component is too small to accommodate all of the marking specified, as much as space permits shall be marked and the marking information, in full, shall accompany each component in its primary package.

The information to be marked and the order of precedence, shall be as follows:

- Rated Resistance (for variants 01 to 21); Terminal identification and array reference code (for variants 22 to 42) (see Physical Dimensions and Terminal Identification)
- The ESCC qualified components symbol (for ESCC qualified components only)
- The ESCC component number
- Traceability information

Terminal identification shall be by means of the location of the marking. Due to the size of the component only the 4 digit resistance value code or array reference code, as applicable (see the ESCC component number), shall be marked on the component.

For symmetrical marking using reversible figures such as 0, 6 or 9, the first resistor of the array, R1, shall be identified by a dot. For arrays with 2 or 3 resistors, the marking shall be located adjacent to the first 2 resistors of the array. The first resistor, R1, of the array is the upper resistor whilst reading the marking, as follows:

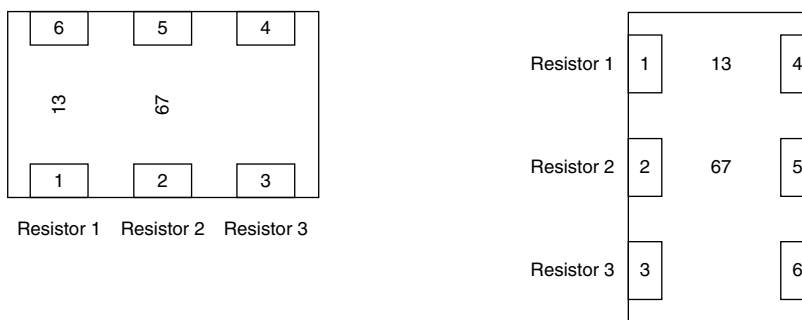

For arrays with 4 to 8 resistors, the marking shall be located adjacent to the first 4 resistors of the array. The first resistor, R1, of the array is on the left hand end of the array whilst reading the marking, as follows:

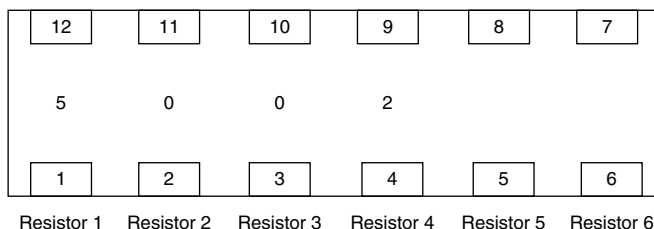

PERFORMANCE			
TESTS	CONDITIONS CECC REQUIREMENTS	DRIFTS	
		ABSOLUTE PER (TYPICAL VALUES)	RATIO
Overload	2.5 Un/2 s	0.05 % Rn + 0.05 Ω	0.01 % Rn
Climatic sequences	-55 °C to +155 °C/5 moisture cycles	0.1 % Rn + 0.05 Ω	0.01 % Rn
Thermal shock	-55 °C to +155 °C/5 cycles 30'	0.05 % Rn + 0.05 Ω	0.01 % Rn
Load life	1000 h/Pn at +70 °C	0.1 % Rn + 0.05 Ω	0.02 % Rn
	2000 h	0.15 % Rn + 0.05 Ω	
Resistance to solder heat	260 °C/10 s	0.05 % Rn + 0.05 Ω	0.01 % Rn
Moisture resistance	0.01 Pn at 40 °C 93 % RH	0.1 % Rn + 0.05 Ω	0.01 % Rn
High temperature storage	1000 h/no load at +155 °C	0.1 % Rn + 0.05 Ω	0.02 % Rn

### Note

- Rn: Nominal resistance



## **Disclaimer**

ALL PRODUCT, PRODUCT SPECIFICATIONS AND DATA ARE SUBJECT TO CHANGE WITHOUT NOTICE TO IMPROVE RELIABILITY, FUNCTION OR DESIGN OR OTHERWISE.

Vishay Intertechnology, Inc., its affiliates, agents, and employees, and all persons acting on its or their behalf (collectively, "Vishay"), disclaim any and all liability for any errors, inaccuracies or incompleteness contained in any datasheet or in any other disclosure relating to any product.

Vishay makes no warranty, representation or guarantee regarding the suitability of the products for any particular purpose or the continuing production of any product. To the maximum extent permitted by applicable law, Vishay disclaims (i) any and all liability arising out of the application or use of any product, (ii) any and all liability, including without limitation special, consequential or incidental damages, and (iii) any and all implied warranties, including warranties of fitness for particular purpose, non-infringement and merchantability.

Statements regarding the suitability of products for certain types of applications are based on Vishay's knowledge of typical requirements that are often placed on Vishay products in generic applications. Such statements are not binding statements about the suitability of products for a particular application. It is the customer's responsibility to validate that a particular product with the properties described in the product specification is suitable for use in a particular application. Parameters provided in datasheets and / or specifications may vary in different applications and performance may vary over time. All operating parameters, including typical parameters, must be validated for each customer application by the customer's technical experts. Product specifications do not expand or otherwise modify Vishay's terms and conditions of purchase, including but not limited to the warranty expressed therein.

Except as expressly indicated in writing, Vishay products are not designed for use in medical, life-saving, or life-sustaining applications or for any other application in which the failure of the Vishay product could result in personal injury or death. Customers using or selling Vishay products not expressly indicated for use in such applications do so at their own risk. Please contact authorized Vishay personnel to obtain written terms and conditions regarding products designed for such applications.

No license, express or implied, by estoppel or otherwise, to any intellectual property rights is granted by this document or by any conduct of Vishay. Product names and markings noted herein may be trademarks of their respective owners.