

FERROXCUBE

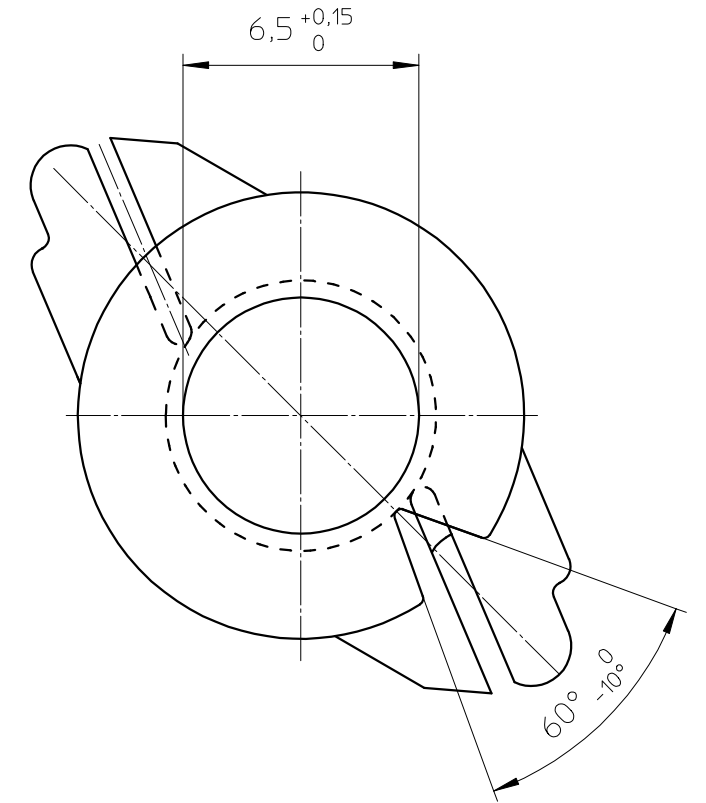

HOLE PATTERN:

Space requirement 6x6 pitch.

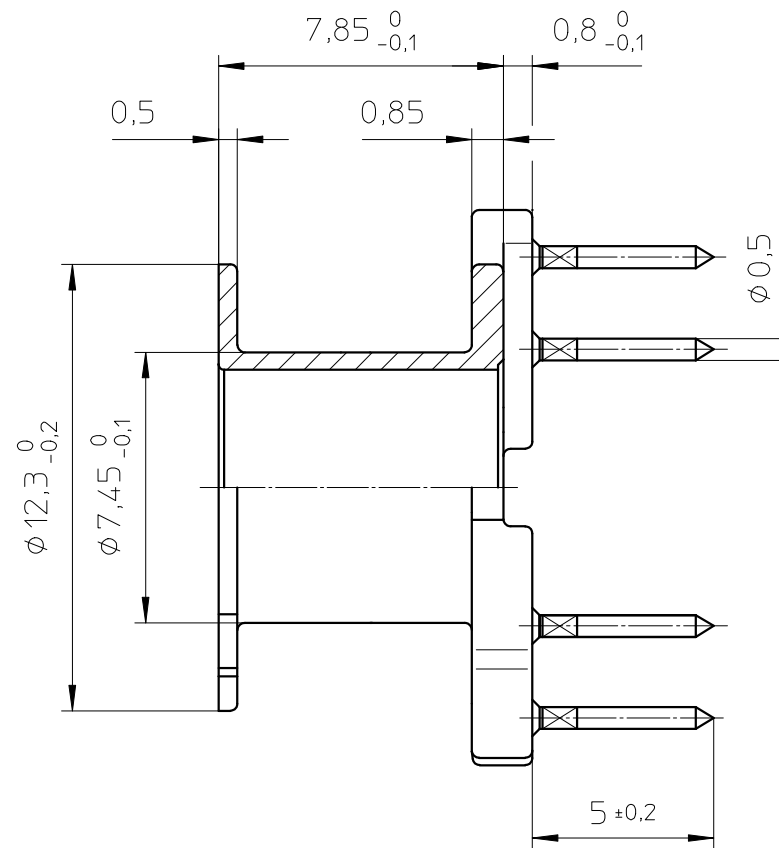
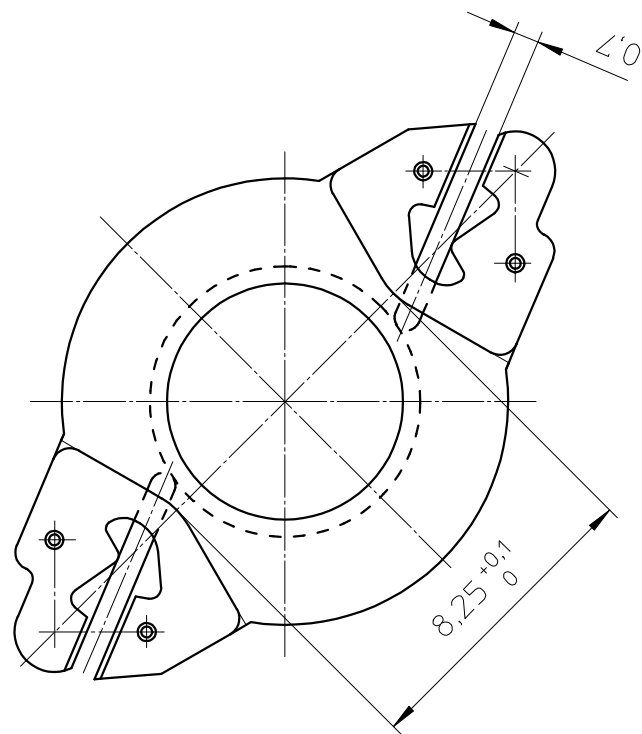
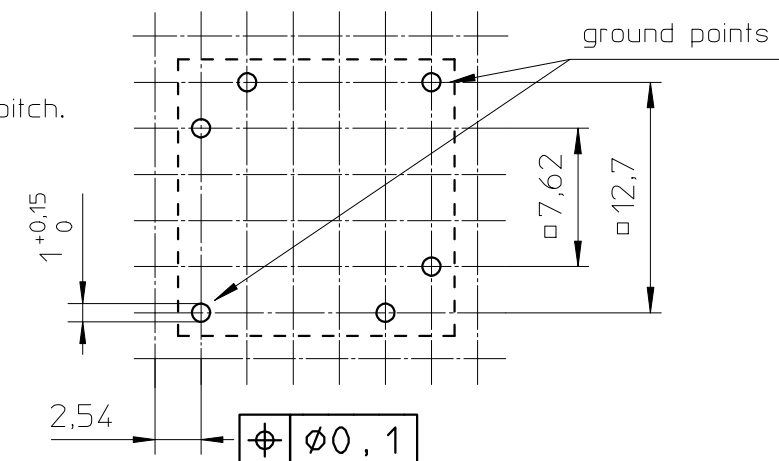

Coil former material: Bakelite UP 3420 (UP), glass-reinforced.
 UL file number: E61040 - UL94V-0.
 Pin material: CuSn - Ni flash, Sn plated.
 Max. operating temp.: acc. to IEC 60 085 class H, 180°C.
 Resistance to soldering heat: acc. to IEC 60 068-2-20 Part 2, Test Tb, method 1B, 350°C-3.5s.
 Solderability: acc. to IEC 60 068-2-20 Part 2, Test Ta, method 1, 235°C-2s.
 Min. winding area: 15 mm.²
 Mean length of turn: 30 mm.

CLASS.NO.	00-05-04		NAME NAAM M.Veekens		SUPERS. VERV.	1	SH BL.	SH BL.	112	-	001	010	94-06-17
CSV-RM6S-1S-4P			4322 021 00981									99-10-06	
												00-05-04	
												03-06-30	
												05-09-01	
MPA	CHECK CONTR.	DAT.	03-04-01	Property of Eigendom van	© FERROXCUBE 2000								A3