

NOTES:

1. CONNECTOR MATERIAL:  
HOUSING:THERMOPLASTIC UL94 V-0  
SHIELD:Brass  
SHIELD PLATING:NICKEL  
CONTACT:COOPER ALLOY  
CONTACT PLATING: SELECTIVE GOLD, 6 MICRO-INCHS MIN  
IN CONTACT AREA
2. PIN NOT ELECTRICALLY CONNECTED MAYBE OMITTED SEE  
ELECTRICAL DRAWING FOR OMITTED PINS
3. RJ45 CAVITIES CONFORM TO FCC RULES AND REGULATION  
PART 68.
4. THE PART IS RECOMMENDED FOR WAVE SOLDERING  
PROCESS PEAK SOLDERING TEMPERATURE IS  
260°C MAX, 10 SECS MAX
5. OPERATING TEMPERATURE T=0°C TO +70°C.
6. STORAGE TEMPERATURE T=-40°C TO +85°C.
7. All CRITICAL DIMENSIONS WITH "\*"
8. PACKAGING INFORMATION: 50 PCS/TRAY, 1200 PCS/BOX.

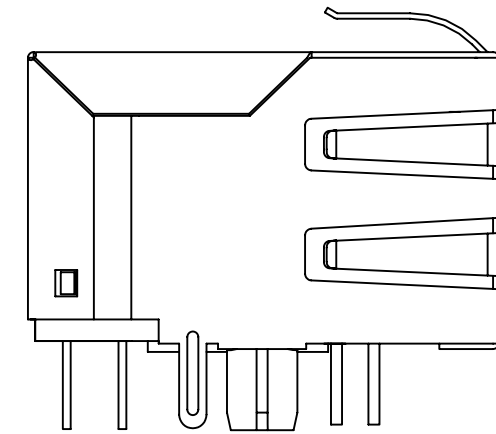
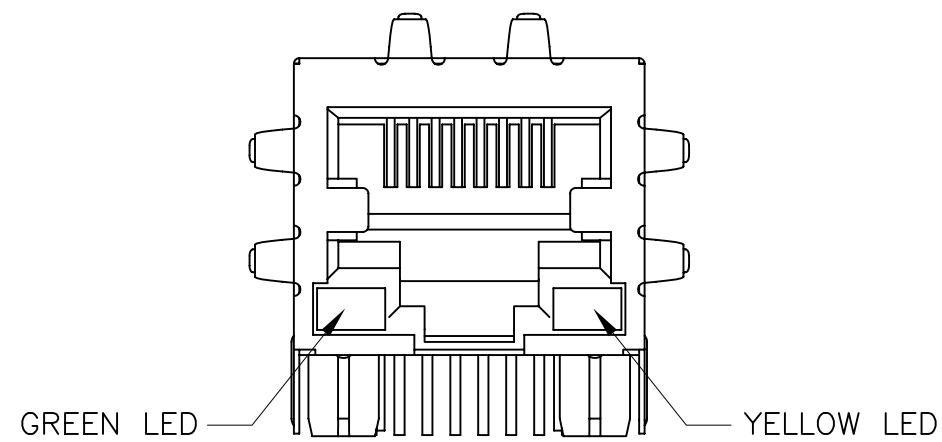
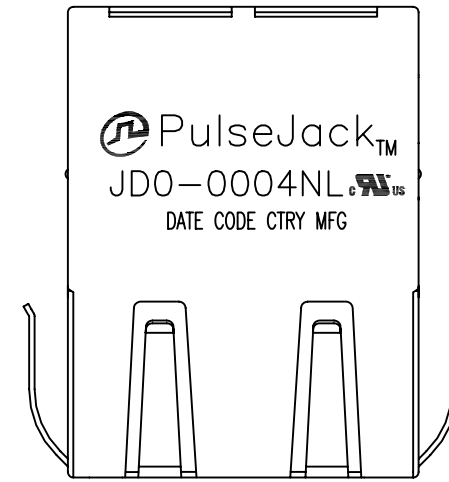

FINAL OUTLINE

© Copyright, 2015. Pulse Electronics Corp. All rights reserved. Pulse confidential & proprietary. (01/26/15)

PRODUCT DESCRIPTION	TLA DRAWING	PS DRAWING	SHEET	PART NO.	DATASHEET REV.
CONN,RJ45,1X1,100D,1:1,TU	JDO-0004NL-X1	-	1 OF 5	JDO-0004NL	A

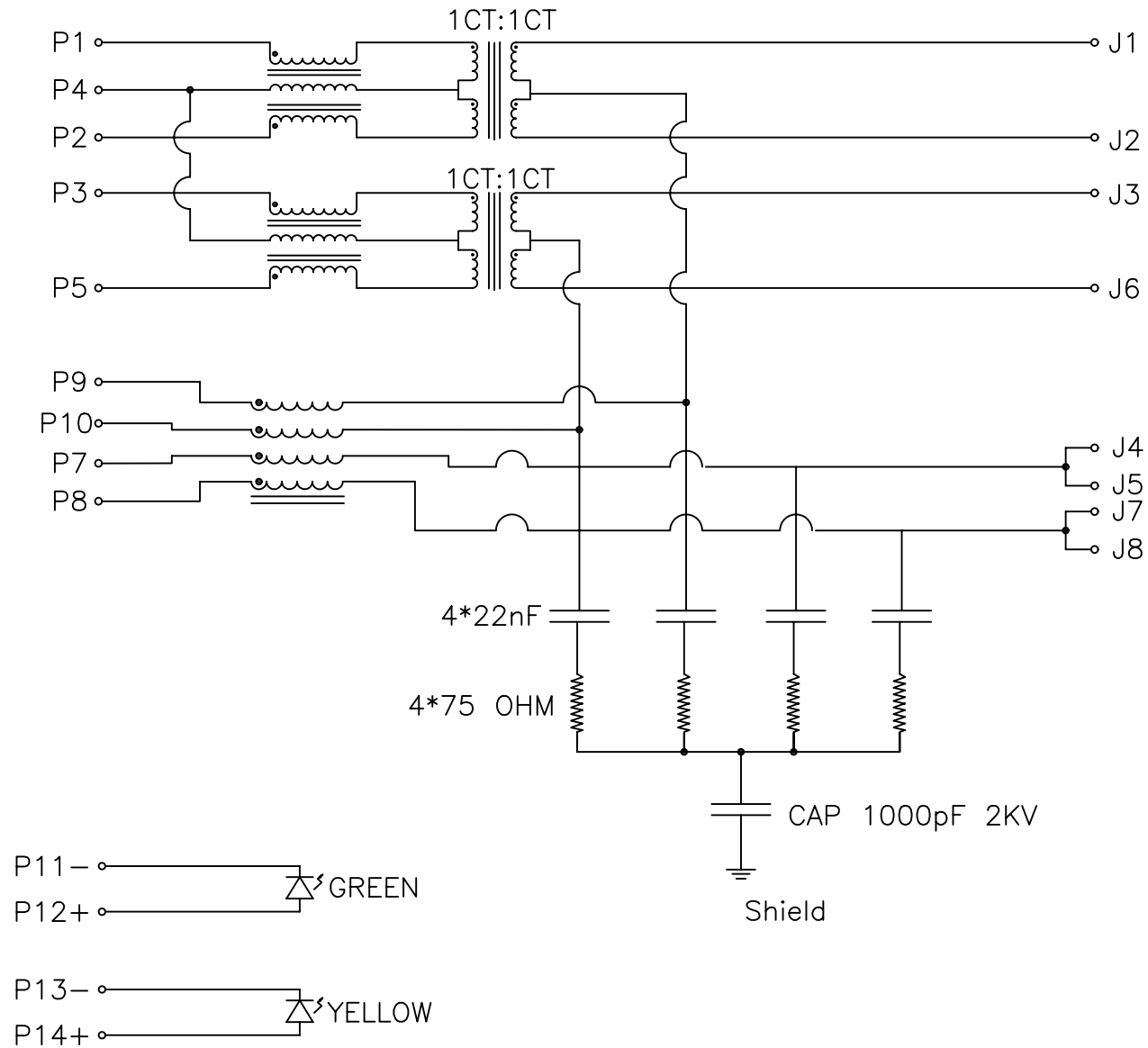

SCHEMATIC

Electronical Specifications:

- 1.0 Turn Ratio @100KHz: (P1~P2):(J1~J2) = 1:1±5%  
(P3~P5):(J3~J6) = 1:1±5%
- 2.0 Primary Inductance: 350uH MIN @100KHZ,0.1V 8mA DC BIAS
- 3.0 DC Resistance:(J1~J2):(J3~J6) 1.2 OHMS MAX
- 4.0 Insertion Loss: 1-100MHz -1.2dB MAX
- 5.0 Return Loss: 1-30MHz -16dB MIN  
30-60MHz -12dB MIN  
60-80MHz -10dB MIN
- 6.0 CROSS TALK: 1-100MHz -30dB MIN
- 7.0 COMMON TO COMMON MODE ATTENUATION: 1-100MHz -30dB MIN
- 8.0 Isolation: PHY Side to Line Side: 1500VAC or 2250VDC
- 9.0 DC CURRENT/VOLTAGE RATING-PSE PINS: 350mA @57V(CONTINUOUS)

LED SPECIFICATION:

STANDARD LED	WAVELENGTH	Forward V(max)	TYP
GREEN	565nm	2.4V	2.2V
YELLOW	590nm	2.5V	2.1V

\*WITH A FORWARD CURRENT OF 20mA

© Copyright, 2015. Pulse Electronics Corp. All rights reserved. Pulse confidential & proprietary. (01/26/15)

PRODUCT DESCRIPTION	TLA DRAWING	PS DRAWING	SHEET	PART NO.	DATASHEET REV.
CONN,RJ45,1X1,100D,1:1,TU	JDO-0004NL-X1	-	2 OF 5	JDO-0004NL	A

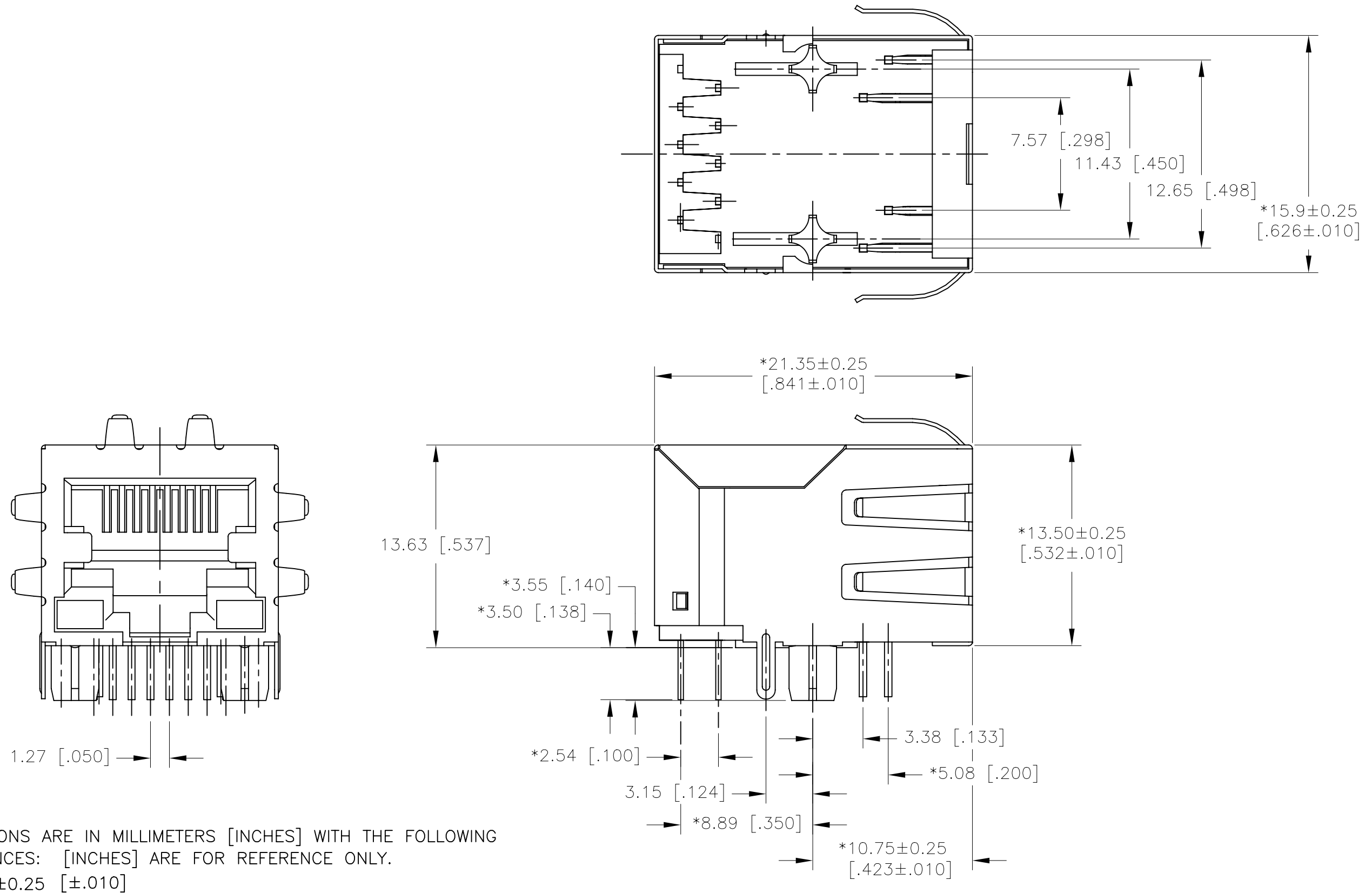

© Copyright, 2015. Pulse Electronics Corp. All rights reserved. Pulse confidential & proprietary. (01/26/15)

PRODUCT DESCRIPTION	TLA DRAWING	PS DRAWING	SHEET	PART NO.	DATASHEET REV.
CONN,RJ45,1X1,100D,1:1,TU	JDO-0004NL-X1	-	3 OF 5	JDO-0004NL	A

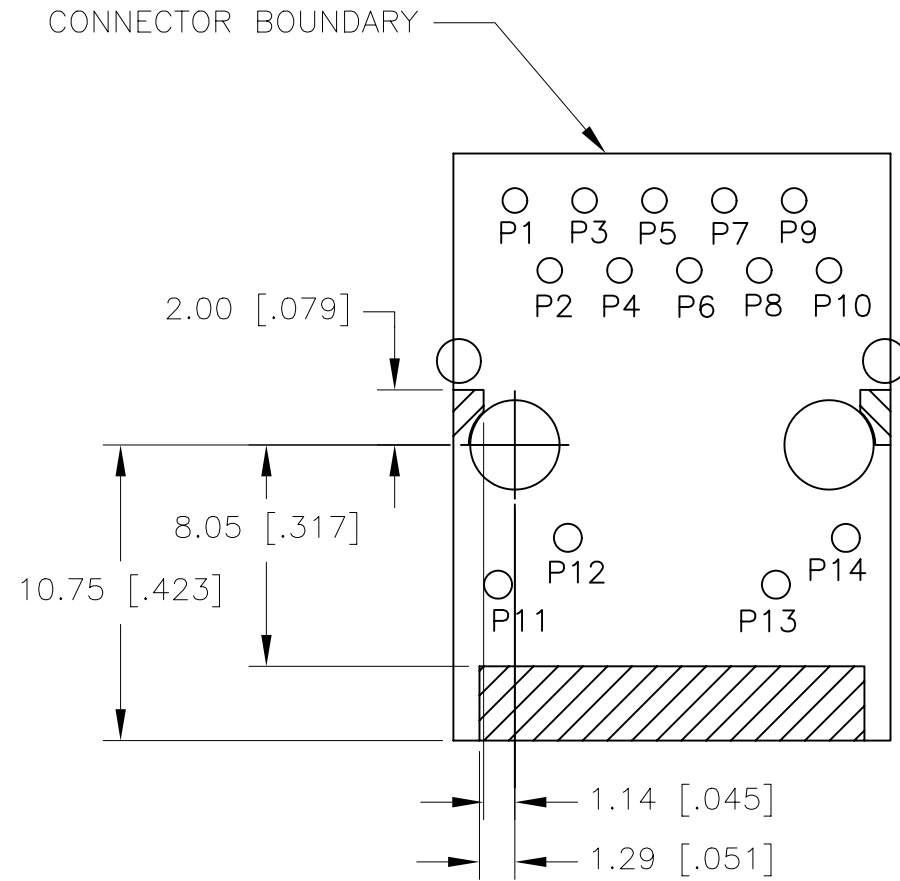

KEEP-OUT AREA (COMPONENT SIDE SHOWN)

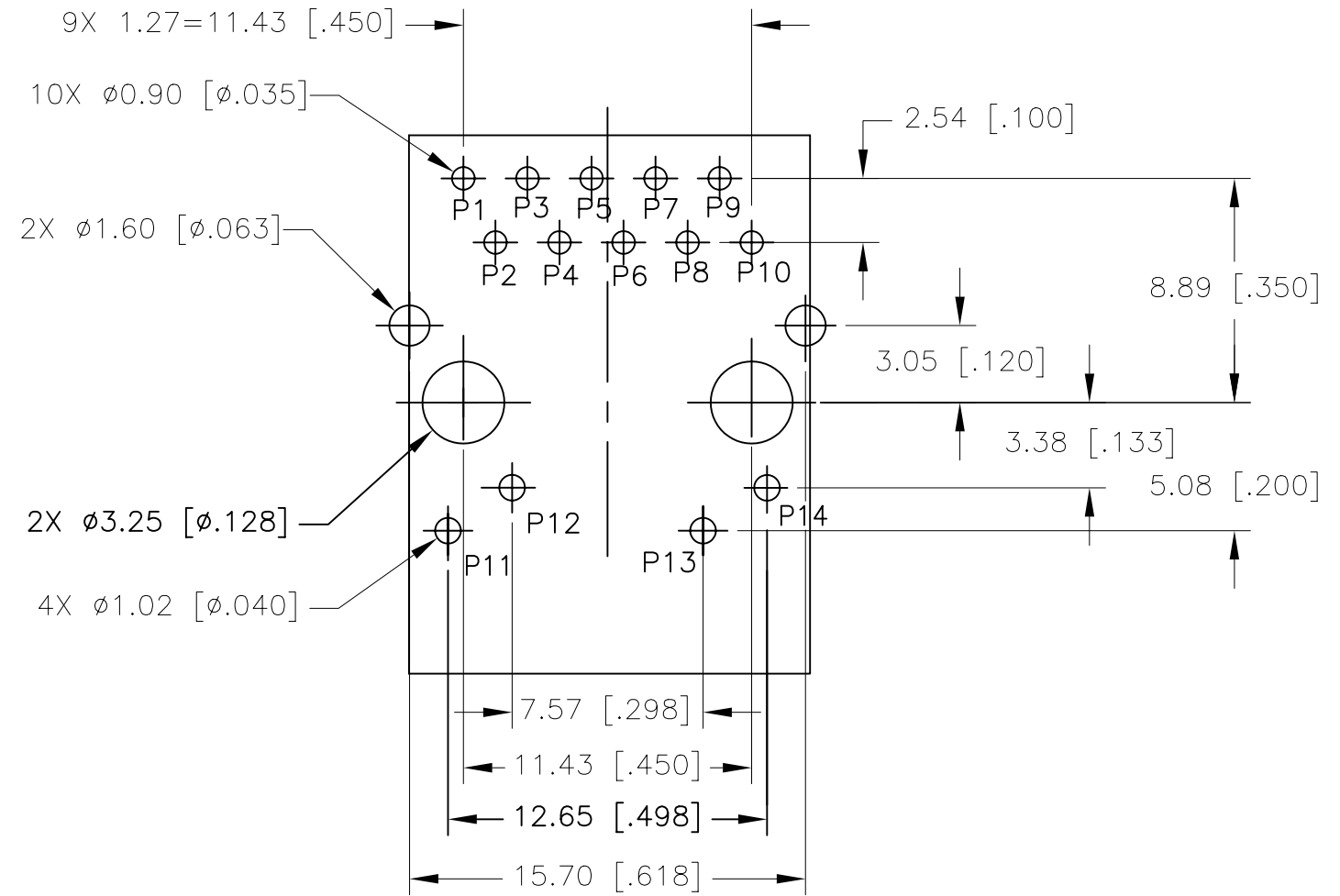

RECOMMENDED PWB LAYOUT  
(COMPONENT SIDE SHOWN)

DIMENSIONS ARE IN MILLIMETERS [INCHES] WITH THE FOLLOWING TOLERANCES: [INCHES] ARE FOR REFERENCE ONLY.  
X.XX= ±0.10 [±.004]

© Copyright, 2015. Pulse Electronics Corp. All rights reserved. Pulse confidential & proprietary. (01/26/15)

PRODUCT DESCRIPTION	TLA DRAWING	PS DRAWING	SHEET	PART NO.	DATASHEET REV.
CONN,RJ45,1X1,100D,1:1,TU	JDO-0004NL-X1	-	4 OF 5	JDO-0004NL	A

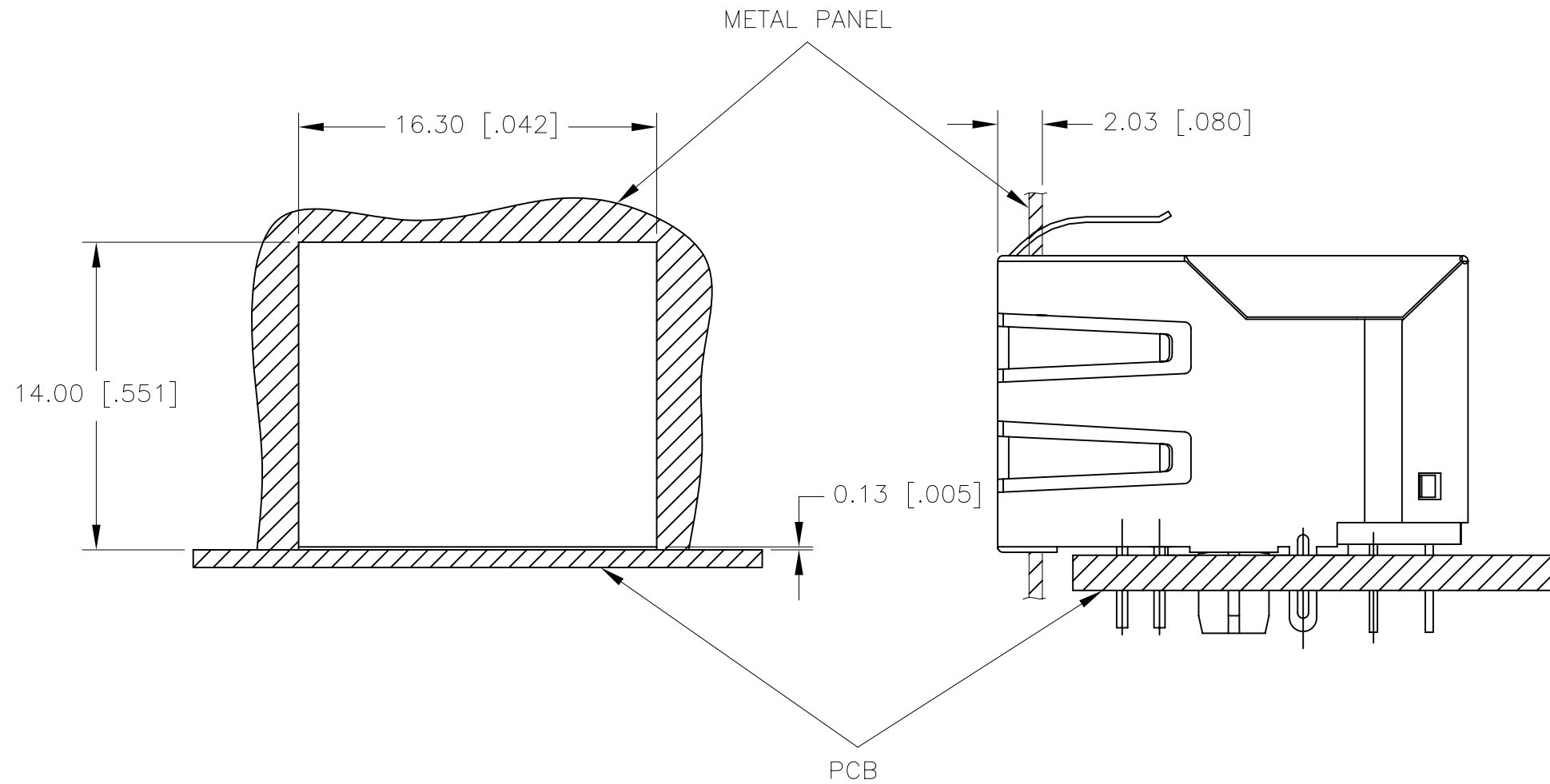

SUGGESTED PANEL CUTOUT

DIMENSIONS ARE IN MILLIMETERS [INCHES] WITH THE FOLLOWING  
TOLERANCES: [INCHES] ARE FOR REFERENCE ONLY.  
X.XX=  $\pm 0.10$  [ $\pm 0.004$ ]

© Copyright, 2015. Pulse Electronics Corp. All rights reserved. Pulse confidential & proprietary. (01/26/15)

PRODUCT DESCRIPTION	TLA DRAWING	PS DRAWING	SHEET	PART NO.	DATASHEET REV.
CONN,RJ45,1X1,100D,1:1,TU	JDO-0004NL-X1	-	5 OF 5	JDO-0004NL	A