



# Linear Integrated Circuit

**KA3842A**  
**KA3842AM**

## CURRENT-MODE PWM CONTROLLER

The KA3842A, KA3842AM are fixed frequency current-mode PWM controller. They are specially designed for OFF-Line and DC-to-DC converter applications with minimal external components. These integrated circuits feature a trimmed oscillator for precise duty cycle control, a temperature compensated reference, high gain error amplifier, current sensing comparator, and a high current totempole output ideally suited for driving a power MOSFET.

Protection circuitry includes built under-voltage lockout and current limiting.

The KA3842A, KA3842AM have UVLO thresholds of 16 V(on) and 10 V (off).

The KA3842A, KA3842AM operate within 100% duty cycle. The KA3842A has been proven in applications using the same external components as Motorola's parts, among others. The KA3842AM

has been optimized for compatibility with Samsung's parts. Many applications can use either KA3842A or KA3842AM. The KA3842A, KA3842AM have Start-Up Current 0.45 mA.

## PIN CONNECTION

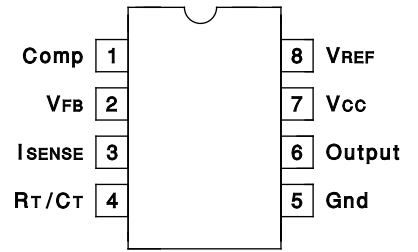

SO-8

DIP-8

## FEATURES

- Low Start-Up Current
- Maximum Duty Cycle
- U/V Lockout With Hysteresis
- Operating Frequency Up To 500kHz

## ordering information

Device	Package	Operating temperature
KA3842AM	SO-8	0 to +70°C
KA3842AMM	SO-8	"
KA3842AN	DIP-8	"
KA3842AMN	DIP-8	"

## BLOCK DIAGRAM

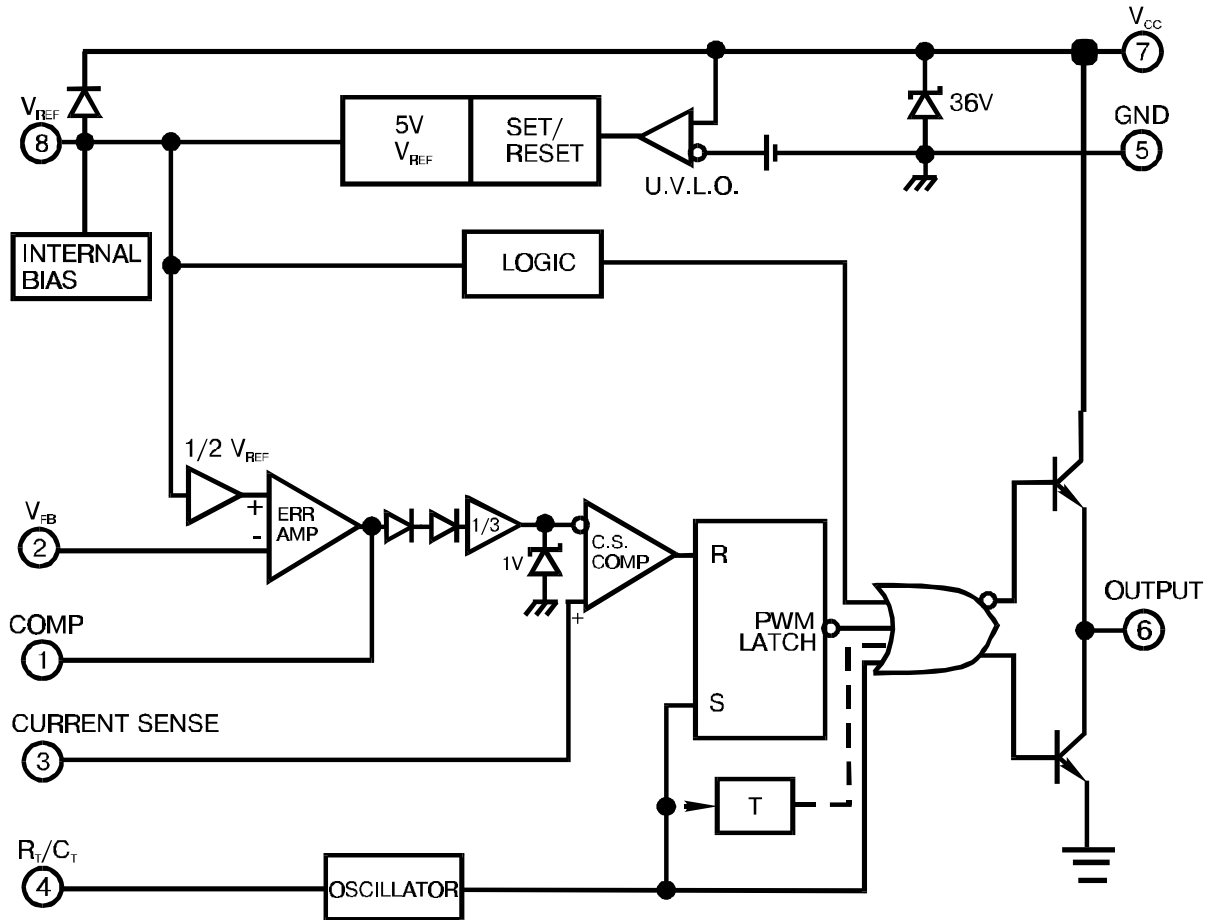

## Absolute Maximum Ratings

Characteristic	Symbol	Value	Unit
Supply Voltage	$V_{CC}$	30	V
Output Current	$I_O$	$\pm 1$	A
Analog Inputs	$V_I$	-0.3 to $V_{CC}$	V
Error Amp Output Sink Current	$I_{SINK (E.A)}$	10	mA
Power Dissipation ( $T_A=25^\circ\text{C}$ )	$P_O$	1	W



Electrical characteristics (\*V<sub>CC</sub>=15V, R<sub>T</sub>=10kΩ, C<sub>T</sub>=3.3nF, T<sub>A</sub>=0°C to +70°C, unless otherwise specified)

Characteristics	Symbol	Test Condition	Min	Typ	Max	Unit
<b>Reference Section</b>						
Reference Output Voltage	V <sub>REF</sub>	T <sub>J</sub> = 25°C, I <sub>REF</sub> = 1 mA	4.9	5.0	5.1	V
Line Regulation	ΔV <sub>REF</sub>	12V ≤ V <sub>CC</sub> ≤ 25 V		6.0	20	mV
Load Regulation	ΔV <sub>REF</sub>	1 mA ≤ I <sub>REF</sub> ≤ 20mA		6.0	25	
Short Circuit Output Current	I <sub>SC</sub>	T <sub>A</sub> = 25°C		-100	-180	mA
<b>Oscillator Section</b>						
Oscillation Frequency	f	T <sub>J</sub> = 25°C	47	52	57	KHz
Frequency Change with Voltage	Δf/ΔV <sub>CCF</sub>	12V ≤ V <sub>CC</sub> ≤ 25 V		0.05	1.0	%
Oscillator Amplitude	V <sub>(OSC)</sub>			1.6		V <sub>p-p</sub>
<b>Error Amplifier Section</b>						
Input Bias Current	I <sub>BIAS</sub>			-0.1	-2	μA
Input Voltage	V <sub>I(E.A)</sub>	V <sub>1</sub> = 2.5V	2.42	2.5	2.58	V
Open Loop Voltage Gain	G <sub>VO</sub>	2V ≤ V <sub>O</sub> ≤ 4V	65	90		dB
Power Supply Rejection Ratio	PSRR	12V ≤ V <sub>CC</sub> ≤ 25 V	60	70		
Output Sink Current	I <sub>SINK</sub>	V <sub>2</sub> = 2.7V, V <sub>1</sub> = 1.1V	2	7		mA
Output Source Current	I <sub>SOURCE</sub>	V <sub>2</sub> = 2.3V, V <sub>1</sub> = 5V	-0.5	-1.0		mA
High Output Voltage	V <sub>OH</sub>	V <sub>2</sub> = 2.3V, R <sub>L</sub> = 15KΩ to GND	5.0	6.0		V
Low Output Voltage	V <sub>OL</sub>	V <sub>2</sub> = 2.7V, R <sub>L</sub> = 15KΩ to PIN 8		0.8	1.1	
<b>Current Sense Section</b>						
Gain	G <sub>V</sub>	(Note 1 & 2)	2.85	3.0	3.15	V/V
Maximum Input Signal	V <sub>I(MAX)</sub>	V <sub>1</sub> = 5V (Note1)	0.9	1.0	1.1	V
Power Supply Rejection Ratio	PSRR	12V ≤ V <sub>CC</sub> ≤ 25 V (Note 1)		70		dB
Input Bias Current	I <sub>BIAS</sub>			-3.0	-10	μA
<b>Output Section</b>						
Low Output Voltage	V <sub>OL</sub>	I <sub>SINK</sub> = 20 mA		0.08	0.4	V
		I <sub>SINK</sub> = 200 mA		1.4	2.2	
High Output Voltage	V <sub>OH</sub>	I <sub>SINK</sub> = 20 mA	13	13.5		
		I <sub>SINK</sub> = 200 mA	12	13.0		
Rise Time	t <sub>R</sub>	T <sub>J</sub> = 25°C, C <sub>L</sub> = 1nF (Note 3)		45	150	nS
Fall Time	t <sub>F</sub>	T <sub>J</sub> = 25°C, C <sub>L</sub> = 1nF (Note 3)		35	150	
<b>Under-Voltage Lockout Section</b>						
Start Theshold	V <sub>TH(ST)</sub>		14.5	16.0	17.5	V
Min. Operating Voltage (After Turn On)	V <sub>OPR(min)</sub>		8.5	10	11.5	
<b>PWM Section</b>						
Max. Duty Cycle	D <sub>(MAX)</sub>		95	97	100	%
Min. Duty Cycle	D <sub>(MAX)</sub>				0	
<b>Total Standby Current</b>						
Start-Up Current	I <sub>ST</sub>			0.17	0.3	mA
Operating Supply Current	I <sub>CC (OPR)</sub>	V <sub>3</sub> = V <sub>2</sub> = 0V		14	17	
Zener Voltage	V <sub>Z</sub>		30	38		V

\* Adjust V<sub>CC</sub> above the start threshold before setting at 15V

Note 1: Parameter measured at trip point of I<sub>ATH</sub> with V<sub>2</sub>=0

Note 2: Gain defined as A=ΔV<sub>1</sub>/ΔV<sub>3</sub> ; 0 ≤ V<sub>3</sub> ≤ 0.8V

Note 3: These parameters, although guaranteed, are not 100% tested in production.

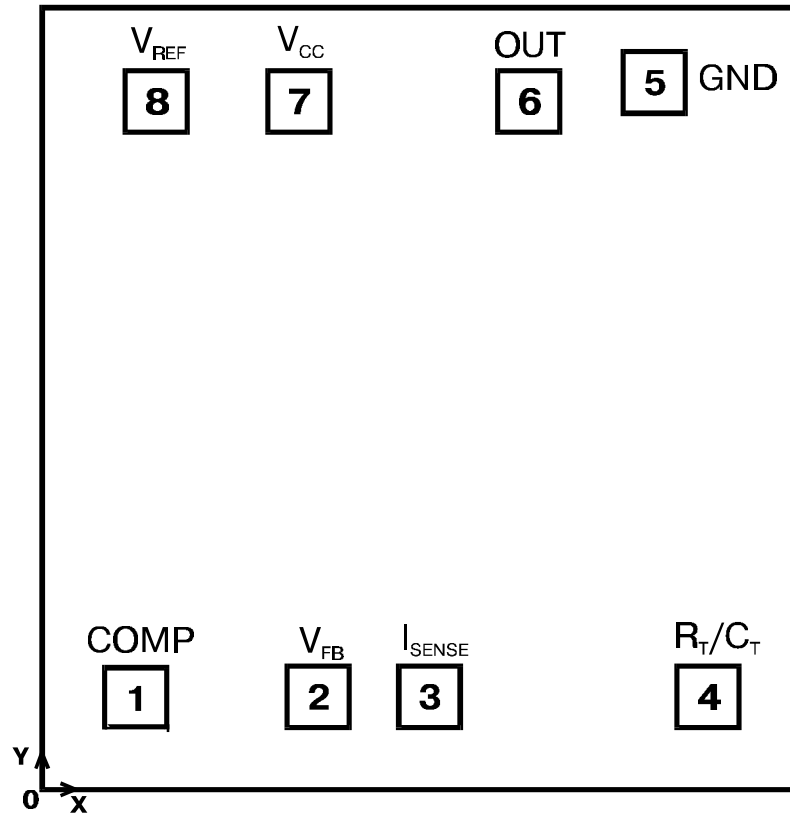
**Pad Location**

Chip size: 2.38 x 1.63 mm

Pad N	Coordinates $\mu\text{m}$		Pad N	Coordinates $\mu\text{m}$	
	X	Y		X	Y
1	90	110	5	1680	1450
2	1050	110	6	1310	1410
3	1310	110			
4	2000	150	7	815	1410
			8	460	1390

DIM.	mm			inch		
	MIN.	TYP.	MAX.	MIN.	TYP.	MAX.
A			1.75			0.069
a1	0.1		0.25	0.004		0.010
a2			1.65			0.065
a3	0.65		0.85	0.026		0.033
b	0.35		0.48	0.014		0.019
b1	0.19		0.25	0.007		0.010
C	0.25		0.5	0.010		0.020
c1	45° (typ.)					
D (1)	4.8		5.0	0.189		0.197
E	5.8		6.2	0.228		0.244
e		1.27			0.050	
e3		3.81			0.150	
F (1)	3.8		4.0	0.15		0.157
L	0.4		1.27	0.016		0.050
M			0.6			0.024
S	8° (max.)					

OUTLINE AND MECHANICAL DATA

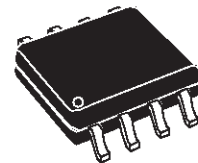

KA3842AM  
KA3842AMM

SO8

(1) D and F do not include mold flash or protrusions. Mold flash or protrusions shall not exceed 0.15mm (.006inch).

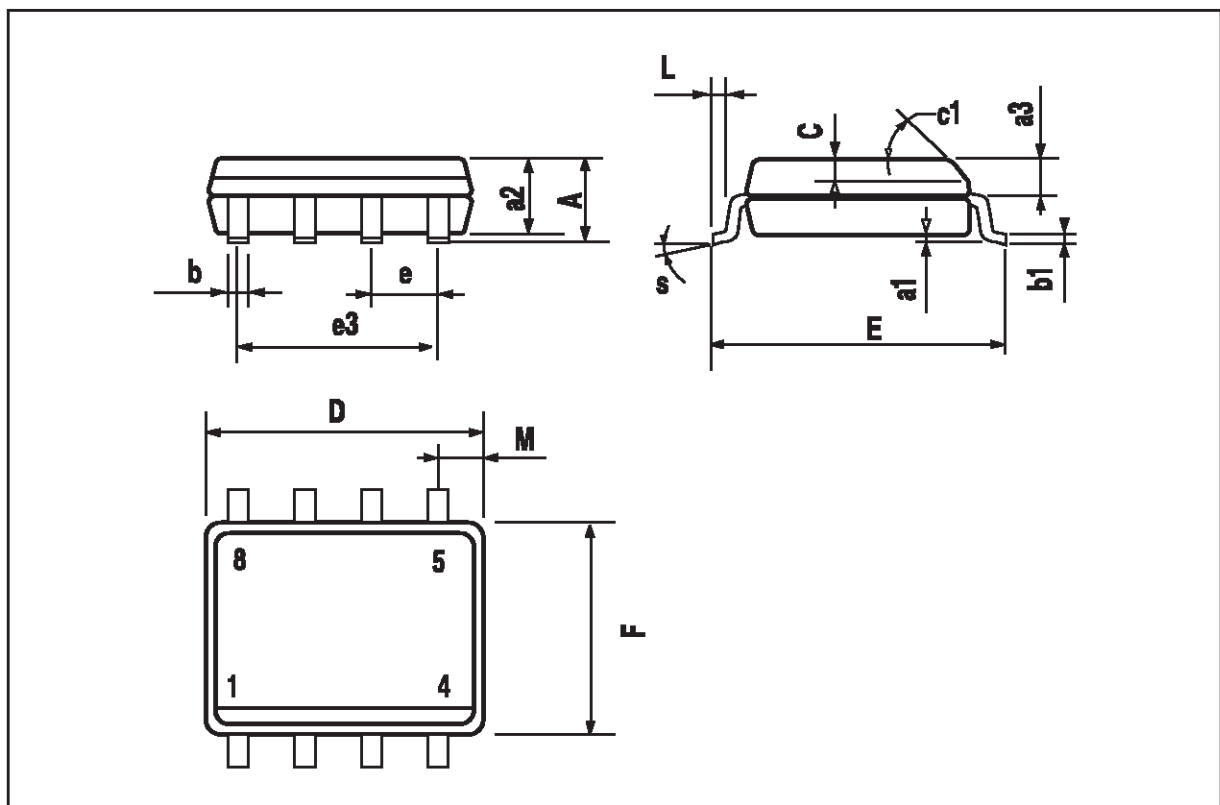

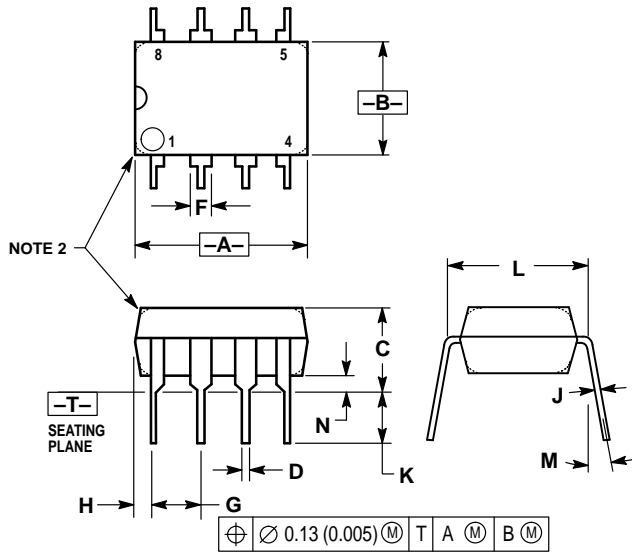

NOTES:

1. DIMENSION L TO CENTER OF LEAD WHEN FORMED PARALLEL.
2. PACKAGE CONTOUR OPTIONAL (ROUND OR SQUARE CORNERS).
3. DIMENSIONING AND TOLERANCING PER ANSI Y14.5M, 1982.

DIM	MILLIMETERS		INCHES	
	MIN	MAX	MIN	MAX
A	9.40	10.16	0.370	0.400
B	6.10	6.60	0.240	0.260
C	3.94	4.45	0.155	0.175
D	0.38	0.51	0.015	0.020
F	1.02	1.78	0.040	0.070
G	2.54 BSC		0.100 BSC	
H	0.76	1.27	0.030	0.050
J	0.20	0.30	0.008	0.012
K	2.92	3.43	0.115	0.135
L	7.62 BSC		0.300 BSC	
M	—		10°	
N	0.76	1.01	0.030	0.040

KA3842AN  
KA3842AMN

Attention: M=10°