

P.C.B LAYOUT

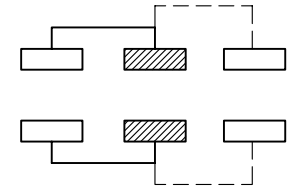

SCHEMATIC

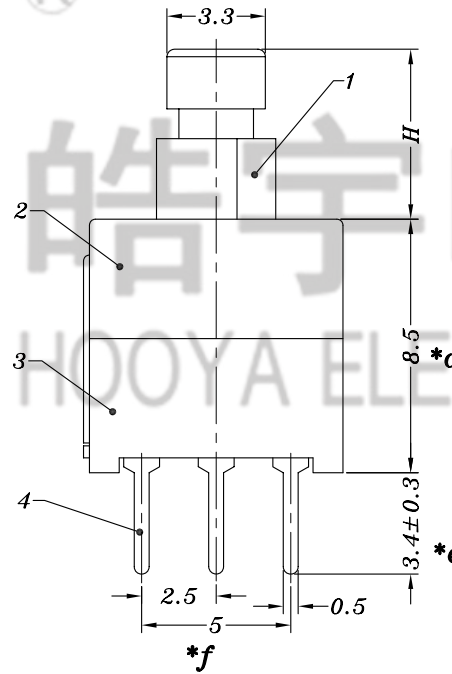
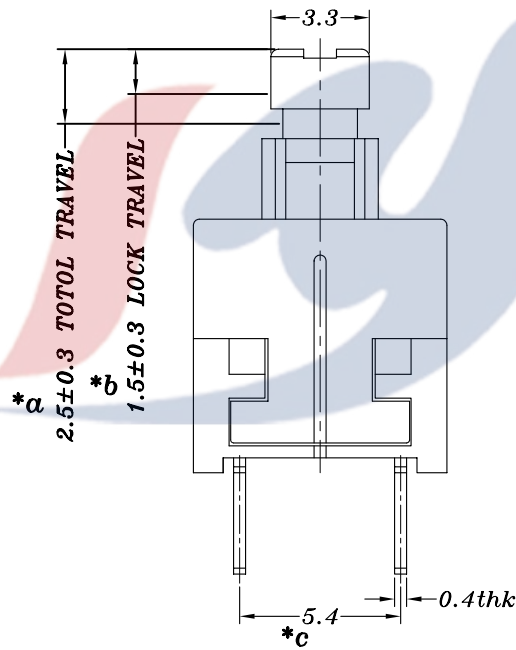

SPECIFICATION

1. Rating: DC 12V 0.3A
2. Function: 2P2T
3. Contact Resistance: $\leq 70m\Omega$ MAX
4. Operating Force: $180\pm 50gf$, $250\pm 80gf$
5. Life test: 10,000 cycles

KNOB H				C
4.5	5.7	6.5	9.0	3.3*3.3
9.5	11.25	12	14	
14.5	14.7	16		

S: 有锁
E: 力度250gf, 14C: 柄高14.0mm, C: 3.3*3.3胶头

NO.	PART NAME	MATERIAL	QTY	FINISHING	TOLERANCE UNLESS SPECIFIED		AO 2017.06.01		首次发行		GYW	
					UP TO 5mm: ± 0.1	ANGULAR $\pm 1^\circ$	NO	DATE	REVISIONS		BY	APPD
7	PB22E85 CAM STICK	SUS	1	WASHING								
6	PB22E85 SPRING	SUS	1	WASHING								
5	PB22E85 CONTACT	CLPBS	2	Ag CLAD								
4	PB22E85 TERMINAL	PA66/0.4mm BRASS	2	BLACK/Ag PLATED	TITLE: PUSH SWITCH		UNIT : MM	ROHS COMPLIANT	DWN			
3	PB22E85 CASE	PA66	1	BLACK	MODEL: PB-22E85PA-S-14C-E-W		SCALE: 5:1	CHK'D				
2	PB22E85 COVER	PA66	1	BLACK/蓝灰色								
1	PB22E85-HC KNOB	PA66	1	WHITE/YELLOW/BLACK								
					HAOYU(HONGKONG)LIMITED 皓宇(香港)有限公司				APPD			
									PRO.AGL:		REV :AO	