

**Plug-in Signal Conditioners K-UNIT**

**POTENTIOMETER TRANSMITTER**

(isolated)

**Functions & Features**

- Providing a DC output proportional to a potentiometer or slidewire position input
- Constant voltage excitation allows the connection of pots with total resistance from 100 Ω - 10 kΩ without affecting accuracy
- 50 % zero/span adjustments with minimal interaction
- Isolation up to 2000 V AC
- Fast response type available
- High-density mounting

**Typical Applications**

- Tank levels
- Positions

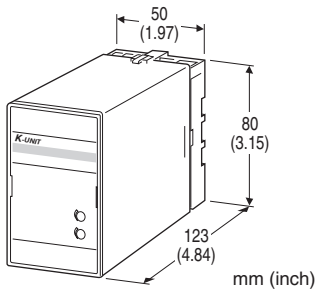

**MODEL: KMS-[1]-[2][3]**

**ORDERING INFORMATION**

- Code number: KMS-[1]-[2][3]
- Specify a code from below for each of [1] through [3]. (e.g. KMS-A-H/K/Q)
- Special output range (For codes Z & 0)
- Specify the specification for option code /Q (e.g. /C01/S01)

**INPUT POTENTIOMETER**

Total resistance 100 Ω - 10 kΩ

**[1] OUTPUT**

**Current**

- A: 4 - 20 mA DC (Load resistance 750 Ω max.)
- B: 2 - 10 mA DC (Load resistance 1500 Ω max.)
- C: 1 - 5 mA DC (Load resistance 3000 Ω max.)
- D: 0 - 20 mA DC (Load resistance 750 Ω max.)
- E: 0 - 16 mA DC (Load resistance 900 Ω max.)
- F: 0 - 10 mA DC (Load resistance 1500 Ω max.)

- G: 0 - 1 mA DC (Load resistance 15 kΩ max.)
- Z: Specify current (See OUTPUT SPECIFICATIONS)

**Voltage**

- 1: 0 - 10 mV DC (Load resistance 10 kΩ min.)
- 2: 0 - 100 mV DC (Load resistance 100 kΩ min.)
- 3: 0 - 1 V DC (Load resistance 100 Ω min.)
- 4: 0 - 10 V DC (Load resistance 1000 Ω min.)
- 5: 0 - 5 V DC (Load resistance 500 Ω min.)
- 6: 1 - 5 V DC (Load resistance 500 Ω min.)
- 4W: -10 - +10 V DC (Load resistance 2000 Ω min.)
- 5W: -5 - +5 V DC (Load resistance 1000 Ω min.)
- 0: Specify voltage (See OUTPUT SPECIFICATIONS)

**[2] POWER INPUT**

**AC Power**

- B: 100 V AC
- C: 110 V AC
- D: 115 V AC
- F: 120 V AC
- G: 200 V AC
- H: 220 V AC
- J: 240 V AC

**DC Power**

- S: 12 V DC
- R: 24 V DC

**[3] OPTIONS (multiple selections)**

**Response Time (0 - 90 %)**

- blank: Standard (≤ 0.5 sec.)
- /K: Fast Response (Approx. 25 msec.)

**Other Options**

- blank: none
- /Q: Option other than the above (specify the specification)

**SPECIFICATIONS OF OPTION: Q (multiple selections)**

**COATING (For the detail, refer to M-System's web site.)**

- /C01: Silicone coating
- /C02: Polyurethane coating
- /C03: Rubber coating

**TERMINAL SCREW MATERIAL**

- /S01: Stainless steel

**GENERAL SPECIFICATIONS**

- Construction:** Plug-in
- Connection:** M3.5 screw terminals
- Screw terminal:** Chromated steel (standard) or stainless steel
- Housing material:** Flame-resistant resin (black)
- Isolation:** Input to output to power
- Zero adjustment:** 0 - 50 % of total resistance (front)

Span adjustment: 50 - 100 % of total resistance (front)

## INPUT SPECIFICATIONS

Minimum span: 50 % of total resistance

Excitation: 0.5 V DC

## OUTPUT SPECIFICATIONS

■ DC Current: 0 - 20 mA DC

Minimum span: 1 mA

Offset: Max. 1.5 times span

Load resistance: Output drive 15 V max.

■ DC Voltage: -10 - +12 V DC

Minimum span: 5 mV

Offset: Max. 1.5 times span

Load resistance: Output drive 10 mA max.; 5 mA for negative voltage output; at  $\geq 0.5$  V

## INSTALLATION

### Power input

• AC: Operational voltage range: rating  $\pm 10$  %, 50/60  $\pm 2$  Hz, approx. 2 VA

• DC: Operational voltage range: rating  $\pm 10$  %, ripple 10 %p-p max., approx. 2 W (80 mA at 24 V)

Operating temperature: -5 to +55°C (23 to 131°F)

Operating humidity: 30 to 90 %RH (non-condensing)

Mounting: Surface or DIN rail

Weight: 300 g (0.66 lb)

## PERFORMANCE in percentage of span

Accuracy:  $\pm 0.1$  %

Temp. coefficient:  $\pm 0.02$  %/°C ( $\pm 0.01$  %/°F)

Line voltage effect:  $\pm 0.1$  % over voltage range

Insulation resistance:  $\geq 100$  M $\Omega$  with 500 V DC

Dielectric strength: 2000 V AC @1 minute (input to output to power to ground)

## EXTERNAL DIMENSIONS & TERMINAL ASSIGNMENTS unit: mm (inch)

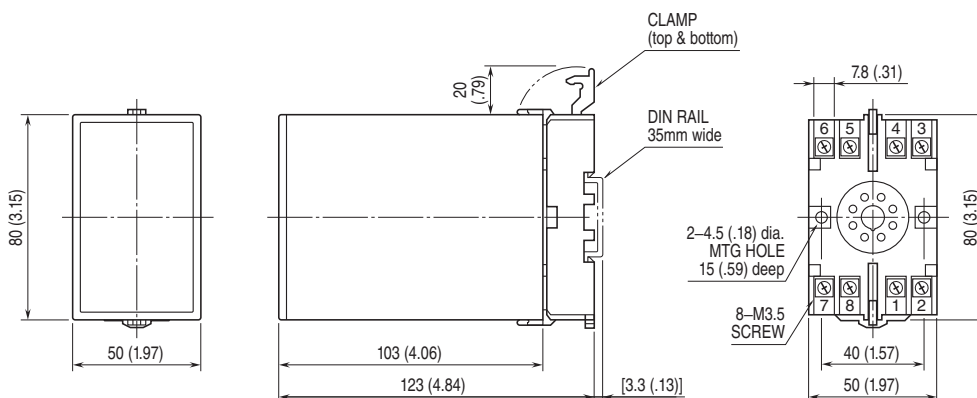

• When mounting, no extra space is needed between units.

**SCHEMATIC CIRCUITRY & CONNECTION DIAGRAM**

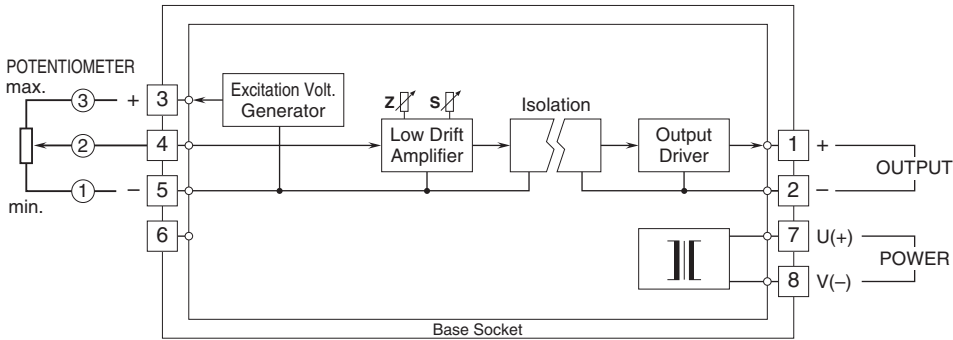

Specifications are subject to change without notice.