

## Digital Panel Meters 47 Series

### THERMOCOUPLE INPUT DIGITAL PANEL METER

(4-digit, LED display type)

#### Functions & Features

- 4-digit thermocouple input digital panel meter
- 1/8 DIN size
- Moving average function to suppress the display flickering
- Max. and Min. value display
- IP66 front panel
- Separable terminal block
- Rear terminal cover for safety strapped to the meter

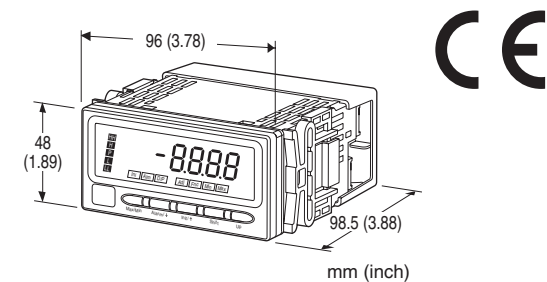

### MODEL: 47LT-1[1][2][3]-[4][5]

#### ORDERING INFORMATION

- Code number: 47LT-1[1][2][3]-[4][5]
- Specify a code from below for each of [1] through [5].  
(e.g. 47LT-101G-M2/Q)
- Specify the specification for option code /Q  
(e.g. /C01/S01/SET)

#### INPUT - Field-selectable

1: (PR), K (CA), E (CRC), J (IC), T (CC), B (RH), R, S, N

#### [1] DC OUTPUT

0: Without

##### Current

A: 4 - 20 mA DC (Load resistance 550 Ω max.)

D: 0 - 20 mA DC (Load resistance 550 Ω max.)

##### Voltage

4: 0 - 10 V DC (Load resistance 10 kΩ min.)

5: 0 - 5 V DC (Load resistance 5000 Ω min.)

6: 1 - 5 V DC (Load resistance 5000 Ω min.)

4W: -10 - +10 V DC (Load resistance 10 kΩ min.)

#### [2] ALARM OUTPUT

0: None

1: N.O. relay contact, 4 points

2: SPDT relay contact, 2 points

#### [3] DISPLAY COLOR

R: Red

YR: Orange

G: Green

BG: Bluegreen

B: Blue

W: White

#### [4] POWER INPUT

##### AC Power

M2: 100 - 240 V AC (Operational voltage range 85 - 264 V, 50/60 Hz)

##### DC Power

R: 24 V DC

(Operational voltage range 24 V ±10 %, ripple 10 %p-p max.)

P: 110 V DC

(Operational voltage range 85 - 150 V, ripple 10 %p-p max.)

#### [5] OPTIONS

blank: none

/Q: With options (specify the specification)

#### SPECIFICATIONS OF OPTION: Q (multiple selections)

##### COATING (For the detail, refer to M-System's web site.)

Moving parts and indicators are not coated.

/C01: Silicone coating

/C02: Polyurethane coating

/C03: Rubber coating

##### TERMINAL SCREW MATERIAL

/S01: Stainless steel

##### EX-FACTORY SETTING

/SET: Preset according to the Ordering Information Sheet  
(No. ESU-9512)

#### GENERAL SPECIFICATIONS

**Construction:** Panel flush mounting

**Degree of protection:** IP66; applicable to the front of the panel meter mounted according to the specified panel cutout

**Connection:** M3 separable screw terminal (torque 0.6 N·m)

**Screw terminal:** Nickel-plated steel (standard) or stainless steel

**Housing material:** Flame-resistant resin (gray)

**Isolation:** Input to DC output to HH output or H output to L output or LL output to power

**Burnout:** Upscale standard; downscale optional by programming

**Linearization:** Standard

**Cold junction compensation:** CJC sensor attached to the input terminals

**Setting:** (Front button)

- Input type
- Alarm setpoint
- Hysteresis (deadband)
- Others

(Refer to the instruction manual for details)

**Read rate:** 40 times/sec. (25 msec.)

**Averaging:** None or moving average

**Lockout setting:** Prohibiting certain operations; protecting settings

## DISPLAY

**Display:** 16 mm (.63) high, 4 digits, 7-segment LED

**Display range:** -1999 to 9999

**Minimum display/setting scale:** 1°C or 1°F (0.1°C for K and J, narrow span)

**Decimal point position:** 10<sup>-1</sup> or none (fixed depending upon the input type)

**Zero indication:** Higher-digit zeros are suppressed.

**Over-range indication:** 'S.ERR' and 'Min' or 'Max' blinking when the input signal is out of the usable range.

**Burnout indication:** 'B.ERR' blinking

**Alarm status indication**

**LL indicator:** Green turns on when the LL alarm is tripped.

**L indicator:** Green turns on when the L alarm is tripped.

**H indicator:** Red turns on when the H alarm is tripped.

**HH indicator:** Red turns on when the HH alarm is tripped.

**P indicator:** Amber turns on when none of the other alarms is tripped.

Note: Only 'P' turns on with no-alarm-output type. 'LL' or 'HH' does not turn on with dual-alarm-output type.

All setpoints can be independently set either for Hi or Lo alarm trip.

**Function indicators:**

Ini, Alm, D/P, Adj, Fnc, Min, Max

Display mode status and operation status, amber ON or blink

**Engineering unit indication:** Sticker label attached

DC, AC, mV, V, kV, μA, mA, A, kA, mW, W, kW, var, kvar, Mvar, VA, Hz, Ω, kΩ, MΩ, cm, mm, m, m/sec, mm/min, cm/min, m/min, m/h, m/s<sup>2</sup>, inch, l, l/s, l/min, l/h, m<sup>3</sup>, m<sup>3</sup>/sec, m<sup>3</sup>/min, m<sup>3</sup>/h, Nm<sup>3</sup>/h, N·m, N/m<sup>2</sup>, g, kg, kg/h, N, kN, Pa, kPa, MPa, t, t/h, °C, °F, %RH, J, kJ, MJ, rpm, sec, min, min<sup>-1</sup>, pH, %, ppm, etc.

## INPUT SPECIFICATIONS

**Input resistance:** 1 MΩ minimum

**Burnout sensing:** ≤ 0.1 μA

**Default input type:** K (CA)

## Temperature Range

THERMOCOUPLE		CONFORMANCE RANGE	USABLE RANGE
(PR)	°C	0 to 1700	-30 to +1730
	°F	32 to 3092	-22 to +3146
K (CA)	°C	-200 to +1300	-230 to +1330
	°F	-328 to +2372	-382 to +2426
K (CA), narrow span	°C	-100.0 to +450.0	-199.9 to +500.0
E (CRC)	°C	0 to 600	-30 to +630
	°F	32 to 1112	-22 to +1166
J (IC)	°C	-100 to +850	-130 to +880
	°F	-148 to +1562	-202 to +1616
J (IC), narrow span	°C	-100.0 to +350.0	-150.0 to +400.0
T (CC)	°C	-200 to +400	-230 to +430
	°F	-328 to +752	-382 to +806
B (RH)	°C	400 to 1800	70 to 1830
	°F	752 to 3272	158 to 3326
R	°C	200 to 1700	-30 to +1730
	°F	392 to 3092	-22 to +3146
S	°C	0 to 1700	-30 to +1730
	°F	32 to 3092	-22 to +3146
N	°C	-200 to +1300	-230 to +1330
	°F	-328 to +2372	-382 to +2426

## OUTPUT SPECIFICATIONS

### ■ DC Output

- DC Current

**Operational range:** -5 - +105 %

- DC Voltage

**Operational range:** -5 - +105 %

### ■ Alarm Output: Relay contact

**Rated load:** 250 V AC @ 3 A (cos φ = 1)

30 V DC @ 3 A (resistive load)

**Maximum switching voltage:** 250 V AC, 30 V DC

**Maximum switching power:** 750 VA, 90 W (resistive load)

**Minimum load:** 5 V DC @ 10 mA

**Mechanical life:** ≥ 5 × 10<sup>6</sup> cycles (rate 180 cycles/min.)

## INSTALLATION

### Power consumption

- AC: Approx. 6.5VA

- DC: Approx. 3 W

**Operating temperature:** -10 to +55°C (14 to 131°F)

**Operating humidity:** 30 to 90 %RH (non-condensing)

**Mounting:** Panel flush mounting

**Weight:** 300 g (0.66 lb)

## PERFORMANCE

### Accuracy

#### Display:

±1°C (or ±1.8°F) ±1 digit (PR, K, E, J, T)

±2°C (or ±3.6°F) ±1 digit (B, R, S, N)

**Output:**  $\pm 0.15\%$  (DC output = display + output)

**Cold junction compensation error:**

$\pm 3^{\circ}\text{C}$  at  $25 \pm 10^{\circ}\text{C}$

$\pm 5.4^{\circ}\text{F}$  at  $77 \pm 18^{\circ}\text{F}$

**Temp. coefficient:**  $\pm 0.015\%/^{\circ}\text{C}$  ( $\pm 0.008\%/^{\circ}\text{F}$ ) when the input range is set to the maximum span.

**Input resolution:** Max. 16 bits

**Output resolution:** Max. 13 bits

**Response time:**  $\leq 0.5$  sec.

(alarm output: 0 - 100 % at 90 % setpoint)

$\leq 0.5$  sec. (DC output: 0 - 90 %)

**Burnout response:**  $\leq 15$  sec.

**Line voltage effect:**  $\pm 0.1\%$  over voltage range

**Insulation resistance:**  $\geq 100$  M $\Omega$  with 500 V DC

**Dielectric strength:** 2000 V AC @ 1 minute (input to DC output to HH output or H output to L output or LL output to power to ground)

## STANDARDS & APPROVALS

**EU conformity:**

EMC Directive

EMI EN 61000-6-4

EMS EN 61000-6-2

Low Voltage Directive

EN 61010-1

Measurement Category II (alarm output)

Installation Category II (power)

Pollution degree 2

Input or DC output to alarm output to power: Reinforced insulation (300 V)

Input to DC output: Basic insulation (300 V)

RoHS Directive

**Protection against access to the terminal blocks:**

Finger protection (VDE 0660-514)

## EXTERNAL VIEW

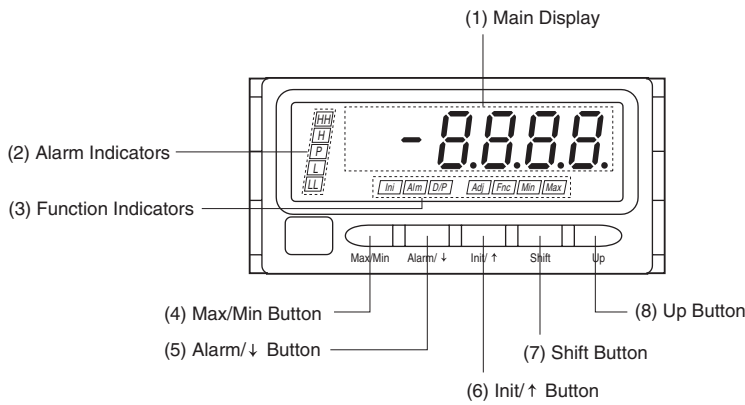

### • COMPONENT IDENTIFICATION

No.	COMPONENT	FUNCTION
(1)	Main display	Indicates present values, setting values and status of the unit.
(2)	Alarm indicators	Indicate alarm status of the input signal.
(3)	Function indicators	Indicate setting modes and status.
(4)	Max/Min button	Used to switch the main display to show present values, maximum values or minimum values etc.
(5)	Alarm/↓ button	Used to confirm alarm setting value and to move on to the alarm and other setting modes; or to shift through setting items in each setting mode.
(6)	Init/↑ button	Used to move on to the initial and other setting modes; or to shift through setting items in each setting mode.
(7)	Shift button	Used to move on to the setting standby status and shift through display digits in each setting mode.
(8)	Up button	Used to choose setting value in each setting mode.

Note: Refer to the operating manual for details on each function.

**EXTERNAL DIMENSIONS & TERMINAL ASSIGNMENTS unit: mm (inch)**

■ TOP VIEW

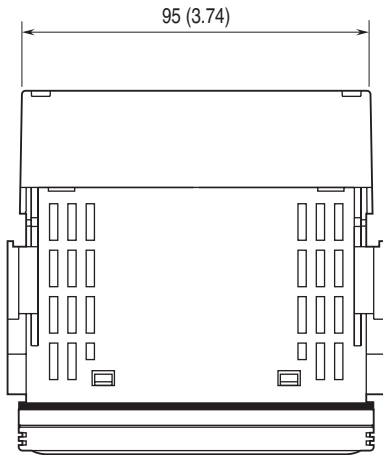

■ FRONT VIEW

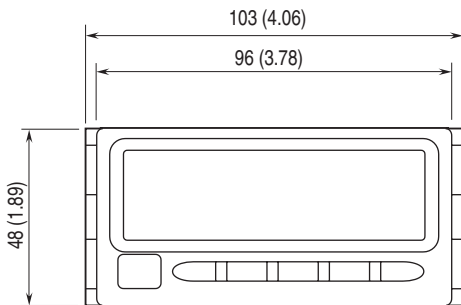

■ SIDE VIEW

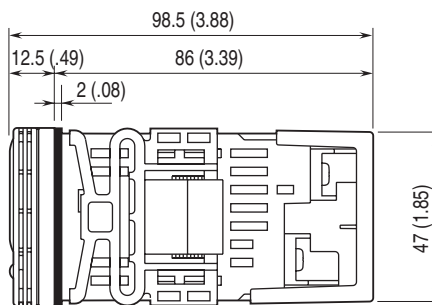

■ REAR VIEW

- No Alarm Output

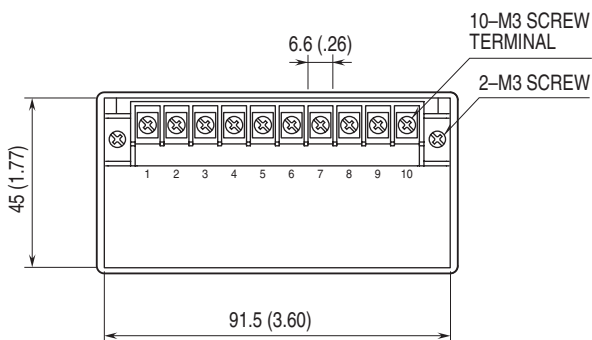

- Alarm Output

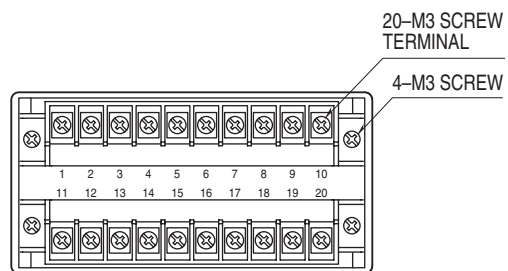

**MOUNTING REQUIREMENTS unit: mm**

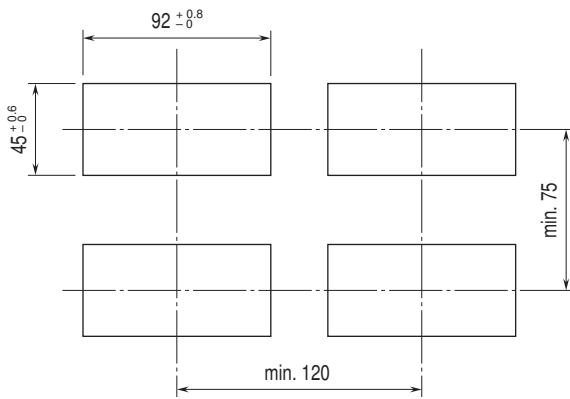

Panel thickness: 1.6 to 8.0 mm

**SCHEMATIC CIRCUITRY & CONNECTION DIAGRAM**

■ **ALARM OUTPUT CODE 0: No alarm output**

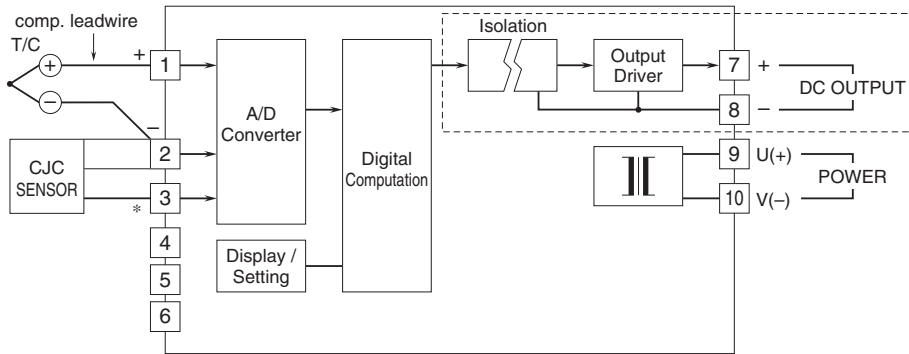

■ **ALARM OUTPUT CODE 1: N.O. contact, 4 points**

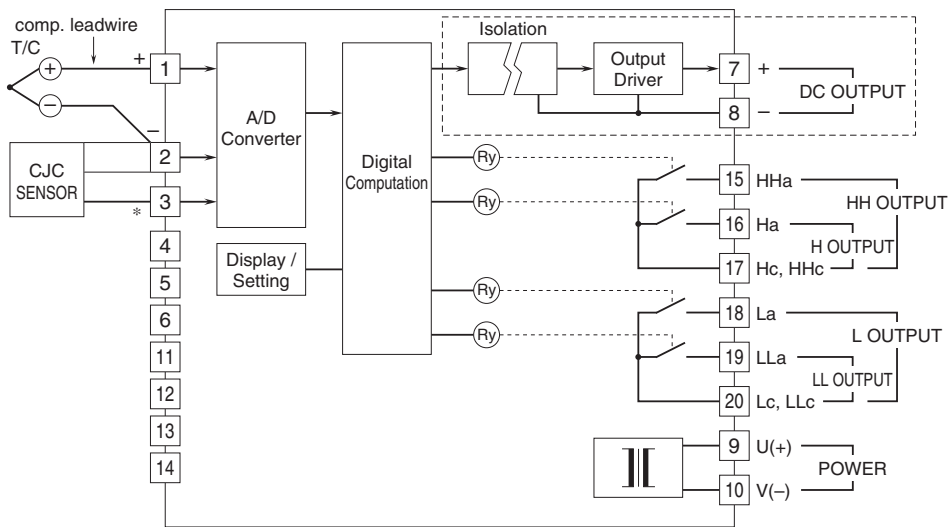

■ **ALARM OUTPUT CODE 2: SPDT contact, 2 points**

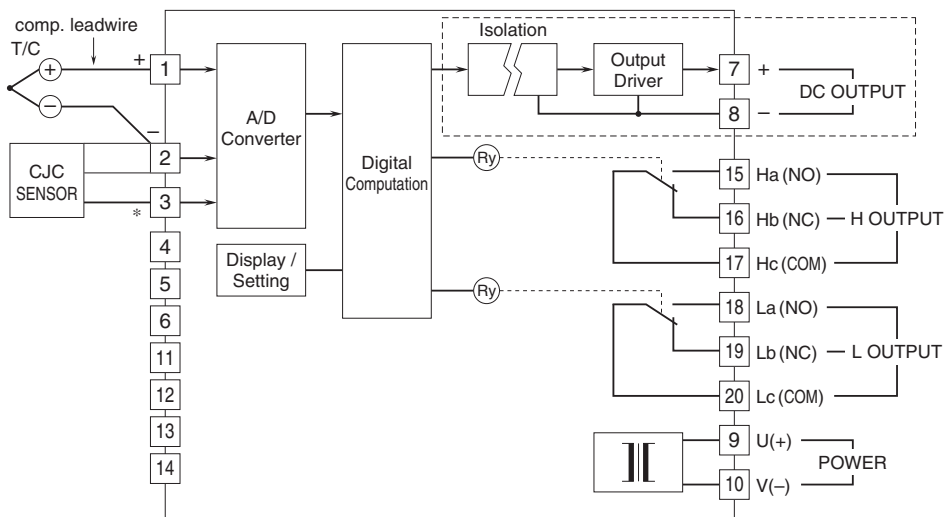

\*DO NOT loosen the screw of the terminal 3.  
Loosen only the terminals 1 – 2 when connecting extension wires.  
Note: The section enclosed by broken line is only with DC output option.

■ **Relay Protection**  
• **AC Powered**

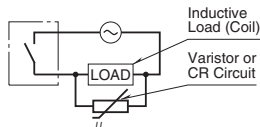

• **DC Powered**

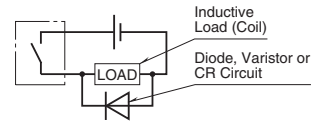



Specifications are subject to change without notice.