

REV	DESCRIPTION	BY DATE	APPD
A	ECR 7436	8/19/02	<i>[Signature]</i>

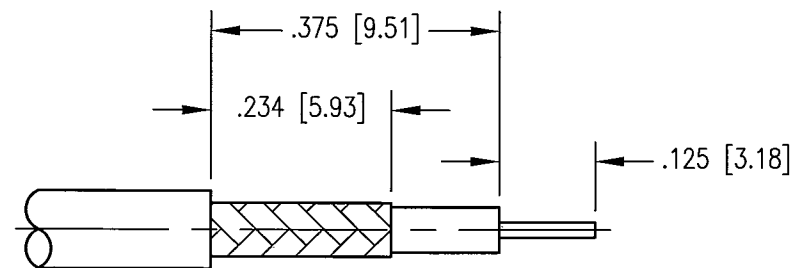
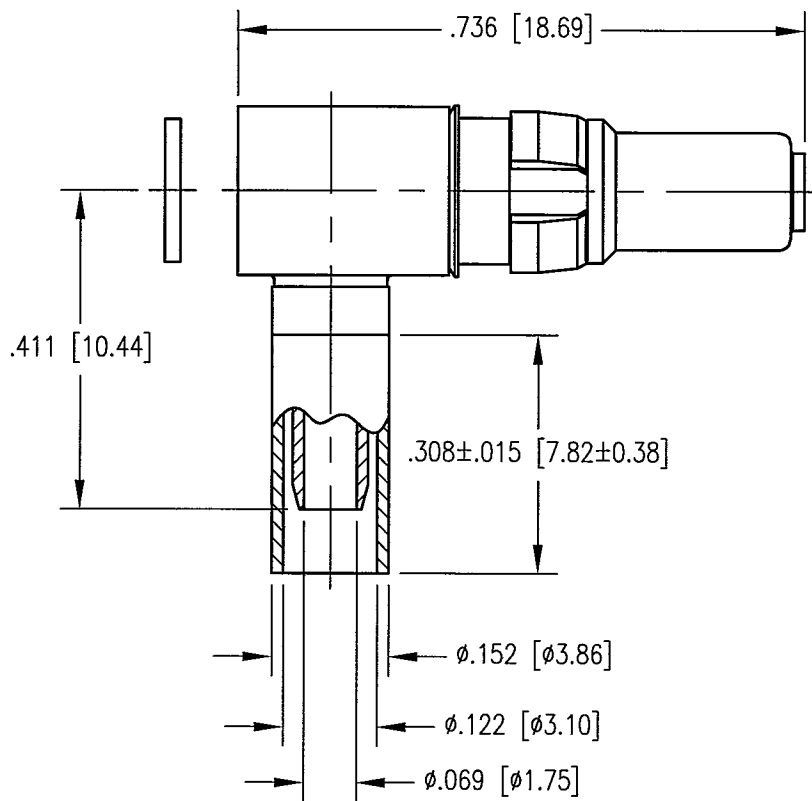

CABLE TRIMMING DIMENSIONS

NOTES:

- MATERIALS:
 CONTACT: COPPER ALLOY
 INSULATOR: TEFLON PER ASTM D1710
 CLIP RING: BERYLLIUM COPPER PER ASTM B194
 SPRING WASHER: PHOSPHOR BRONZE PER ASTM B103
 ALL OTHER METAL PARTS: BRASS PER ASTM B16
- FINISH:
 BODY AND CONTACT: .000030 MIN. GOLD PER MIL-G-45204 OVER
 .000050 MIN. NICKEL PER QQ-N-290
 CLIP RING: .000100 MIN. NICKEL PER QQ-N-290 OVER
 COPPER FLASH
 ALL OTHER METAL PARTS: .000005 MIN. GOLD PER MIL-G-45204 OVER
 .000050 MIN. NICKEL PER QQ-N-290
- FOR USE WITH RG-316 CABLE OR EQUIVALENT.
- FOR CABLING PROCEDURES USE CAP 9-02 WITH TRIMMING DIMENSIONS SHOWN.
- CRIMP FERRULE USING .128 HEX DIE.

PER ASME Y14.5M-1994 UNLESS OTHERWISE SPECIFIED: DIMENSIONS ARE IN INCHES [MM] TOLERANCES: DECIMALS .XX ± .01 [0.254] .XXX ± .005 [0.127] ANGLES ± 2° SCALE: 4:1		NORTHROP GRUMMAN Winchester Electronics 400 Park Road Watertown, CT 06795	
CUSTOMER DRAWING		TITLE RDM-HF, RIGHT ANGLE PLUG	
DRAWN CT	DATE 1/15/97	CHECKED JMC	DATE 1/15/97
APPROVED AT	DATE 1/15/97	APPROVED AT	DATE 1/15/97
A		212-910-0630G	SHT. 1 OF 1 REV. A