

FEATURES

- Mixer/Oscillator for TV Tuner
- Three-Band Local Oscillator and Mixer
- Local Oscillator Output
- 5-V Power Supply
- 24-Pin TSSOP Package

APPLICATIONS

- TV
- VCR

DESCRIPTION

The SN761685 is a monolithic IC designed for TV tuning systems. The circuit consists of a three-band local oscillator and mixer, and is available in a small outline package.

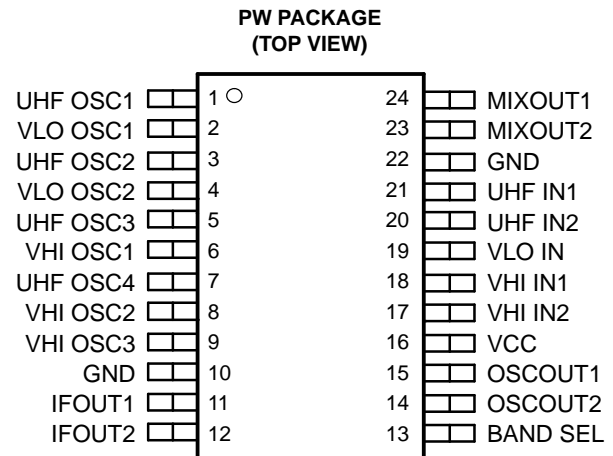

Please be aware that an important notice concerning availability, standard warranty, and use in critical applications of Texas Instruments semiconductor products and disclaimers thereto appears at the end of this data sheet.



This integrated circuit can be damaged by ESD. Texas Instruments recommends that all integrated circuits be handled with appropriate precautions. Failure to observe proper handling and installation procedures can cause damage.

UHF IN1 and UHF IN2 (pins 20 and 21) withstand 1 kV, and all other pins withstand 2 kV, according to the human body model (1.5 kΩ, 100 pF).

Functional Block Diagram

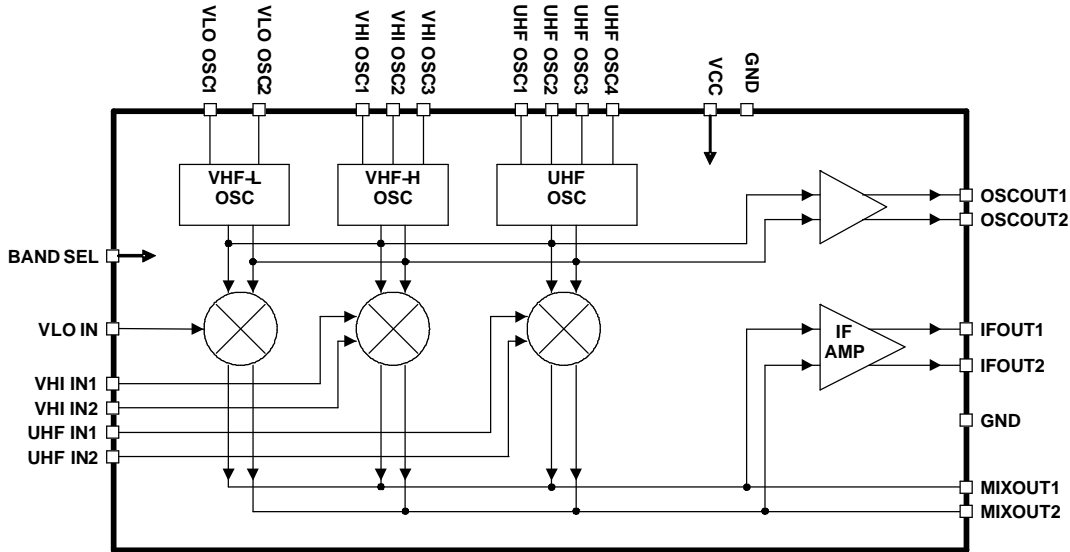

Pin Assignments

Pin Description

TERMINAL NAME		NO.	DESCRIPTION	SCHEMATIC
BAND SEL	13	Band selection input	Figure 1	
GND	10, 22	Ground		
IF OUT1	11	IF amplifier output 1	Figure 2	
IF OUT2	12	IF amplifier output 2	Figure 2	
MIXOUT1	24	Mixer output 1	Figure 3	
MIXOUT2	23	Mixer output 2	Figure 3	
OSCOUT1	15	Local oscillator output 1	Figure 4	
OSCOUT2	14	Local oscillator output 2	Figure 4	
UHF IN1	21	UHF mixer input 1	Figure 5	
UHF IN2	20	UHF mixer input 2	Figure 5	
UHF OSC 1	1	UHF oscillator 1	Figure 6	
UHF OSC 2	3	UHF oscillator 2	Figure 6	
UHF OSC 3	5	UHF oscillator 3	Figure 6	
UHF OSC 4	7	UHF oscillator 4	Figure 6	
VCC	16	VCC 5 V		
VHI IN1	18	VHF HIGH mixer input 1	Figure 7	
VHI IN2	17	VHF HIGH mixer input 2	Figure 7	
VHI OSC 1	6	VHF HIGH oscillator 1	Figure 8	
VHI OSC 2	8	VHF HIGH oscillator 2	Figure 8	
VHI OSC 3	9	VHF HIGH oscillator 3	Figure 8	
VLO IN	19	VHF LOW mixer input	Figure 9	

Pin Assignments (continued)
Pin Description (continued)

TERMINAL NAME		NO.	DESCRIPTION	SCHEMATIC
VLO OSC 1		2	VHF LOW oscillator 1	Figure 10
VLO OSC 2		4	VHF LOW oscillator 2	Figure 10

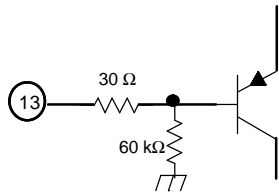

Figure 1.

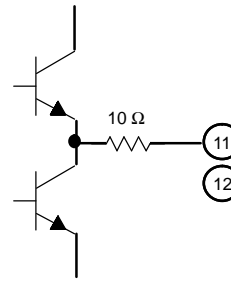

Figure 2.

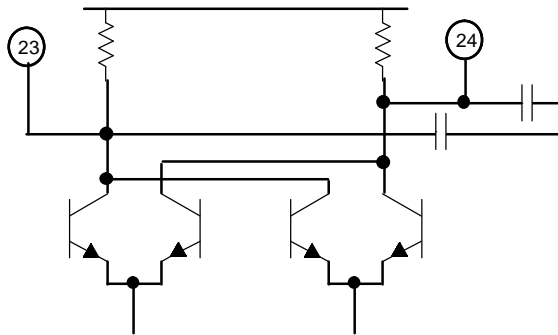

Figure 3.

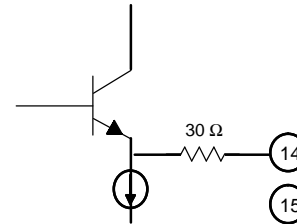

Figure 4.

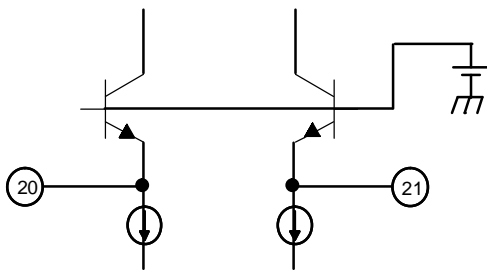

Figure 5.

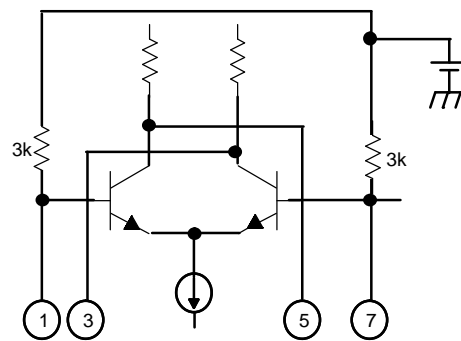

Figure 6.

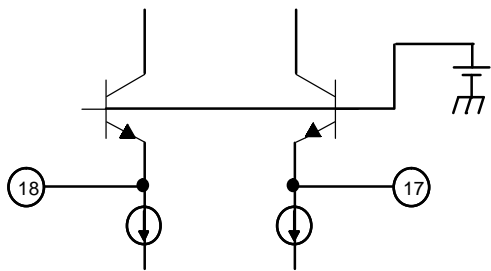

Figure 7.

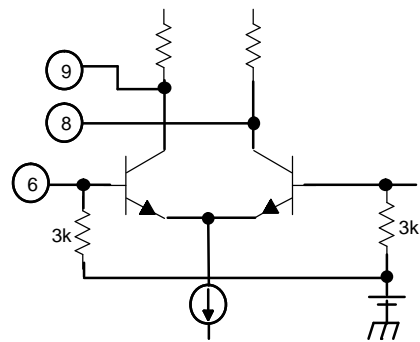

Figure 8.

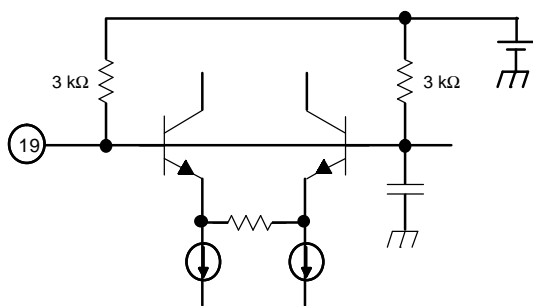

Figure 9.

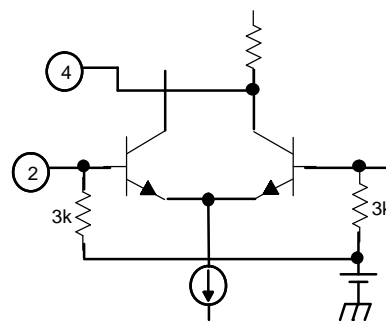

Figure 10.

ABSOLUTE MAXIMUM RATINGS

over operating free-air temperature range (unless otherwise noted) ⁽¹⁾

Supply voltage, V_{CC} ⁽²⁾	VCC (Pin 16)	–0.4 V to 6.5 V
Input voltage ⁽²⁾	V_{IN} (Pins 1–9, 11–15, 17–21, 23, 24)	–0.4 V to 6.5 V
Continuous total dissipation, P_D ⁽³⁾	$T_A \leq 25^\circ\text{C}$	1092 mW
Storage temperature range, T_{stg}		–65°C to 150°C
Maximum junction temperature, T_J		150°C
Maximum short-circuit time, $t_{SC(max)}$	Each pin to V_{CC} or to GND	10 s

(1) Stresses beyond those listed under "absolute maximum ratings" may cause permanent damage to the device. These are stress ratings only, and functional operation of the device at these or any other conditions beyond those indicated under "recommended operating conditions" is not implied. Exposure to absolute-maximum-rated conditions for extended periods may affect device reliability.

(2) Voltage values are with respect to the IF GND of the circuit.

(3) Derating factor is 8.73 mW/°C for $T_A \geq 25^\circ\text{C}$.

RECOMMENDED OPERATING CONDITIONS

over operating free-air temperature range (unless otherwise noted)

	MIN	NOM	MAX	UNIT
Supply voltage, V_{CC}	4.5	5	5.5	V
Operating free-air temperature, T_A	–20		85	°C

ELECTRICAL CHARACTERISTICS, DC Parameters

$V_{CC} = 5\text{ V}$, $T_A = 25^\circ\text{C}$, unless otherwise noted

PARAMETER		TEST CONDITIONS	MIN	TYP	MAX	UNIT
I_{CC}	Supply current	VHF-LOW band, no signal		43		mA
V_{SEL1}	Voltage on band selection (BAND SEL)	VHF-LOW band	0		$0.18 V_{CC}$	V
V_{SEL2}		VHF-HIGH band	$0.26 V_{CC}$		$0.47 V_{CC}$	
V_{SEL3}		UHF band	$0.55 V_{CC}$		V_{CC}	
I_{SEL}	Input current (BAND SEL)	$V_{SEL} = 5\text{ V}$			130	μA

ELECTRICAL CHARACTERISTICS, AC Parameters

$V_{CC} = 5\text{ V}$, $T_A = 25^\circ\text{C}$, measured in reference measurement circuit of 50- Ω system, IF filter characteristics: $f_{PEAK} = 36\text{ MHz}$, unless otherwise noted

PARAMETER		TEST CONDITIONS	MIN	TYP	MAX	UNIT
G_{c1}	Conversion gain, VHF-LOW ⁽¹⁾	$f_{IN} = 50\text{ MHz}$	22	25	28	dB
G_{c3}		$f_{IN} = 170\text{ MHz}$	22	25	28	
G_{c4}	Conversion gain, VHF-HIGH ⁽²⁾	$f_{IN} = 170\text{ MHz}$	21	24	27	dB
G_{c6}		$f_{IN} = 450\text{ MHz}$	21	24	27	
G_{c7}	Conversion gain, VHF-UHF ⁽²⁾	$f_{IN} = 450\text{ MHz}$	21	24	27	dB
G_{c9}		$f_{IN} = 860\text{ MHz}$	21	24	27	
NF_1	Noise figure, VHF-LOW (see Figure 14)	$f_{IN} = 50\text{ MHz}$		9.5		dB
NF_3		$f_{IN} = 170\text{ MHz}$		9.5		
NF_4	Noise figure, VHF-HIGH (see Figure 15)	$f_{IN} = 170\text{ MHz}$		12		dB
NF_6		$f_{IN} = 450\text{ MHz}$		12		
NF_7	Noise figure, UHF (see Figure 15)	$f_{IN} = 450\text{ MHz}$		11		dB
NF_9		$f_{IN} = 860\text{ MHz}$		11		
CM_1	1% cross-modulation, VHF-LOW ⁽³⁾	$f_{IN} = 50\text{ MHz}$		88		dB μ V
CM_3		$f_{IN} = 170\text{ MHz}$		90		
CM_4	1% cross-modulation, VHF-HIGH ⁽⁴⁾	$f_{IN} = 170\text{ MHz}$		84		dB μ V
CM_6		$f_{IN} = 450\text{ MHz}$		84		
CM_7	1% cross-modulation, UHF ⁽⁴⁾	$f_{IN} = 450\text{ MHz}$		85		dB μ V
CM_9		$f_{IN} = 860\text{ MHz}$		85		
V_{IFO1}	IF output voltage, VHF-LOW ⁽⁵⁾	$f_{IN} = 50\text{ MHz}$		117		dB μ V
V_{IFO3}		$f_{IN} = 170\text{ MHz}$		117		
V_{IFO4}	IF output voltage, VHF-HIGH ⁽⁶⁾	$f_{IN} = 170\text{ MHz}$		117		dB μ V
V_{IFO6}		$f_{IN} = 450\text{ MHz}$		117		
V_{IFO7}	IF output voltage, UHF ⁽⁶⁾	$f_{IN} = 450\text{ MHz}$		117		dB μ V
V_{IFO9}		$f_{IN} = 860\text{ MHz}$		117		
Δf_{SWO1}	SW ON drift, VHF-LOW ⁽⁷⁾	$f_{OSC} = 86\text{ MHz}$			± 300	kHz
Δf_{SWO3}		$f_{OSC} = 206\text{ MHz}$			± 400	
Δf_{SWO4}	SW ON drift, VHF-HIGH ⁽⁷⁾	$f_{OSC} = 206\text{ MHz}$			± 300	kHz
Δf_{SWO6}		$f_{OSC} = 486\text{ MHz}$			± 400	
Δf_{SWO7}	SW ON drift, UHF ⁽⁷⁾	$f_{OSC} = 486\text{ MHz}$			± 400	kHz
Δf_{SWO9}		$f_{OSC} = 896\text{ MHz}$			± 500	
Δf_{VSO1}	Frequency sift on V_{CC} , VHF-LOW (NOTE13)	$f_{OSC} = 86\text{ MHz}$			± 150	kHz
Δf_{VSO3}		$f_{OSC} = 206\text{ MHz}$			± 250	
Δf_{VSO4}	Frequency sift on V_{CC} , VHF-HIGH ⁽⁸⁾	$f_{OSC} = 206\text{ MHz}$			± 150	kHz
Δf_{VSO6}		$f_{OSC} = 486\text{ MHz}$			± 250	
Δf_{VSO7}	Frequency sift on V_{CC} , UHF ⁽⁸⁾	$f_{OSC} = 486\text{ MHz}$			± 150	kHz
Δf_{VSO9}		$f_{OSC} = 896\text{ MHz}$			± 250	

- (1) IF = 36 MHz, $V_{IN} = 70\text{ dB}\mu\text{V}$ (see [Figure 12](#)).
- (2) IF = 36 MHz, $V_{IN} = 70\text{ dB}\mu\text{V}$ (see [Figure 13](#)).
- (3) DES: $V_{IN} = 80\text{ dB}\mu\text{V}$, UNDES: $f_{des} \pm 6\text{ MHz}$, AM 1 kHz, 30%, DES/CM = S/I = 46 dB (see [Figure 16](#)).
- (4) DES: $V_{IN} = 80\text{ dB}\mu\text{V}$, UNDES: $f_{des} \pm 6\text{ MHz}$ AM 1 kHz 30%, DES/CM = S/I = 46 dB (see [Figure 17](#)).
- (5) IF = 36 MHz, $V_{IN} = 107\text{ dB}\mu\text{V}$ (see [Figure 18](#)).
- (6) IF = 36 MHz, $V_{IN} = 107\text{ dB}\mu\text{V}$, (see [Figure 19](#)).
- (7) Delta frequency from 3 s to 3 min after switch on
- (8) Delta frequency when $V_{CC} = 5\text{ V}$ changes $\pm 10\%$

APPLICATION INFORMATION

Reference Measurement Circuit

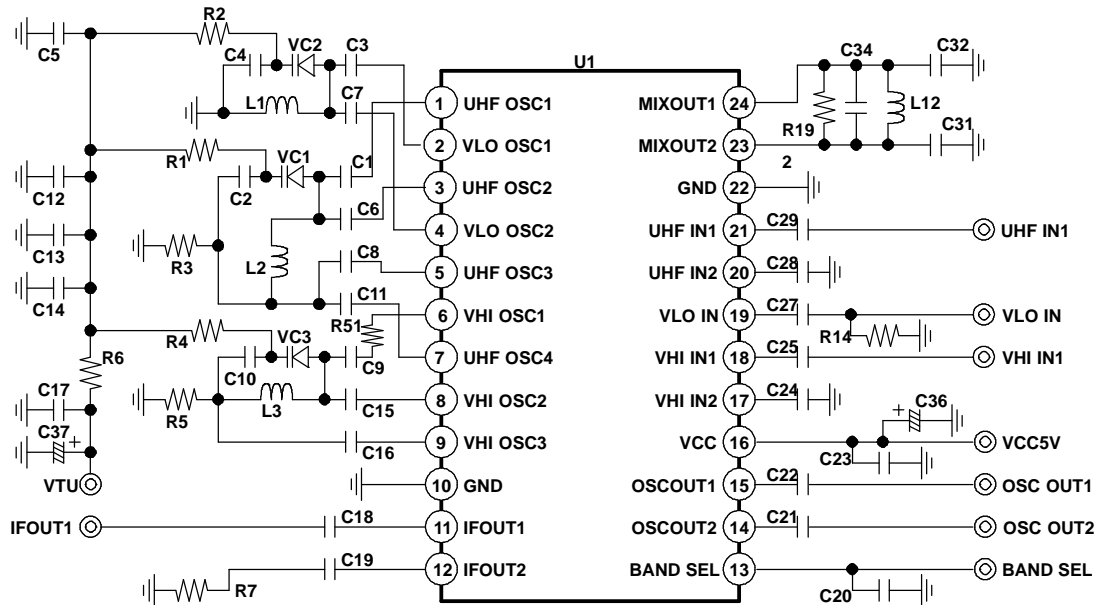

NOTE: This application information is advisory, and a performance check is required for actual application circuits. TI assumes no responsibility for the consequences of the use of this circuit, such as an infringement of intellectual property rights or other rights, including patents, of third parties.

Figure 11. Reference Measurement Circuit

APPLICATION INFORMATION (continued)
Component Values for Measurement Circuit

PART NAME	VALUE	PART NAME	VALUE
C1 (UHF OSC)	2 pF	C28 (UHF IN2)	2.2 nF
C2 (UHF OSC)	15 pF	C29 (UHF IN1)	2.2 nF
C3 (VLO OSC)	1.5 pF	C31 (MIXOUT)	Open
C4 (VLO OSC)	120 pF	C32 (MIXOUT)	Open
C5 (VTU)	Open	C34 (MIXOUT)	15 pF
C6 (UHF OSC)	1.5 pF	C36 (VCC)	47 μF
C7 (VLO OSC)	2 pF	C37 (VTU)	47 μF/50 V
C8 (UHF OSC)	1.5 pF	L1 (VHI OSC)	φ3 mm, 8T, wire 0,32 mm
C9 (VHI OSC)	3 pF	L2 (UHF OSC)	φ1.8 mm, 2T, wire 0,4 mm
C10 (VHI OSC)	91 pF	L3 (VHI OSC)	φ2 mm, 4T, wire 0,4 mm
C11 (UHF OSC)	2 pF	L12 (MIXOUT)	φ3 mm, 25T, wire 0,29 mm
C12 (VTU)	2.2 nF	R1(UHF OSC)	22 kΩ
C13 (VTU)	2.2 nF	R2 (VLO OSC)	33 kΩ
C14 (VTU)	2.2 nF	R3 (UHF OSC)	22 kΩ
C15 (VHI OSC)	3 pF	R4 (VHI OSC)	33 kΩ
C16 (VHI OSC)	Open	R5 (VHI OSC)	0 Ω
C17 (VTU)	1 μF/50 V	R6 (VTU)	22 kΩ
C18 (IF OUT1)	2.2 nF	R7 (IFOUT2)	50 Ω
C19 (IF OUT2)	2.2 nF	R14 (VLO IN)	Open or 50 Ω
C20 (BAND SEL)	0.1 μF	R19 (MIXOUT)	Open
C21 (OSC OUT2)	2.2 nF	R51 (VHI OSC)	0 Ω
C22 (OSC OUT1)	2.2 nF	U1	SN761685
C23 (VCC)	0.1 μF	VC1 (UHF OSC)	1T363A
C24 (VHI IN2)	2.2 nF	VC2 (VLO OSC)	1T363A
C25 (VHI IN1)	2.2 nF	VC3 (VHI OSC)	1T363A
C27 (VLO IN)	2.2 nF		

Test Circuits

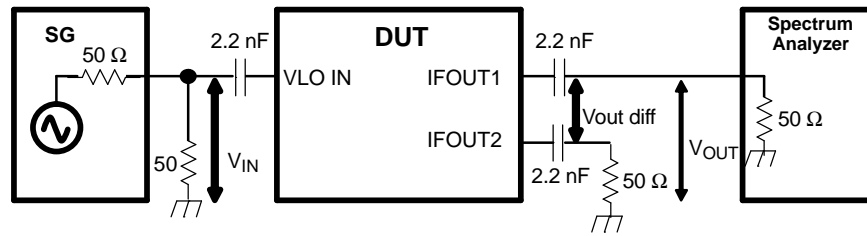

$$GC = 20\log(V_{out\ diff} / V_{IN}) = 20\log(V_{OUT} / V_{IN}) + 6$$

Figure 12. VHF-L Conversion Gain-Measurement Circuit

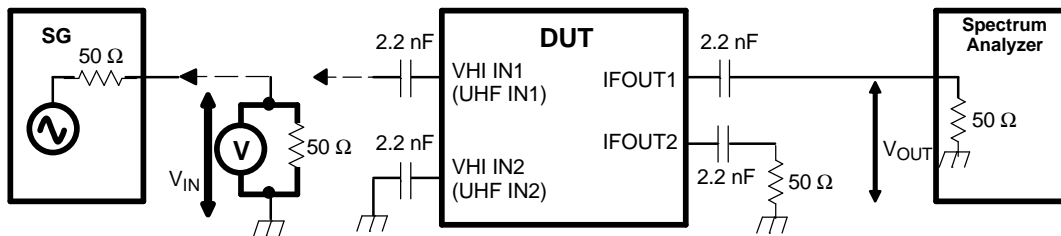

$$GC = 20\log(V_{out} / V_{IN})$$

Input: No Matching

Figure 13. VHF-H, UHF-Conversion Gain-Measurement Circuit

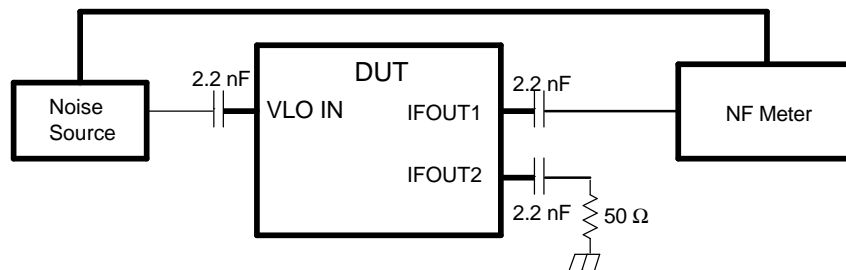

Figure 14. VHF-L Noise-Figure Measurement Circuit

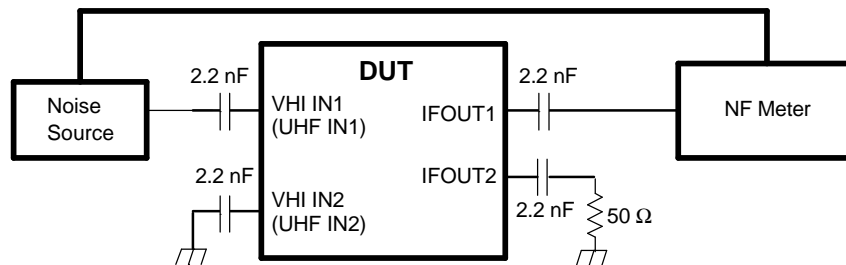

Figure 15. VHF-H, UHF Noise-Figure Measurement Circuit

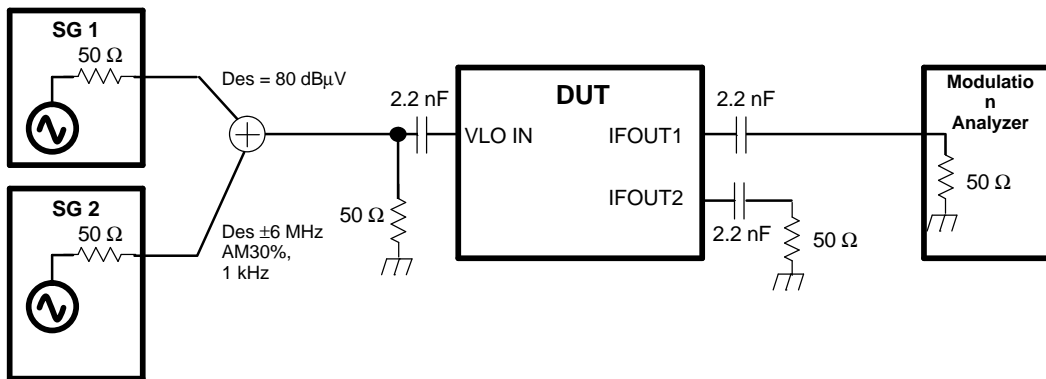

Figure 16. VHF-L 1% Cross-Modulation Distortion Measurement Circuit

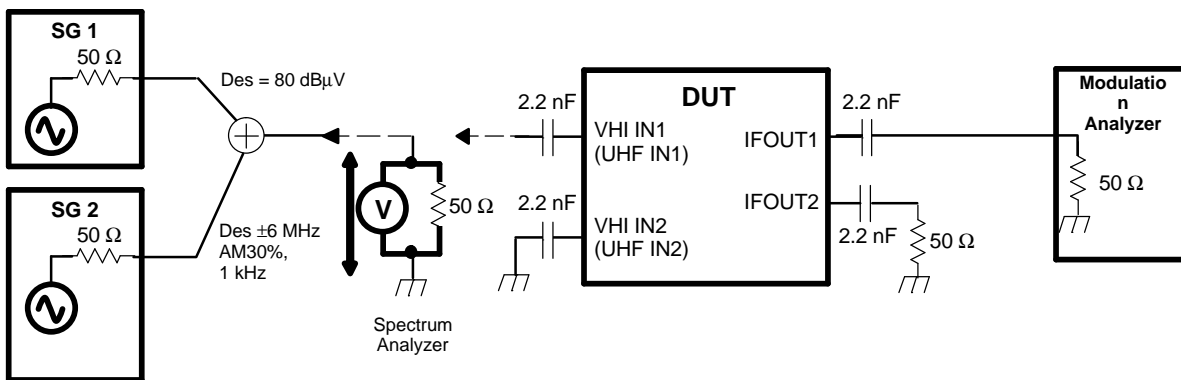

Figure 17. VHF-L 1% Cross-Modulation Distortion Measurement Circuit

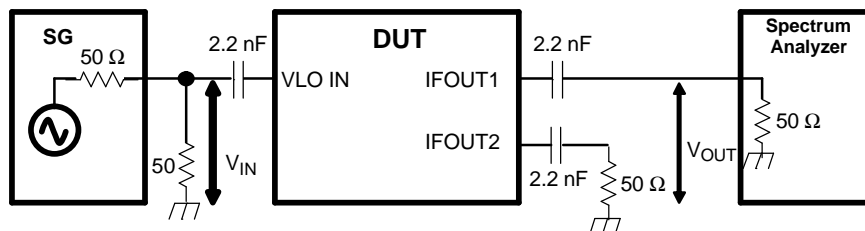

Figure 18. VHF-L Output Voltage Measurement Circuit

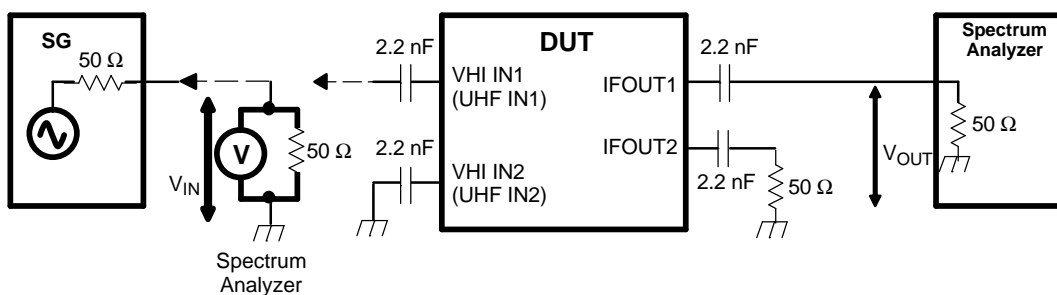

Figure 19. VHF-H, UHF Output Voltage Measurement Circuit

TYPICAL CHARACTERISTICS

S-Parameter

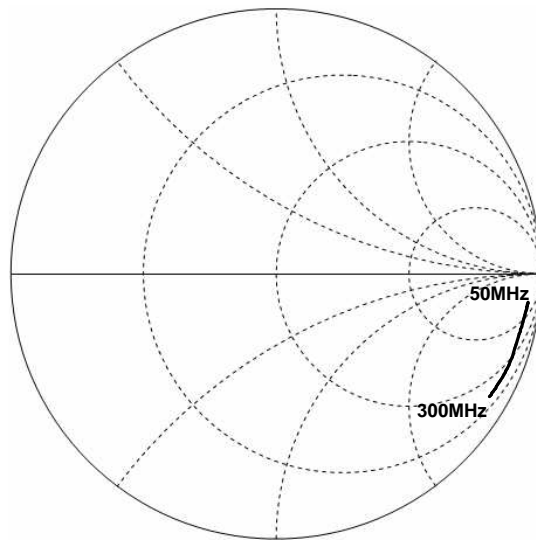

Figure 20. VLO IN

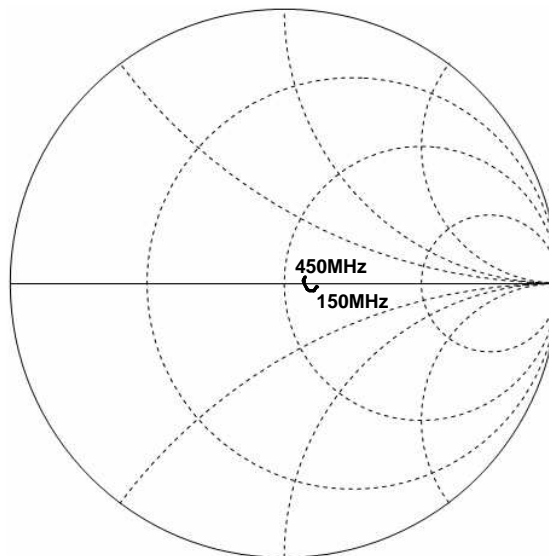

Figure 21. VH IN1,2

TYPICAL CHARACTERISTICS (continued)

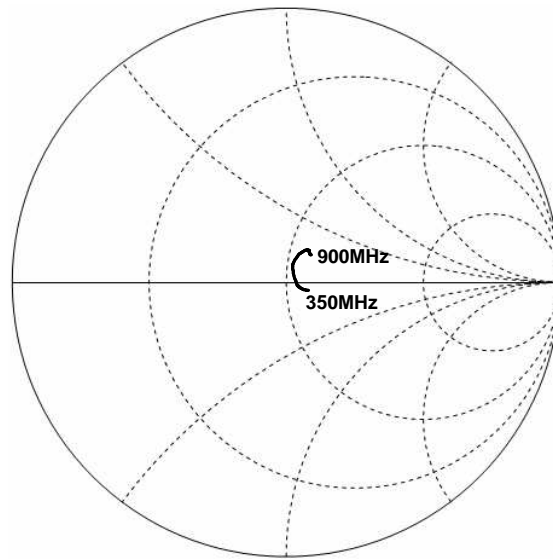

Figure 22. UHF IN1,2

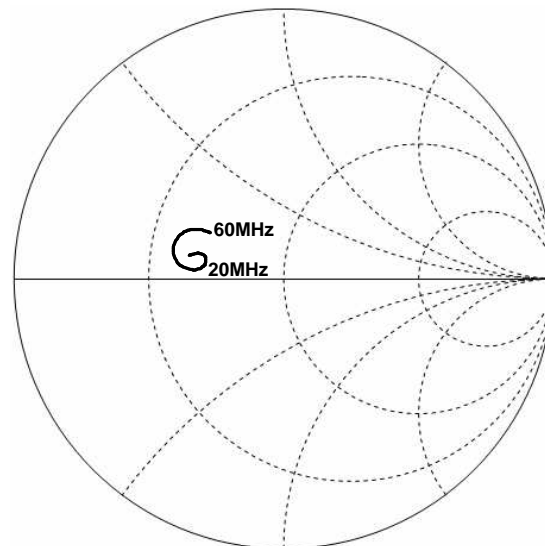
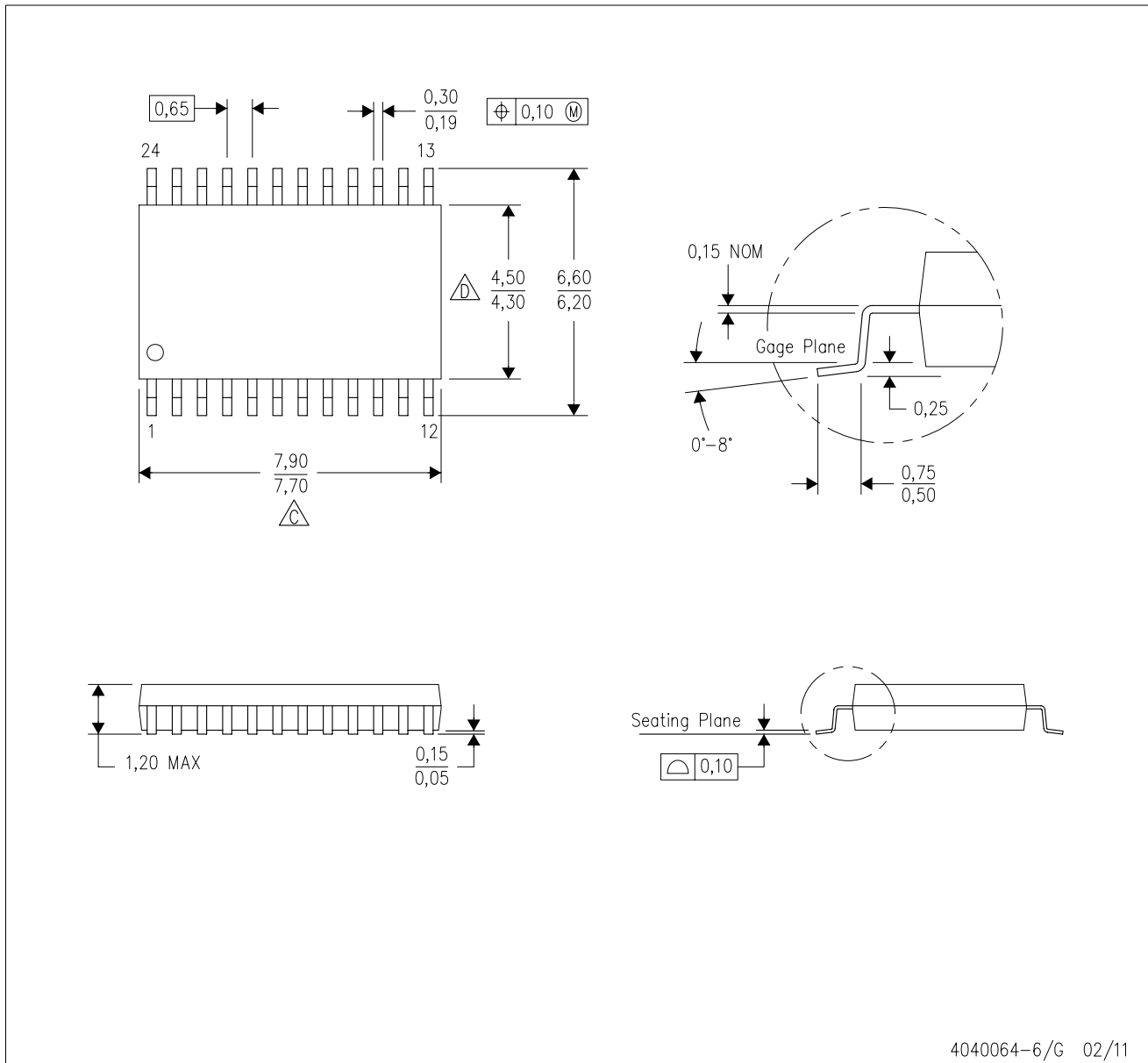

Figure 23. IFOUT1,2

PW (R-PDSO-G24)

PLASTIC SMALL OUTLINE



4040064-6/G 02/11

- NOTES:
- A. All linear dimensions are in millimeters. Dimensioning and tolerancing per ASME Y14.5M-1994.
 - B. This drawing is subject to change without notice.
 - C. Body length does not include mold flash, protrusions, or gate burrs. Mold flash, protrusions, or gate burrs shall not exceed 0,15 each side.
 - D. Body width does not include interlead flash. Interlead flash shall not exceed 0,25 each side.
 - E. Falls within JEDEC MO-153

IMPORTANT NOTICE

Texas Instruments Incorporated and its subsidiaries (TI) reserve the right to make corrections, enhancements, improvements and other changes to its semiconductor products and services per JESD46, latest issue, and to discontinue any product or service per JESD48, latest issue. Buyers should obtain the latest relevant information before placing orders and should verify that such information is current and complete. All semiconductor products (also referred to herein as "components") are sold subject to TI's terms and conditions of sale supplied at the time of order acknowledgment.

TI warrants performance of its components to the specifications applicable at the time of sale, in accordance with the warranty in TI's terms and conditions of sale of semiconductor products. Testing and other quality control techniques are used to the extent TI deems necessary to support this warranty. Except where mandated by applicable law, testing of all parameters of each component is not necessarily performed.

TI assumes no liability for applications assistance or the design of Buyers' products. Buyers are responsible for their products and applications using TI components. To minimize the risks associated with Buyers' products and applications, Buyers should provide adequate design and operating safeguards.

TI does not warrant or represent that any license, either express or implied, is granted under any patent right, copyright, mask work right, or other intellectual property right relating to any combination, machine, or process in which TI components or services are used. Information published by TI regarding third-party products or services does not constitute a license to use such products or services or a warranty or endorsement thereof. Use of such information may require a license from a third party under the patents or other intellectual property of the third party, or a license from TI under the patents or other intellectual property of TI.

Reproduction of significant portions of TI information in TI data books or data sheets is permissible only if reproduction is without alteration and is accompanied by all associated warranties, conditions, limitations, and notices. TI is not responsible or liable for such altered documentation. Information of third parties may be subject to additional restrictions.

Resale of TI components or services with statements different from or beyond the parameters stated by TI for that component or service voids all express and any implied warranties for the associated TI component or service and is an unfair and deceptive business practice. TI is not responsible or liable for any such statements.

Buyer acknowledges and agrees that it is solely responsible for compliance with all legal, regulatory and safety-related requirements concerning its products, and any use of TI components in its applications, notwithstanding any applications-related information or support that may be provided by TI. Buyer represents and agrees that it has all the necessary expertise to create and implement safeguards which anticipate dangerous consequences of failures, monitor failures and their consequences, lessen the likelihood of failures that might cause harm and take appropriate remedial actions. Buyer will fully indemnify TI and its representatives against any damages arising out of the use of any TI components in safety-critical applications.

In some cases, TI components may be promoted specifically to facilitate safety-related applications. With such components, TI's goal is to help enable customers to design and create their own end-product solutions that meet applicable functional safety standards and requirements. Nonetheless, such components are subject to these terms.

No TI components are authorized for use in FDA Class III (or similar life-critical medical equipment) unless authorized officers of the parties have executed a special agreement specifically governing such use.

Only those TI components which TI has specifically designated as military grade or "enhanced plastic" are designed and intended for use in military/aerospace applications or environments. Buyer acknowledges and agrees that any military or aerospace use of TI components which have **not** been so designated is solely at the Buyer's risk, and that Buyer is solely responsible for compliance with all legal and regulatory requirements in connection with such use.

TI has specifically designated certain components as meeting ISO/TS16949 requirements, mainly for automotive use. In any case of use of non-designated products, TI will not be responsible for any failure to meet ISO/TS16949.

Products

Audio	www.ti.com/audio
Amplifiers	amplifier.ti.com
Data Converters	dataconverter.ti.com
DLP® Products	www.dlp.com
DSP	dsp.ti.com
Clocks and Timers	www.ti.com/clocks
Interface	interface.ti.com
Logic	logic.ti.com
Power Mgmt	power.ti.com
Microcontrollers	microcontroller.ti.com
RFID	www.ti-rfid.com
OMAP Applications Processors	www.ti.com/omap
Wireless Connectivity	www.ti.com/wirelessconnectivity

Applications

Automotive and Transportation	www.ti.com/automotive
Communications and Telecom	www.ti.com/communications
Computers and Peripherals	www.ti.com/computers
Consumer Electronics	www.ti.com/consumer-apps
Energy and Lighting	www.ti.com/energy
Industrial	www.ti.com/industrial
Medical	www.ti.com/medical
Security	www.ti.com/security
Space, Avionics and Defense	www.ti.com/space-avionics-defense
Video and Imaging	www.ti.com/video

TI E2E Community

e2e.ti.com