

# ASMT-M0xx

## Collimator Lens Option for Power LED ASMT-Mxxx and QSMT-MWBx



### Data Sheet



Lead (Pb) Free  
RoHS 6 fully  
compliant



#### Introduction

Power LED Light Source is a high performance energy efficient device which can handle high thermal and high driving current. The Collimator Lens ASMT-M0xx are design to efficiently collimate the light of Power LED ASMT-Mxxx & QSMT-MWBx into a 6°, 15° and 30° beam.

The collimating optics has been effectively design to collimate the light to 6°, 15° and 30° viewing angle. The design and Acrylic material use bring the efficiency >85%.

#### The Lens Material Properties

The lens material is made from optical grade Acrylic and the lens max allowable operating temperature is 75°C. It can be used for all colors.

#### Features

- Available in 6°, 15° & 30° beam
- Energy efficient
- Work with all Power LED ASMT-Mxxx.  
For white QSMT-MWBx is recommended
- Acrylic plastic

#### Applications

- Portable (flash light, bicycle head light)
- Reading light
- Architectural lighting
- Garden lighting
- Decorative lighting

## Collimator Lens Dimension

### ASMT-M006 (6° beam)

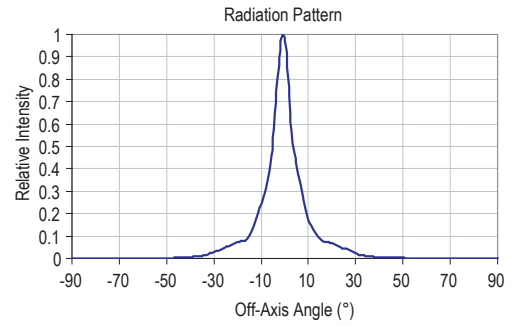
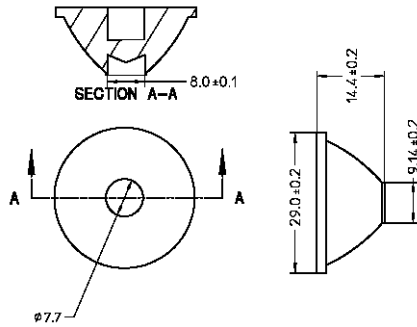

### ASMT-M015 (15° beam)

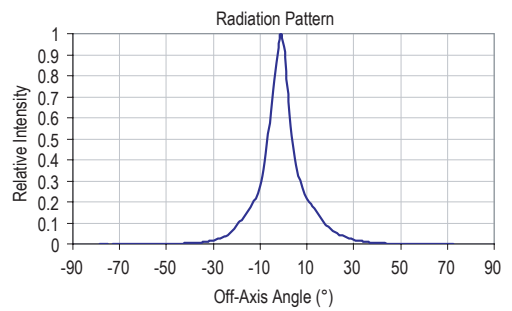
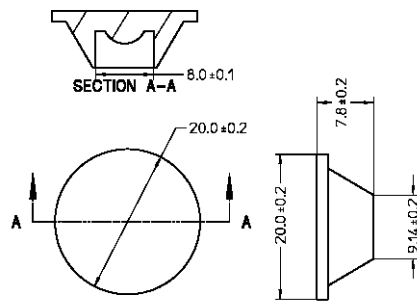

### ASMT-M030 (30° beam)

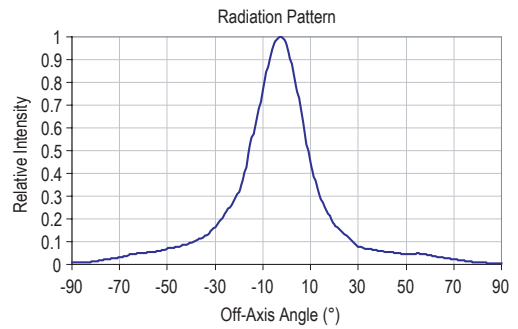
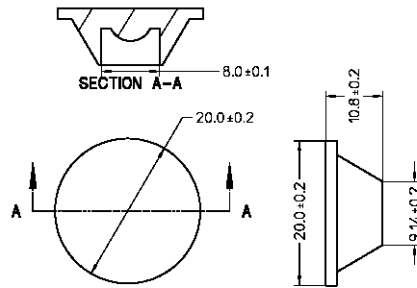

#### Note:

1. All dimensions in millimeters.
2. The collimator rim peripherals surface can be used as a press fitting feature to support the collimator.
3. The light source must be protected from any axial or lateral loads caused by the collimator.
4. The collimator is molded from optical grade Acrylic. Do not subject the collimator to temperature greater than 75 °C as it may deform.

## Device Selection Guide

Part Number	Collimating Angle, Degree (°) Typ
ASMT-M006	6
ASMT-M015	15
ASMT-M030	30

## Application of Collimator Lens

### Lens Attachment

Lens attachment to the unit is through “press-fitting”. To make sure that the lens is properly attached, the lens need to be press-fitted until it reaches a hard stop at the top surface of the unit.

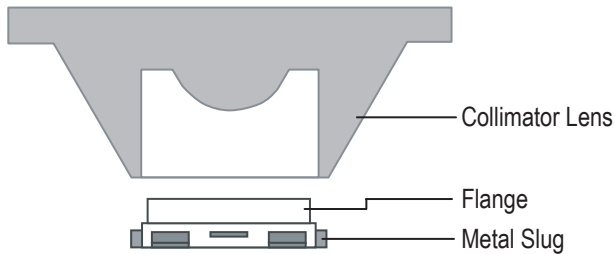

Figure 1. Collimator Lens ASMT-M0xx and ASMT-Mxxx unit

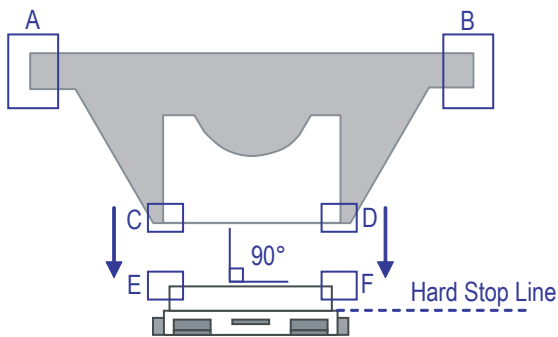

Figure 2. Attachment between collimator lens and unit.

Hold the lens by position A & B and make sure that the lens is perpendicular to the unit top surface as shown in Figure 2.

Surface C and D of the Collimator Lens have to be pressed perpendicularly onto the flange surface of E and F until the hard stop.

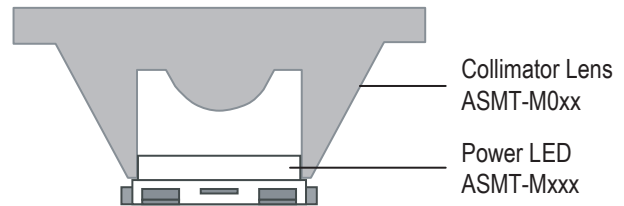

Figure 3. Complete attachment between Collimator Lens and ASMT-Mxxx unit

### Precaution

This lens is designed for press-fitting only. Do not over-press the lens while attaching both lens and unit. No adhesive and/or lubricant is applicable for this application. Avoid using corrosive chemical to clean the lens. Use only Iso Propyl Alcohol (IPA) for this purpose.

# Package Tray Dimensions

For ASMT-M006 (6° beam)

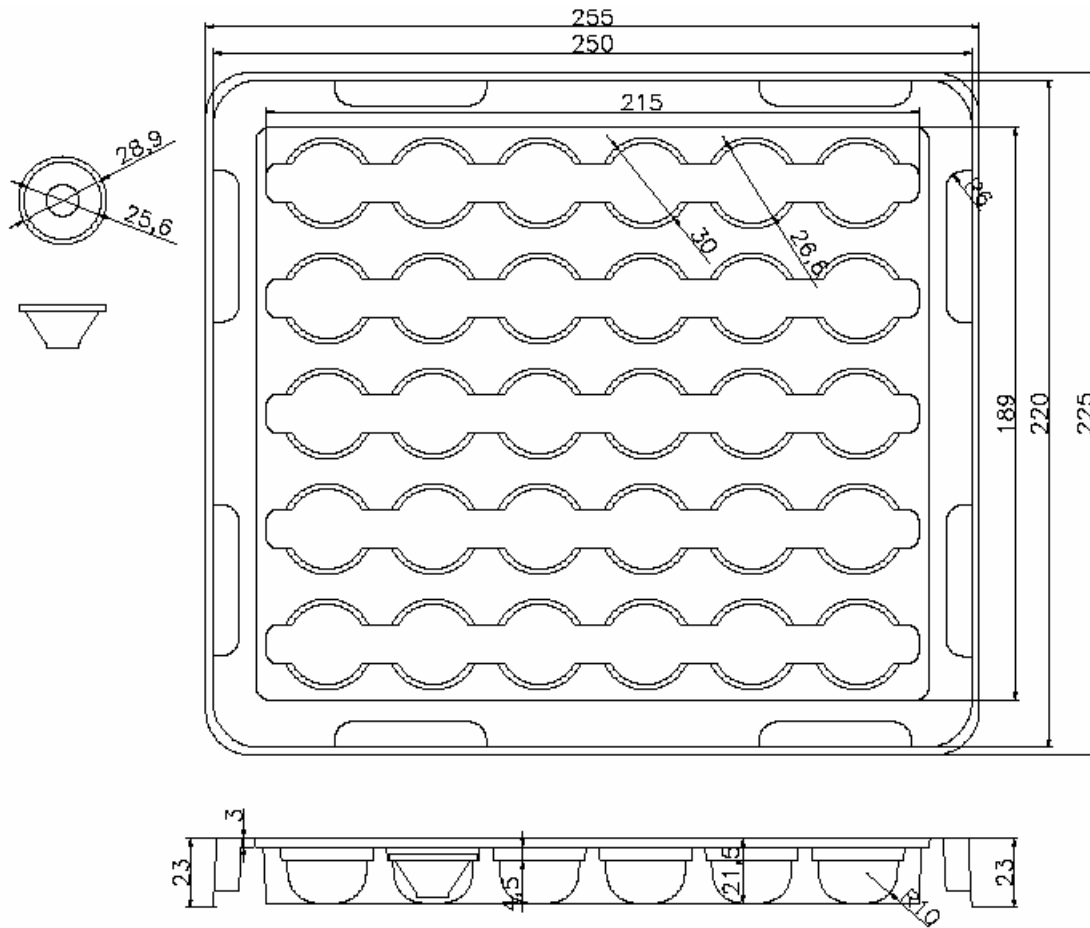

For ASMT-M015 and ASMT-M030 (15° and 30° beam)

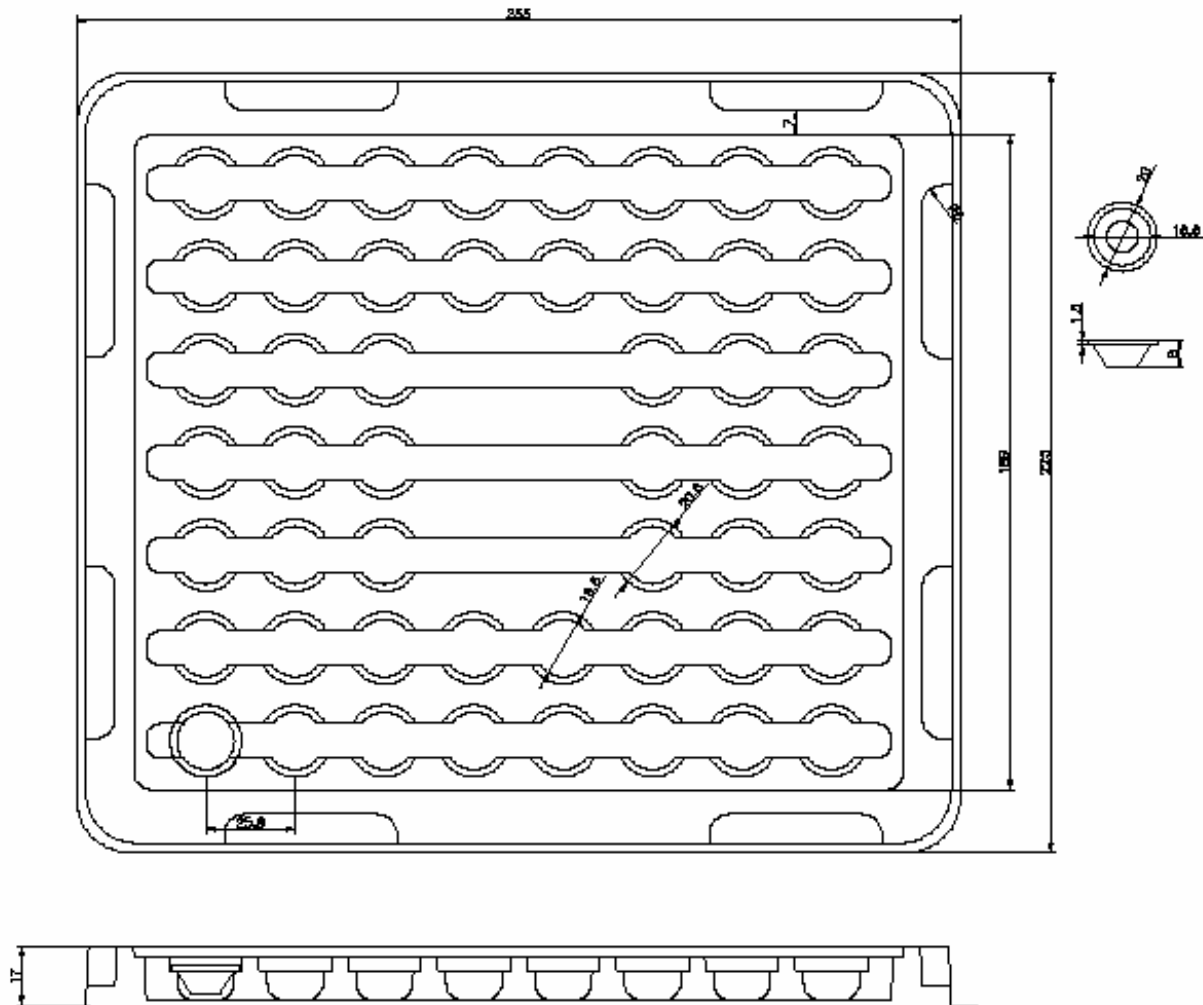

AVAGO'S PRODUCTS AND SOFTWARE ARE NOT SPECIFICALLY DESIGNED, MANUFACTURED OR AUTHORIZED FOR SALE AS PARTS, COMPONENTS OR ASSEMBLIES FOR THE PLANNING, CONSTRUCTION, MAINTENANCE OR DIRECT OPERATION OF A NUCLEAR FACILITY OR FOR USE IN MEDICAL DEVICES OR APPLICATIONS. CUSTOMER IS SOLELY RESPONSIBLE, AND WAIVES ALL RIGHTS TO MAKE CLAIMS AGAINST AVAGO OR ITS SUPPLIERS, FOR ALL LOSS, DAMAGE, EXPENSE OR LIABILITY IN CONNECTION WITH SUCH USE.

For product information and a complete list of distributors, please go to our web site: [www.avagotech.com](http://www.avagotech.com)

Avago, Avago Technologies, and the A logo are trademarks of Avago Technologies, Limited in the United States and other countries. Data subject to change. Copyright © 2007 Avago Technologies Limited. All rights reserved. AV02-0125EN - May 16, 2007

**AVAGO**  
TECHNOLOGIES