

## Rack-mounted Power Transducers 17-RACK

(Operational voltage range 24 V  $\pm$ 10 %, ripple 10 %p-p max.)

### SIGNAL CONVERTER

#### Functions & Features

- Converting a DC input into a standard process signal
- Isolation between input and output

#### Typical Applications

- Isolation between control room and field instrumentation

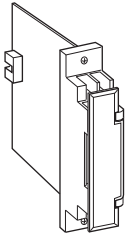

### MODEL: 17VS-[1]6-R

### ORDERING INFORMATION

- Code number: 17VS-[1]6-R
- Specify a code from below for [1].  
(e.g. 17VS-26-R)
- Special input range (For codes Z & 0)

### [1] INPUT

#### Current

- A: 4 - 20 mA DC (Input resistance 250  $\Omega$ )  
 D: 0 - 20 mA DC (Input resistance 50  $\Omega$ )  
 G: 0 - 1 mA DC (Input resistance 1000  $\Omega$ )  
 H: 10 - 50 mA DC (Input resistance 100  $\Omega$ )  
 Z: Specify current (See INPUT SPECIFICATIONS)

#### Voltage

- 1: 0 - 10 mV DC (Input resistance 10 k $\Omega$  min.)  
 2: 0 - 100 mV DC (Input resistance 100 k $\Omega$  min.)  
 3: 0 - 1 V DC (Input resistance 1 M $\Omega$  min.)  
 4: 0 - 10 V DC (Input resistance 1 M $\Omega$  min.)  
 5: 0 - 5 V DC (Input resistance 1 M $\Omega$  min.)  
 6: 1 - 5 V DC (Input resistance 1 M $\Omega$  min.)  
 0: Specify voltage (See INPUT SPECIFICATIONS)

### OUTPUT

#### Voltage

- 6: 1 - 5 V DC (Load resistance 2000  $\Omega$  min.)

### POWER INPUT

#### DC Power

- R: 24 V DC

### GENERAL SPECIFICATIONS

**Construction:** Rack-mounted; terminal access via screw terminals on the front and connector on the rear; terminal cover provided

#### Connection:

**Input:** M3.5 screw terminals (torque 0.8 N·m)

**Output:** Connector

**Power input:** Supplied from connector

**Screw terminal:** Nickel-plated steel

**Isolation:** Input to output to power

**Zero adjustment:** -5 to +5 % (front)

**Span adjustment:** 95 to 105 % (front)

### INPUT SPECIFICATIONS

■ **DC Current:** Input resistor incorporated  
Specify input resistance value for code Z.

( $R \leq 2 W \div [F.S. Current]^2$ )

■ **DC Voltage:** 0 - 300 V DC

**Minimum span:** 3 mV

**Offset:** Max. 1.5 times span

**Input span: Input Resistance**

3 - 10 mV :  $\geq 10 k\Omega$

10 - 100 mV :  $\geq 10 k\Omega$

0.1 - 1 V :  $\geq 100 k\Omega$

$\geq 1 V$  :  $\geq 1 M\Omega$

### OUTPUT SPECIFICATIONS

With the input voltage code 3, 4, 5, 6 and current, the output goes below 0 % when the input is open.

### INSTALLATION

**Current consumption:** Approx. 35 mA

**Operating temperature:** -5 to +55°C (23 to 131°F)

**Operating humidity:** 40 to 85 % RH (non-condensing)

**Mounting:** Standard Rack 17BXE

**Weight:** 150 g (0.33 lb)

### PERFORMANCE in percentage of span

**Accuracy:**  $\pm 0.3$  %

**Temp. coefficient:**  $\pm 0.015$  %/°C ( $\pm 0.008$  %/°F)

**Response time:**  $\leq 0.5$  sec. (0 - 90 %)

**Line voltage effect:**  $\pm 0.1$  % over voltage range

**Insulation resistance:**  $\geq 100 M\Omega$  with 500 V DC

**Dielectric strength:** 1500 V AC @ 1 minute

(input to output or power)

500 V AC @ 1 minute (output to power)

1500 V AC @ 1 minute (input or output or power to ground)

## DIMENSIONS unit: mm (inch)

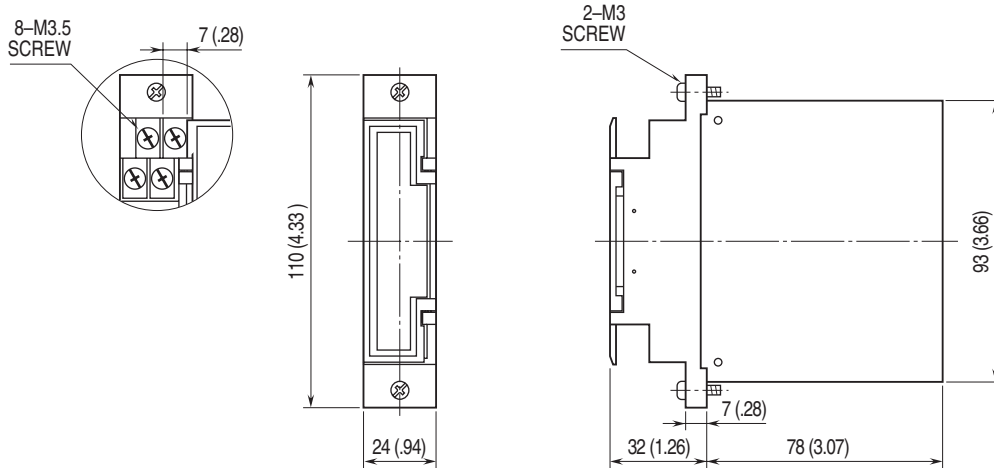

## TERMINAL ASSIGNMENTS

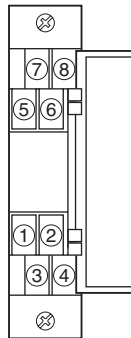

## SCHEMATIC CIRCUITRY & CONNECTION DIAGRAM

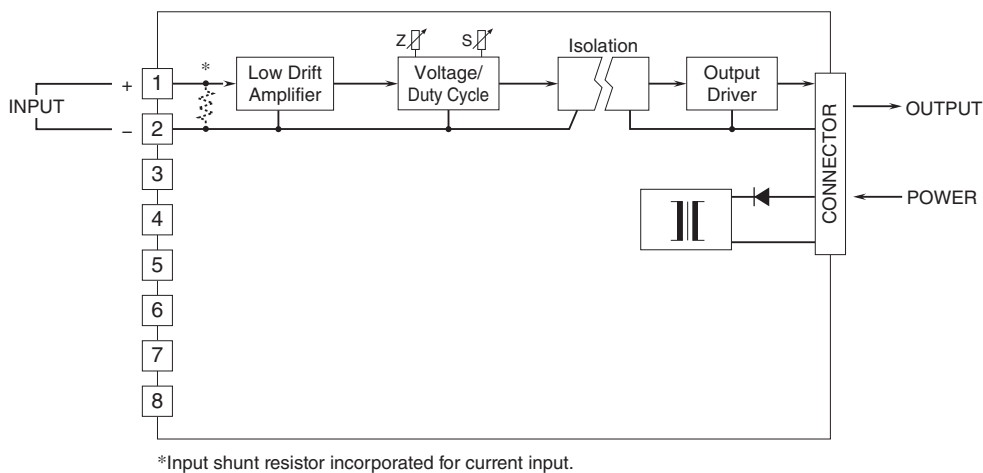



Specifications are subject to change without notice.