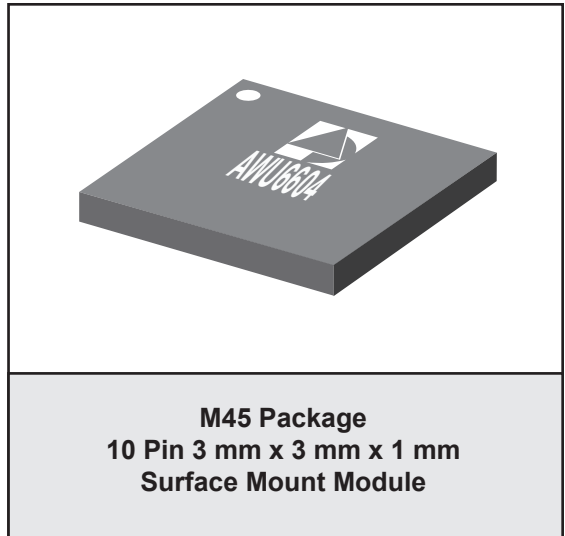


**FEATURES**

- HSPA Compliant
- InGaP HBT Technology
- Low Quiescent Current with only 2 Bias Modes
- Simpler Calibration
- High Efficiency: (R99 waveform)  
 39 % @ P<sub>OUT</sub> = +28.25 dBm  
 21 % @ P<sub>OUT</sub> = +16 dBm
- Low Quiescent Current: 9.0 mA
- Low Leakage Current in Shutdown Mode: <1 μA
- Internal Voltage Regulator
- Integrated “daisy chainable” directional couplers with CPL<sub>IN</sub> and CPL<sub>OUT</sub> Ports
- Optimized for a 50 Ω System
- Low Profile Miniature Surface Mount Package
- RoHS Compliant Package, 260 °C MSL-3

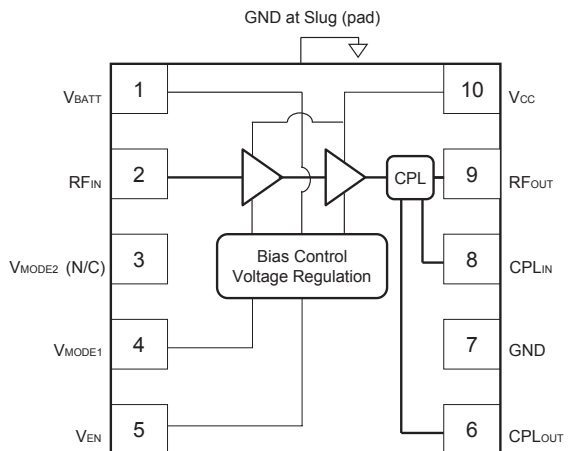


**APPLICATIONS**

- WCDMA/HSPA AWS/UMTS1700-Band Wireless Handsets and Data Devices

**PRODUCT DESCRIPTION**

The AWU6604 HELP3™ PA is a 3rd generation WCDMA product for UMTS handsets. This PA incorporates ANADIGICS’ HELP3™ technology to provide low power consumption without the need for an external voltage regulator. A “daisy chainable” directional coupler is integrated in the module thus eliminating the need of external couplers. The device is manufactured on an advanced InGaP HBT MMIC technology offering state-of-the-art reliability, temperature stability, and ruggedness. There are two selectable bias modes that optimize efficiency for different output power levels, and a shutdown mode with low leakage current, which increases handset talk and standby time. The self-contained 3 mm x 3 mm x 1 mm surface mount package incorporates matching networks optimized for output power, efficiency, and linearity in a 50 Ω system.



**Figure 1: Block Diagram**

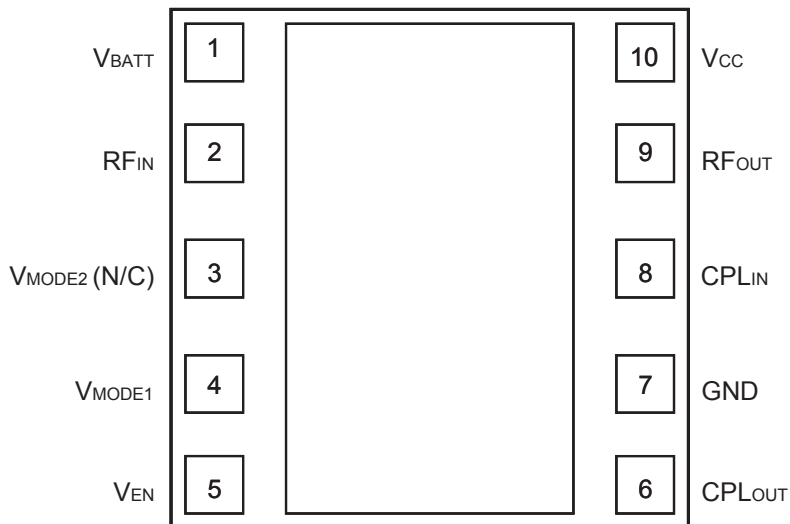


Figure 2: Pinout (X-ray Top View)

Table 1: Pin Description

PIN	NAME	DESCRIPTION
1	V <sub>BATT</sub>	Battery Voltage
2	RF <sub>IN</sub>	RF Input
3	V <sub>MODE2</sub> (N/C)	No Connection
4	V <sub>MODE1</sub>	Mode Control Voltage 1
5	V <sub>EN</sub>	PA Enable Voltage
6	CPL <sub>OUT</sub>	Coupler Output
7	GND	Ground
8	CPL <sub>IN</sub>	Coupler Input
9	RF <sub>OUT</sub>	RF Output
10	V <sub>CC</sub>	Supply Voltage

**ELECTRICAL CHARACTERISTICS**

**Table 2: Absolute Minimum and Maximum Ratings**

PARAMETER	MIN	MAX	UNIT
Supply Voltage (V <sub>CC</sub> )	0	+5	V
Battery Voltage (V <sub>BATT</sub> )	0	+6	V
Control Voltages (V <sub>MODE1</sub> , V <sub>ENABLE</sub> )	0	+3.5	V
RF Input Power (P <sub>IN</sub> )	-	+10	dBm
Storage Temperature (T <sub>STG</sub> )	-40	+150	°C

Stresses in excess of the absolute ratings may cause permanent damage. Functional operation is not implied under these conditions. Exposure to absolute ratings for extended periods of time may adversely affect reliability.

**Table 3: Operating Ranges**

PARAMETER	MIN	TYP	MAX	UNIT	COMMENTS
Operating Frequency (f)	1710	-	1785	MHz	
Supply Voltage (V <sub>CC</sub> )	+3.2	+3.4	+4.2	V	P <sub>OUT</sub> ≤ +28.25 dBm
Enable Voltage (V <sub>ENABLE</sub> )	+2.15 0	+2.4 0	+3.1 +0.5	V	PA "on" PA "shut down"
Mode Control Voltage (V <sub>MODE1</sub> )	+2.15 0	+2.4 0	+3.1 +0.5	V	Low Bias Mode High Bias Mode
RF Output Power (P <sub>OUT</sub> ) R99 WCDMA, HPM HSPA (MPR=0), HPM R99 WCDMA, LPM HSPA (MPR=0), LPM	27.75 <sup>(1)</sup> 26.75 <sup>(1)</sup> 15.5 <sup>(1)</sup> 14.5 <sup>(1)</sup>	28.25 27.25 16 15	28.25 27.25 16 15	dBm	3GPP TS 34.121-1, Rel 8 Table C.11.1.3
Case Temperature (T <sub>c</sub> )	-30	-	+90	°C	

The device may be operated safely over these conditions; however, parametric performance is guaranteed only over the conditions defined in the electrical specifications.

Notes:

(1) For operation at V<sub>CC</sub> = +3.2 V, P<sub>OUT</sub> is derated by 0.5 dB.

**Table 4: Electrical Specifications**  
 (T<sub>c</sub> = +25 °C, V<sub>CC</sub> = +3.4 V, V<sub>BATT</sub> = +3.4 V, V<sub>ENABLE</sub> = +2.4 V, 50 Ω system, R99 waveform)

PARAMETER	MIN	TYP	MAX	UNIT	COMMENTS	
					P <sub>OUT</sub>	V <sub>MODE1</sub>
Gain	24.5 11.5	27 14	29.5 16.5	dB	+28.25 dBm +16 dBm	0 V 2.4 V
ACLR1 at 5 MHz offset <sup>(1)</sup>	- -	-42 -44	-38 -38	dBc	+28.25 dBm +16 dBm	0 V 2.4 V
ACLR2 at 10 MHz offset	- -	-55 -54	-48 -48	dBc	+28.25 dBm +16 dBm	0 V 2.4 V
Power-Added Efficiency <sup>(1)</sup>	35 18	38.5 21	- -	%	+28.25 dBm +16 dBm	0 V 2.4 V
Quiescent Current (I <sub>q</sub> ) Low Bias Mode	-	9.0	14	mA	V <sub>MODE1</sub> = +2.4 V	
Mode Control Current	-	0.35	0.6	mA	through V <sub>MODE</sub> pin, V <sub>MODE1</sub> = +2.4 V	
Enable Current	-	0.35	0.6	mA	through V <sub>ENABLE</sub> pin	
BATT Current	-	2.5	5	mA	through V <sub>BATT</sub> pin, V <sub>MODE1</sub> = +2.4 V	
Leakage Current	-	<1	5	μA	V <sub>BATT</sub> = +4.2 V, V <sub>CC</sub> = +4.2 V, V <sub>ENABLE</sub> = 0 V, V <sub>MODE1</sub> = 0 V	
Noise in Receive Band	- - -	-136 -145 -137	-134 -141 -135	dBm/Hz	1845 - 1880 MHz 2110 - 2155 MHz 1574.4 - 1576.4 MHz	
Harmonics 2fo 3fo, 4fo	- -	-42 -46	-35 -35	dBc	P <sub>OUT</sub> ≤ +28.25 dBm	
Input Impedance	-	-	2:1	VSWR		
Coupling Factor	-	20	-	dB		
Directivity	-	19	-	dB		
Spurious Output Level (all spurious outputs)	-	-	-70	dBc	P <sub>OUT</sub> ≤ +28.25 dBm In-band load VSWR < 5:1 Out-of-band load VSWR < 10:1 Applies over all operating conditions	
Load mismatch stress with no permanent degradation or failure	8:1	-	-	VSWR	Applies over full operating range	

Notes:

(1) ACLR and Efficiency measured at 1747.5 MHz.

## APPLICATION INFORMATION

To ensure proper performance, refer to all related Application Notes on the ANADIGICS web site: <http://www.anadigics.com>

### Shutdown Mode

The power amplifier may be placed in a shutdown mode by applying logic low levels (see Operating Ranges table) to the  $V_{ENABLE}$  and  $V_{MODE1}$  voltages.

### Bias Modes

The power amplifier may be placed in either a Low Bias mode or a High Bias mode by applying the appropriate

logic level (see Operating Ranges table) to  $V_{MODE1}$ . The Bias Control table lists the recommended modes of operation for various applications.  $V_{MODE2}$  is not necessary for this PA.

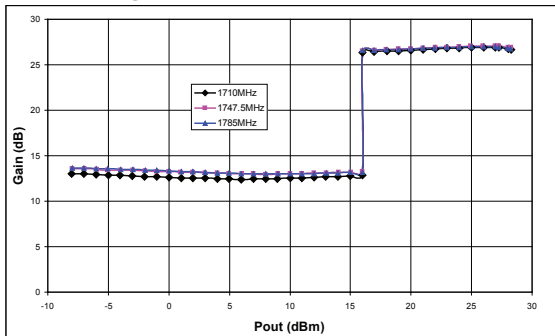
Two operating modes are available to optimize current consumption. High Bias/High Power operating mode is for  $P_{OUT}$  levels  $\geq 15$  dBm. At around 16 dBm output power, the PA should be "Mode Switched" to Medium/Low power mode for lowest quiescent current consumption.

Table 5: Bias Control (UMTS)

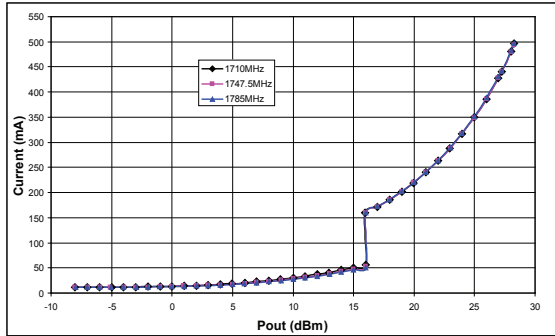
APPLICATION	$P_{OUT}$ LEVELS	BIAS MODE	$V_{ENABLE}$	$V_{MODE1}$	$V_{CC}$	$V_{BATT}$
UMTS - med/low power (Low Bias Mode)	$\leq +16$ dBm	Low	+2.4 V	+2.4 V	3.2 - 4.2 V	$\geq 3.2$ V
UMTS - high power (High Bias Mode)	$> +15$ dBm	High	+2.4 V	0 V	3.2 - 4.2 V	$\geq 3.2$ V
Optional lower $V_{CC}$ in low power mode	$\leq +6$ dBm	Low	+2.4 V	+2.4 V	1.5 V	$\geq 3.2$ V
Shutdown	-	Shutdown	0 V	0 V	3.2 - 4.2 V	$\geq 3.2$ V

**CHARACTERIZATION DATA**  
(WCDMA Rel 99,  $V_{CC} = 3.4\text{ V}$ ,  $V_{EN} = 2.4\text{ V}$ ,  $T = 25\text{ }^{\circ}\text{C}$ )

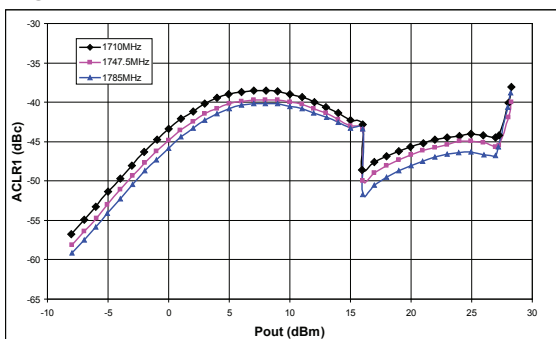
**Figure 3: Gain vs Output Power**



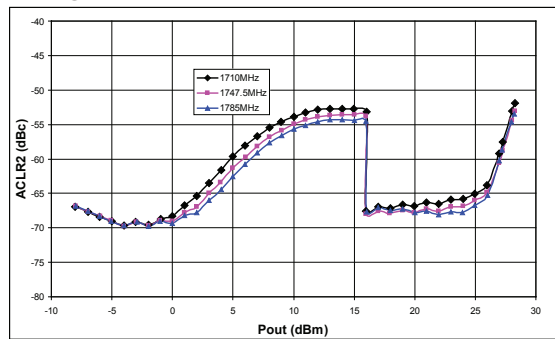
**Figure 4: Current vs Output Power**



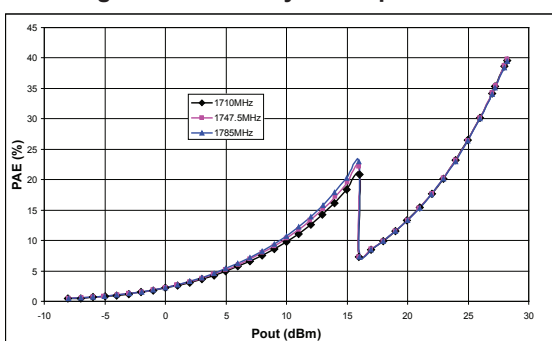
**Figure 5: ACLR1 (5 MHz offset) vs Output Power**



**Figure 6: ACLR2 (10 MHz offset) vs Output**

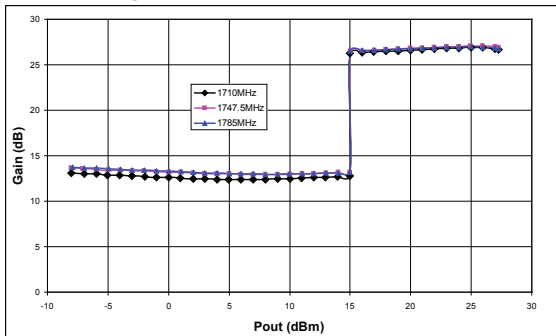


**Figure 7: Efficiency vs Output Power**

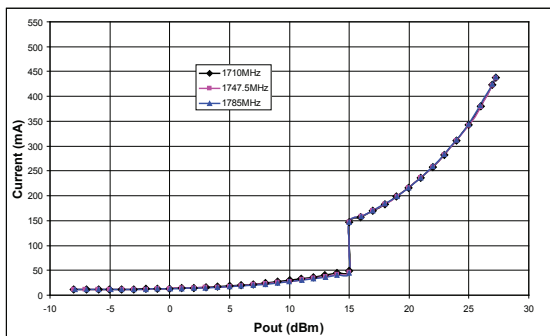


**CHARACTERIZATION DATA**  
 (HSPA, Rel 8,  $V_{CC} = 3.4\text{ V}$ ,  $V_{EN} = 2.4\text{ V}$ ,  $T = 25\text{ }^{\circ}\text{C}$ )

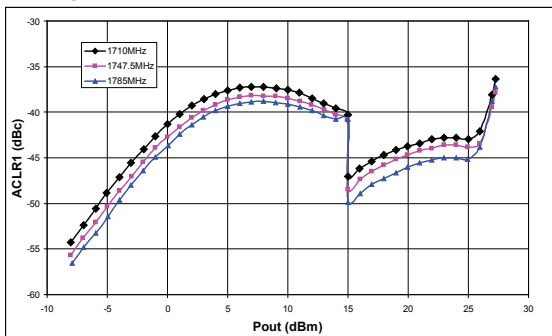
**Figure 8: Gain vs Output Power**



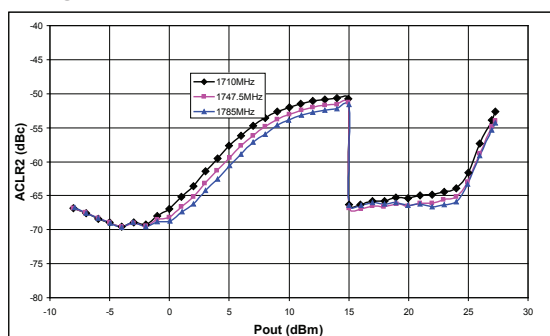
**Figure 9: Current vs Output Power**



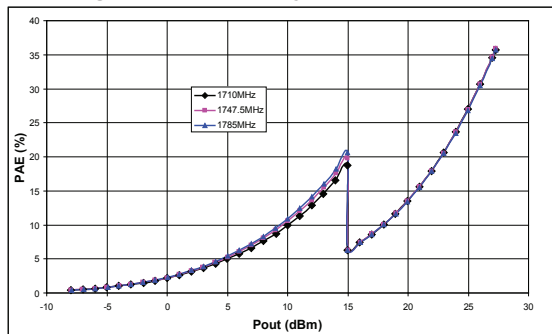
**Figure 10: ACLR1 (5 MHz offset) vs Output**



**Figure 11: ACLR2 (10 MHz offset) vs Output**



**Figure 12: Efficiency vs Output Power**



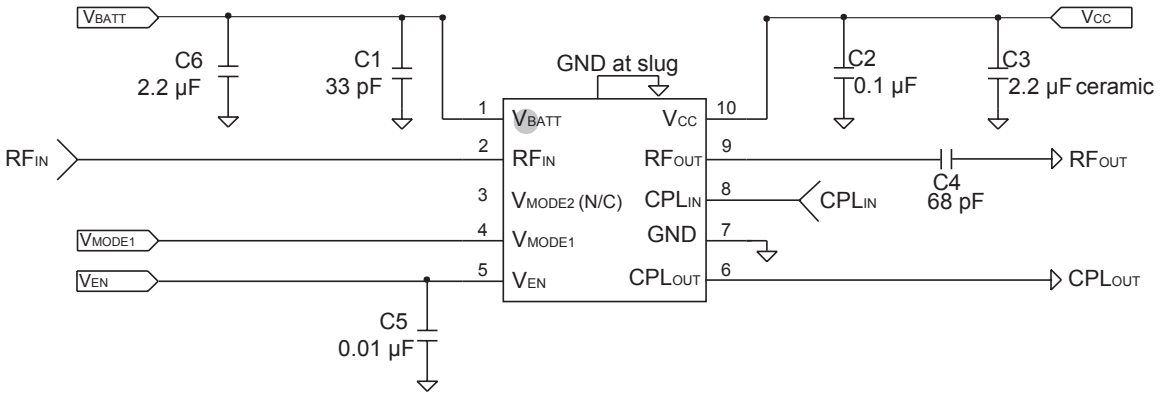


Figure 13: Evaluation Circuit Schematic

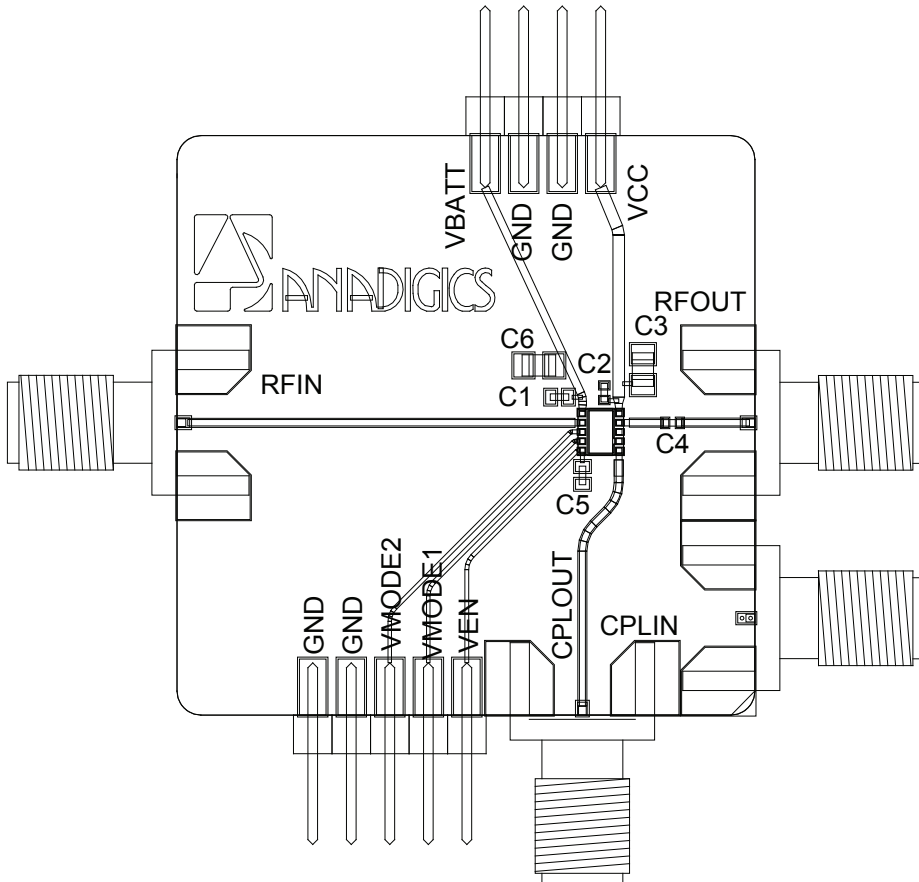


Figure 14: Evaluation Board Layout

**HELP3**

The AWU6604 power amplifier module is based on ANADIGICS proprietary HELP3™ technology. The PA is designed to operate up to 17 dBm in the low power mode, thus eliminating the need for three gain state, while still maintaining low quiescent current and high efficiency in low and medium power levels. The PA can still be operated as 3 gain state device if the customer chooses to. The directional “daisy chainable” coupler is integrated within the PA module, therefore there is no need for external couplers.

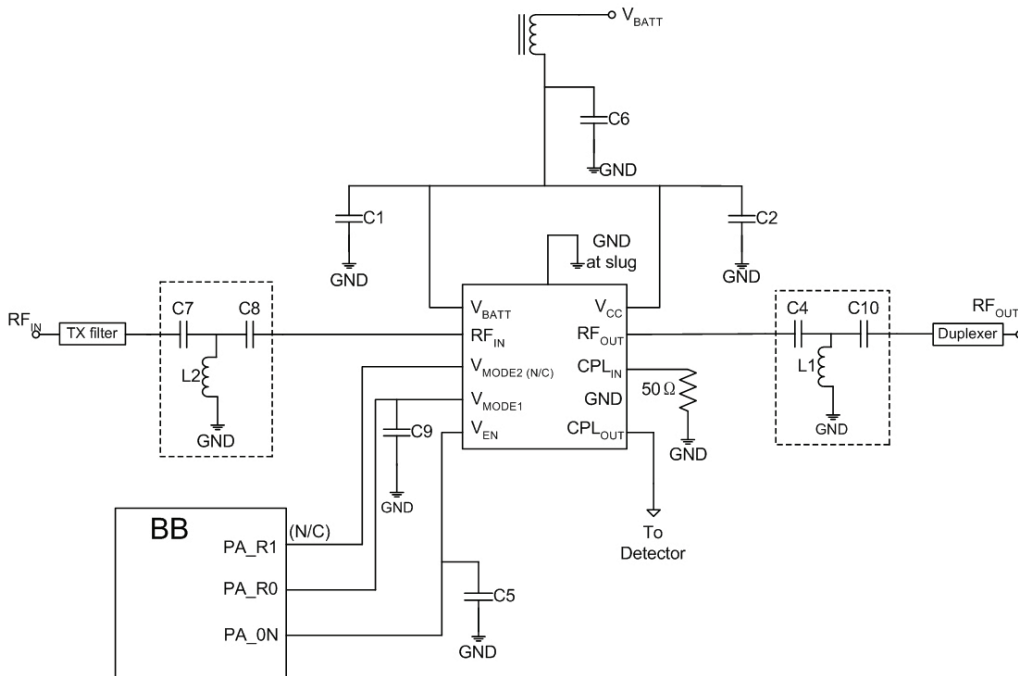
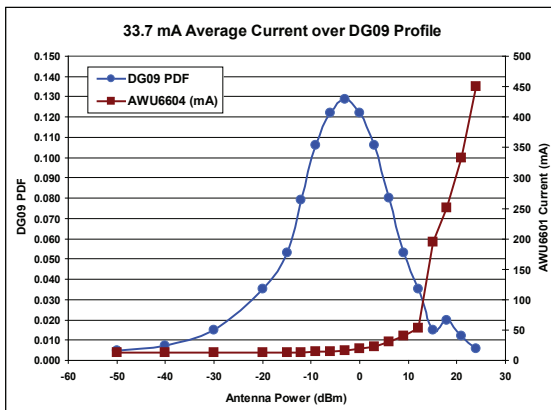
The AWU6604 has an integrated voltage regulator, which eliminates the need for an external constant voltage source. The PA is turn on/off is controlled by V<sub>EN</sub> pin. A single V<sub>MODE</sub> control logic (V<sub>MODE1</sub>) is needed to operate this device.

The DG09 power distribution (figure 15) highlights the need to improve the current consumption in low and medium power level. The AWU6604 is designed to operate up to 17 dBm in the low power mode with very low quiescent current. Current consumption for AWU6604 is also plotted in the figure 5.

AWU6604 requires only two calibration sweeps for system calibration, thus saving calibration time.

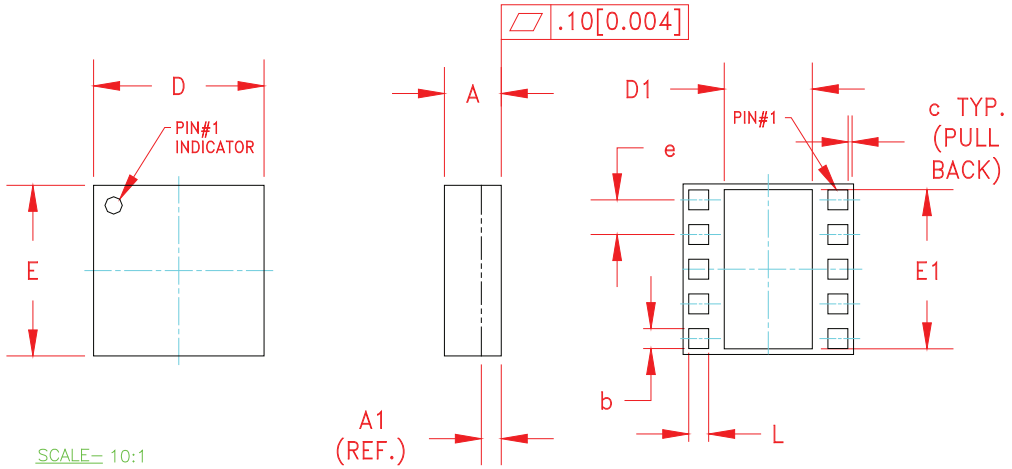
Figure 16 shows one application example on mobile board. C1 and C2 are RF bypass caps and should be placed nearby pin 1 and pin 10. Bypass caps C9 and C5 may not be needed. Also a “T” matching topology is recommended at PA RF<sub>IN</sub> and RF<sub>OUT</sub> ports to provide matching between input TX Filter and Duplexer / Isolator.

**Figure 15: PDF and Current**



**Figure 16: Typical Application Circuit**

PACKAGE OUTLINE



SYMBOL	MILLIMETERS			INCHES			NOTE
	MIN.	NOM.	MAX.	MIN.	NOM.	MAX.	
A	0.91	1.03	1.13	0.035	0.041	0.044	-
A1	PLEASE REFER TO LAMINATE CONTROL DRAWING						-
b	0.32	0.35	0.40	0.013	0.014	0.016	3
c	-	0.10	-	-	0.004	-	-
D	2.88	3.00	3.12	0.113	0.118	0.123	-
D1	1.45	1.50	1.57	0.057	0.059	0.062	3
E	2.88	3.00	3.12	0.113	0.118	0.123	-
E1	2.70	2.75	2.85	0.106	0.108	0.112	3
e	0.60			0.024			3
L	0.32	0.35	0.40	0.013	0.014	0.016	3

NOTES:

1. CONTROLLING DIMENSIONS: MILLIMETERS
2. UNLESS SPECIFIED TOLERANCE=±0.076[0.003].
3. PADS (INCLUDING CENTER) SHOWN UNIFORM SIZE FOR REFERENCE ONLY. ACTUAL PAD SIZE AND LOCATION WILL VARY WITHIN MIN. AND MAX. DIMENSIONS ACCORDING TO SPECIFIC LAMINATE DESIGN.
4. UNLESS SPECIFIED DIMENSIONS ARE SYMMETRICAL ABOUT CENTER LINES SHOWN.
5. LAMINATE CONTROL DRAWING SPECIFIED BY PART NUMBER.

Figure 17: M45 Package Outline - 10 Pin 3 mm x 3 mm x 1 mm Surface Mount Module

TOP BRAND

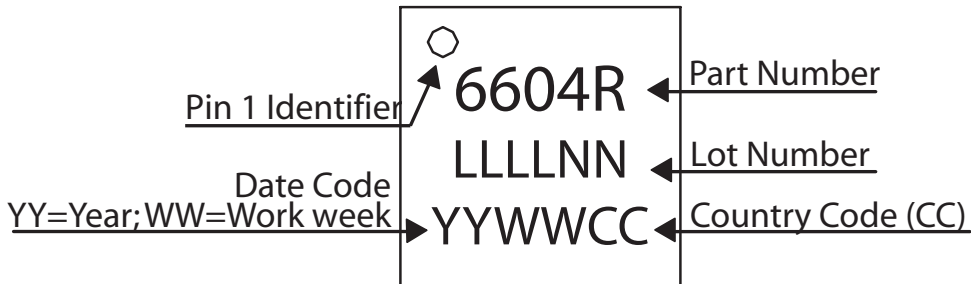
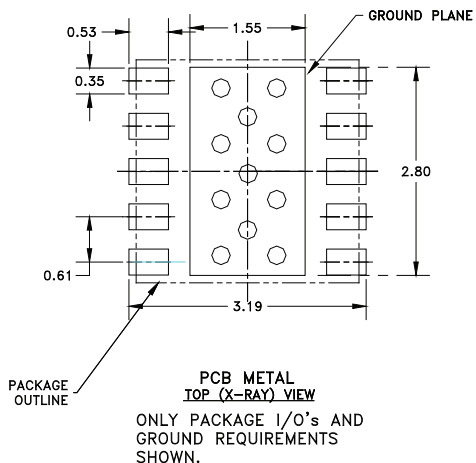


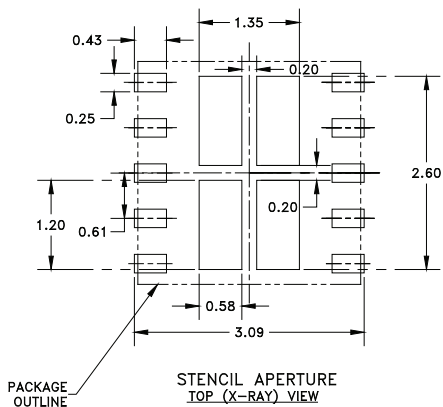
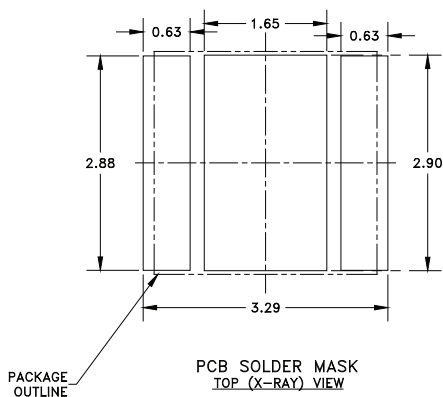
Figure 18: Branding Specification - M45 Package

PCB AND STENCIL DESIGN GUIDELINE



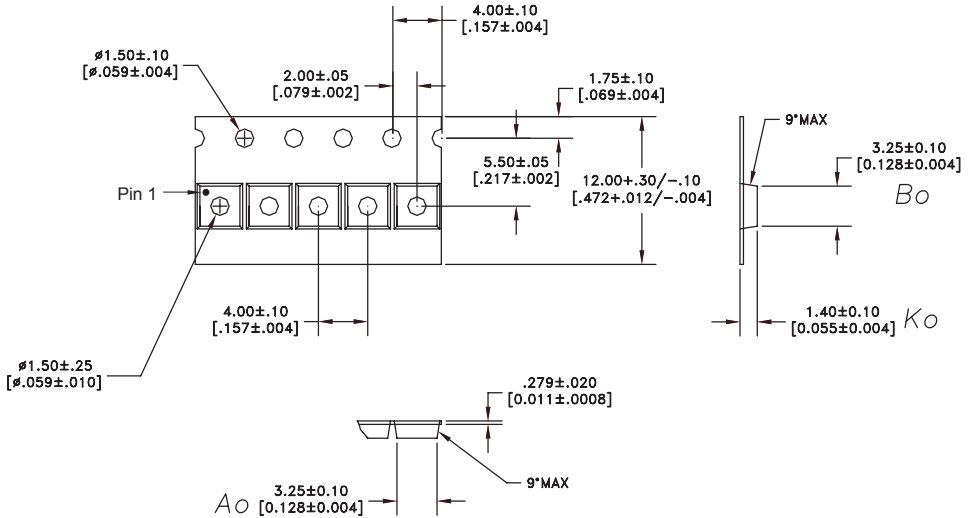
**NOTES:**

- (1) OUTLINE DRAWING REFERENCE: P8002478\_E
- (2) UNLESS SPECIFIED DIMENSIONS ARE SYMMETRICAL ABOUT CENTER LINES SHOWN.
- (3) DIMENSIONS IN MILLIMETERS.
- (4) VIAS SHOWN IN PCB METAL VIEW ARE FOR REFERENCE ONLY. NUMBER & SIZE OF THERMAL VIAS REQUIRED DEPENDENT ON HEAT DISSIPATION REQUIREMENT AND THE PCB PROCESS CAPABILITY.
- (5) RECOMMENDED STENCIL THICKNESS: APPROX. 0.150mm (6 Mils)



**Figure 19: Recommended PCB Layout Information**

COMPONENT PACKAGING



NOTES:

- 1. MATERIAL: 3000 (CARBON FILLED POLYCARBONATE)  
100% RECYCLABLE.

DIMENSIONS ARE IN MILLIMETERS [INCHES]

*DIMENSIONING AND TOLERANCING PER ASME Y14.5M-1994*

Figure 20: Tape & Reel Packaging

Table 6: Tape & Reel Dimensions

PACKAGE TYPE	TAPE WIDTH	POCKET PITCH	REEL CAPACITY	MAX REEL DIA
3 mm x 3 mm x 1 mm	12 mm	4 mm	2500	7"

**ORDERING INFORMATION**

ORDER NUMBER	TEMPERATURE RANGE	PACKAGE DESCRIPTION	COMPONENT PACKAGING
AWU6604RM45Q7	-30 °C to +90 °C	RoHS Compliant 10 Pin 3 mm x 3 mm x 1 mm Surface Mount Module	Tape and Reel, 2500 pieces per Reel
AWU6604RM45P9	-30 °C to +90 °C	RoHS Compliant 10 Pin 3 mm x 3 mm x 1 mm Surface Mount Module	Partial Tape and Reel



**ANADIGICS, Inc.**  
 141 Mount Bethel Road  
 Warren, New Jersey 07059, U.S.A.  
 Tel: +1 (908) 668-5000  
 Fax: +1 (908) 668-5132

URL: <http://www.anadigics.com>

**IMPORTANT NOTICE**

ANADIGICS, Inc. reserves the right to make changes to its products or to discontinue any product at any time without notice. The product specifications contained in Advanced Product Information sheets and Preliminary Data Sheets are subject to change prior to a product's formal introduction. Information in Data Sheets have been carefully checked and are assumed to be reliable; however, ANADIGICS assumes no responsibilities for inaccuracies. ANADIGICS strongly urges customers to verify that the information they are using is current before placing orders.

**WARNING**

ANADIGICS products are not intended for use in life support appliances, devices or systems. Use of an ANADIGICS product in any such application without written consent is prohibited.