

**Surface Mount Fast Recovery Rectifiers**
**Reverse Voltage - 50 to 1000 V**
**Forward Current - 3 A**
**FEATURES**

- For surface mounted applications
- Low profile package
- Glass Passivated Chip Junction
- Easy to pick and place
- Fast reverse recovery time
- Lead free in comply with EU RoHS 2011/65/EU directives

**MECHANICAL DATA**

- Case: SMBF
- Terminals: Solderable per MIL-STD-750, Method 2026
- Approx. Weight: 57mg / 0.002oz

**PINNING**

| PIN | DESCRIPTION |
|-----|-------------|
| 1   | Cathode     |
| 2   | Anode       |

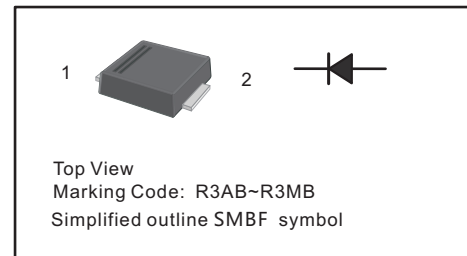
**Absolute Maximum Ratings and Characteristics**

Ratings at 25 °C ambient temperature unless otherwise specified. Single phase, half wave, 60 Hz, resistive or inductive load. For capacitive load, derate current by 20%.

| Parameter  | Symbols                            | RS3ABF     | RS3BBF | RS3DBF | RS3GBF | RS3JBF | RS3KBF | RS3MBF | Units              |
|--|------------------------------------|------------|--------|--------|--------|--------|--------|--------|--------------------|
| Maximum Repetitive Peak Reverse Voltage  | $V_{RRM}$                          | 50         | 100    | 200    | 400    | 600    | 800    | 1000   | V                  |
| Maximum RMS voltage  | $V_{RMS}$                          | 35         | 70     | 140    | 280    | 420    | 560    | 700    | V                  |
| Maximum DC Blocking Voltage  | $V_{DC}$                           | 50         | 100    | 200    | 400    | 600    | 800    | 1000   | V                  |
| Maximum Average Forward Rectified Current at $T_c = 125\text{ }^\circ\text{C}$   | $I_{F(AV)}$                        | 3          |        |        |        |        |        |        | A                  |
| Peak Forward Surge Current 8.3 ms Single Half Sine Wave Superimposed on Rated Load   | $I_{FSM}$                          | 100        |        |        |        |        |        |        | A                  |
| Maximum Forward Voltage at 3 A   | $V_F$                              | 1.3        |        |        |        |        |        |        | V                  |
| Maximum DC Reverse Current at Rated DC Blocking Voltage<br>$T_a = 25\text{ }^\circ\text{C}$<br>$T_a = 125\text{ }^\circ\text{C}$ | $I_R$                              | 5<br>100   |        |        |        |        |        |        | $\mu\text{A}$      |
| Typical Junction Capacitance at $V_R = 4\text{V}$ , $f = 1\text{MHz}$  | $C_j$                              | 40         |        |        |        |        |        |        | pF                 |
| Maximum Reverse Recovery Time <sup>(1)</sup>   | $t_{rr}$                           | 150        |        |        |        | 250    | 500    |        | ns                 |
| Typical Thermal Resistance <sup>(2)</sup>  | $R_{\theta JA}$<br>$R_{\theta JC}$ | 45<br>15   |        |        |        |        |        |        | $^\circ\text{C/W}$ |
| Operating and Storage Temperature Range  | $T_j, T_{stg}$                     | -55 ~ +150 |        |        |        |        |        |        | $^\circ\text{C}$   |

( 1 ) Measured with  $I_F = 0.5\text{ A}$ ,  $I_R = 1\text{ A}$ ,  $I_{rr} = 0.25\text{ A}$ .

( 2 ) P.C.B. mounted with 2.0" X 2.0" (5 X 5 cm) copper pad areas.

Fig.1 Maximum Average Forward Current Rating

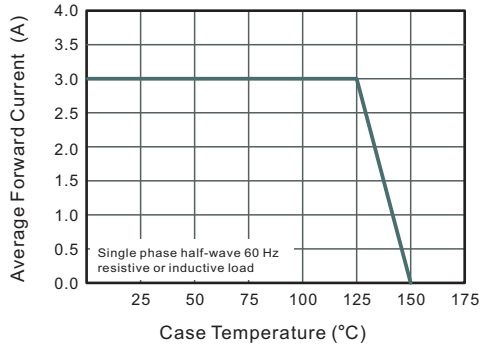

Fig.2 Typical Reverse Characteristics

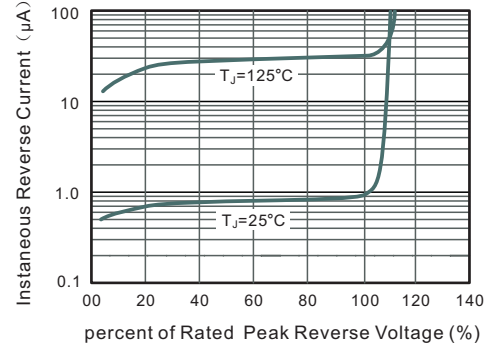

Fig.3 Typical Instantaneous Forward Characteristics

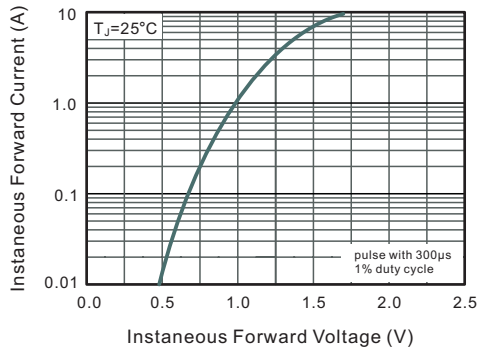

Fig.4 Typical Junction Capacitance

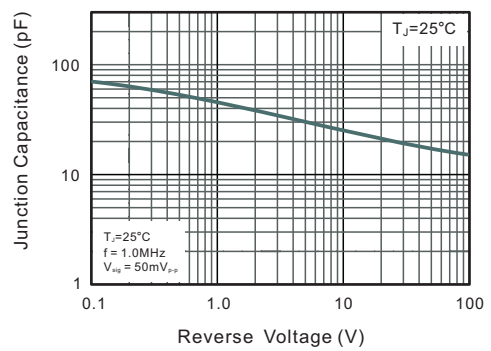
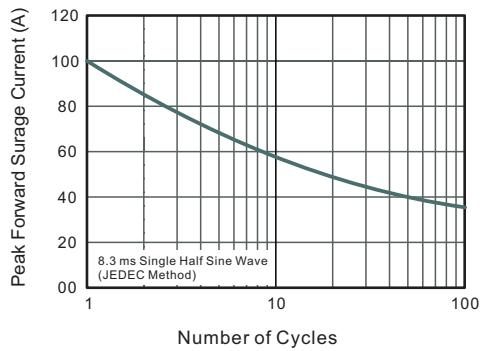

Fig.5 Maximum Non-Repetitive Peak Forward Surge Current



**PACKAGE OUTLINE**

Plastic surface mounted package; 2 leads

SMBF

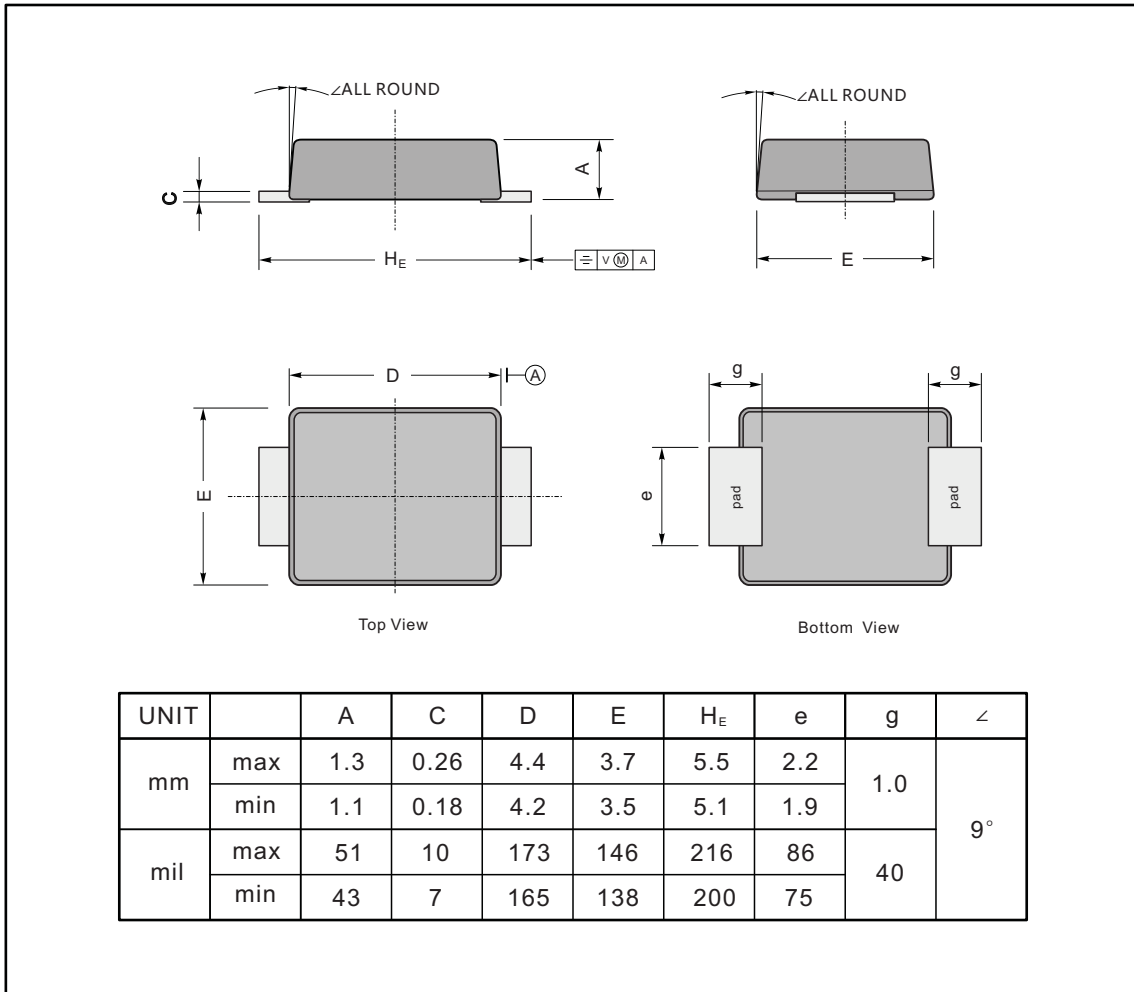

**The recommended mounting pad size**

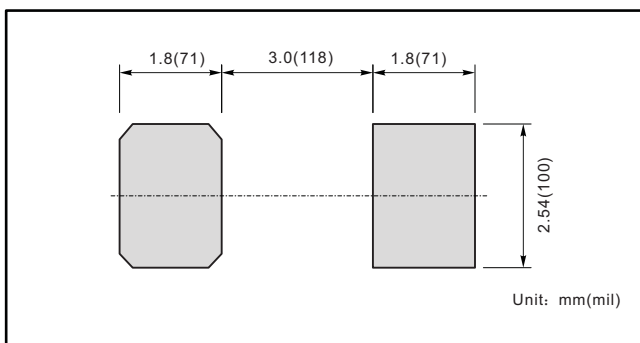

**Marking**

| Type number | Marking code |
|-------------|--------------|
| RS3ABF      | R3AB         |
| RS3BBF      | R3BB         |
| RS3DBF      | R3DB         |
| RS3GBF      | R3GB         |
| RS3JBF      | R3JB         |
| RS3KBF      | R3KB         |
| RS3MBF      | R3MB         |