

# CPTC Thermistor: Twin SMD Type PPL Series

## Overload Protection for Telecom Application



### ■ Features

1. RoHS compliant
2. Two resistance-matched PTCs in a plastic housing
3. Wide resistance range in telecom area from 10 to 50Ω
4. Agency recognition: UL/cUL/TUV
5. Compliant with ITU-T standards
6. Operating temperature range : 0 ~ +60°C (V=Vmax)  
-25 ~ +125°C (V=0)



### ■ Recommended Applications

1. Cable Modem, ADSL Modem with VOIP
2. Customer Premise Equipment (CPE)
3. Central Office (CO)
4. Access Equipment (AE)
5. Main Distribution Frame (MDF)
6. Public Switched Telephone Network (PSTN)
7. Exchanger

### ■ Part Number Code

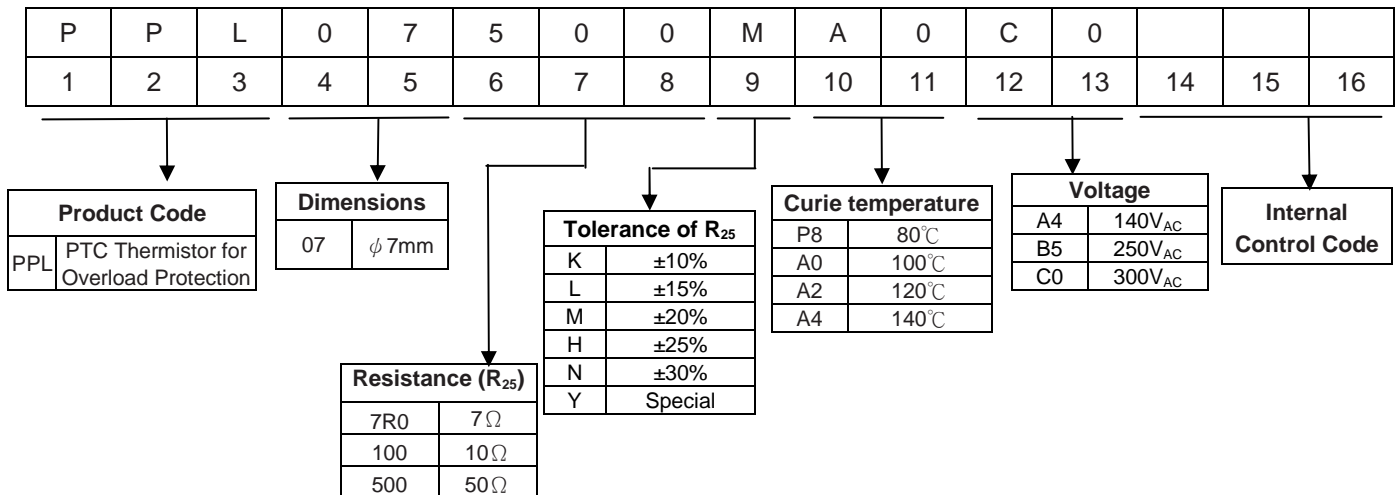

# CPTC Thermistor: Twin SMD Type PPL Series Overload Protection for Telecom Application



## Structure and Dimensions

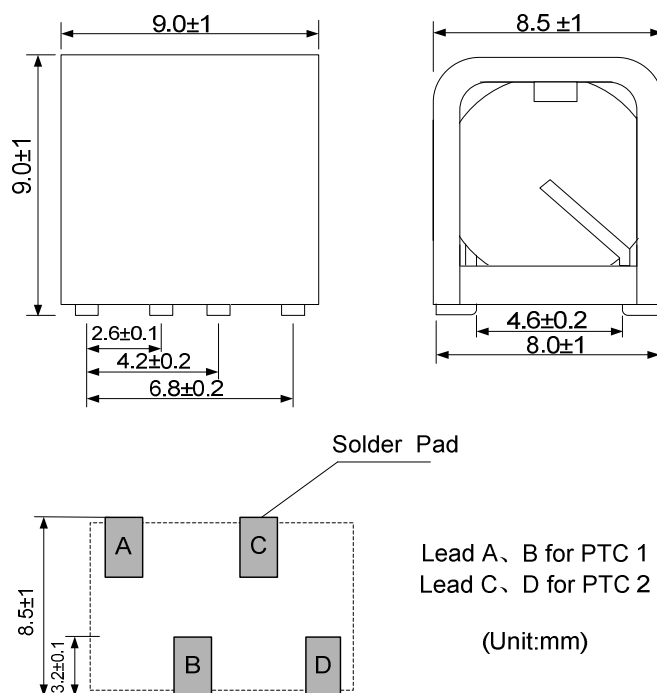

## Characteristics

Part No.	Nominal Zero-power Resistance	Resistance Matching In Housing	Non-operating Current at 25°C	Non-operating Current at 40°C	Trip Current at 25°C	Responding Time (s)			Max Voltage	Max. Current	Safety Approvals	
	R <sub>25</sub> (Ω)	R <sub>1</sub> -R <sub>2</sub>   (Ω)	I <sub>N</sub> (mA) @25°C	I <sub>N</sub> (mA) @40°C	I <sub>t</sub> (mA) @25°C	3A→0.5A	1A→0.5A	0.5A→0.15A	(V <sub>AC</sub> )	I <sub>max</sub> (A)	UL/cUL	TUV
PPL07100□A0B5-Y	10	±0.5	130	120	390	0.8	8.0	35	250	2.5	√	√
PPL07180□A0B5-Y	18		110	100	330	0.4	2.5	10	250	3	√	√
PPL07250□A0B5-Y	25		90	80	225	0.35	2.0	10	250	3	√	√
PPL07390□A0B5-Y	39		70	65	180	0.3	1.0	4.0	250	3	√	√
PPL07500□A0C0-Y	50		60	55	165	0.15	0.8	3.5	300	3	√	√

Note1: □=Tolerance of R<sub>25</sub>

Note2: UL/cUL File No. E138827

TUV File No. R 50171789

# CPTC Thermistor: Twin SMD Type PPL Series Overload Protection for Telecom Application



## R-T Characteristic Curves (Typical)

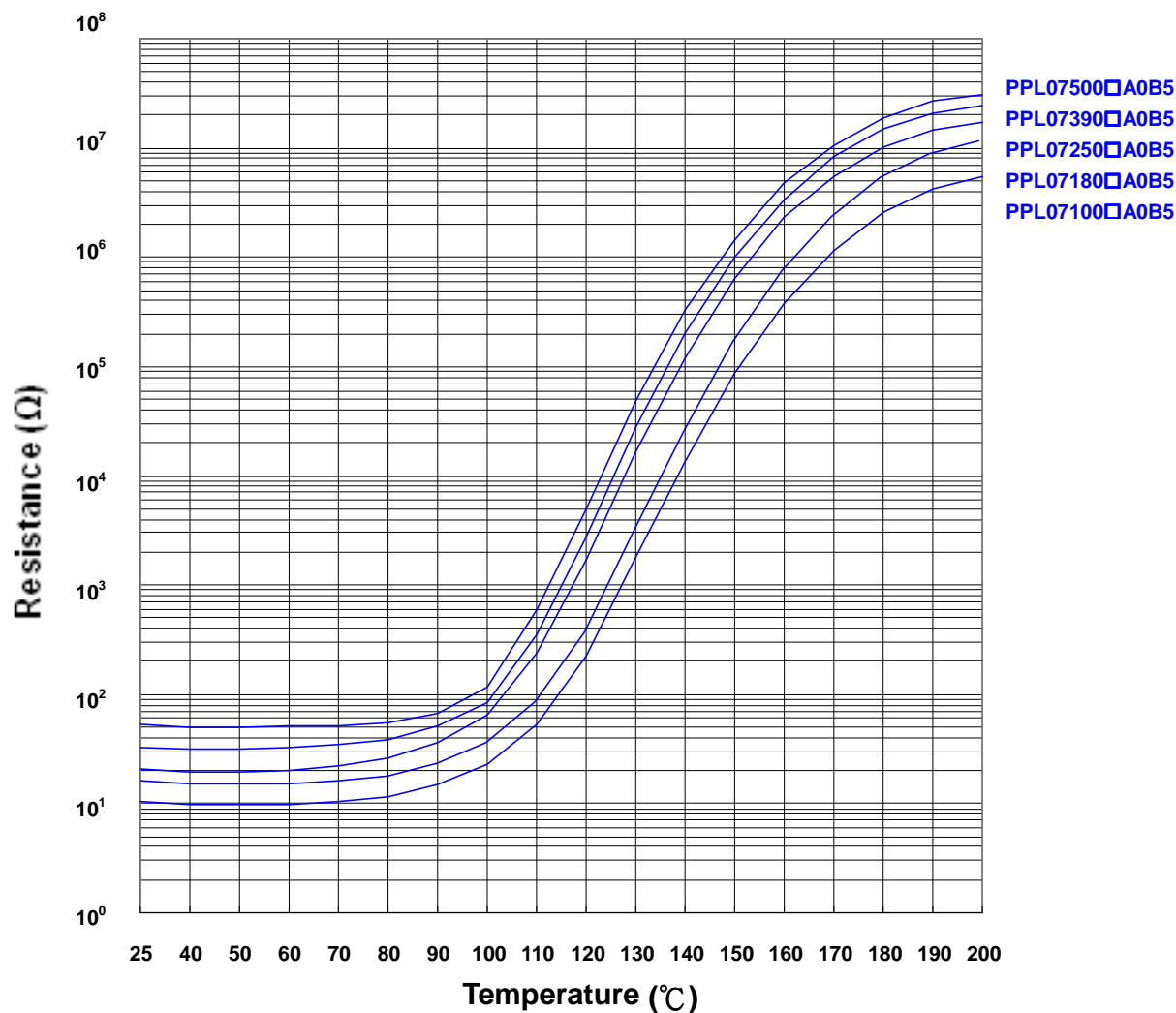

## ■ Circuit for Typical Application

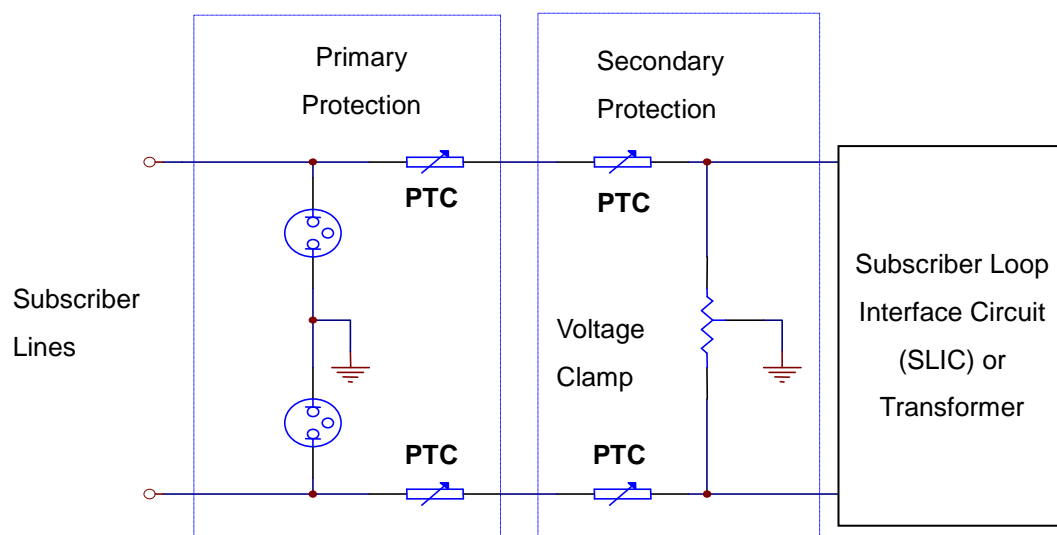

# CPTC Thermistor: Twin SMD Type PPL Series

## Overload Protection for Telecom Application



### ■ Soldering Recommendation

- IR-Reflow Soldering Profile

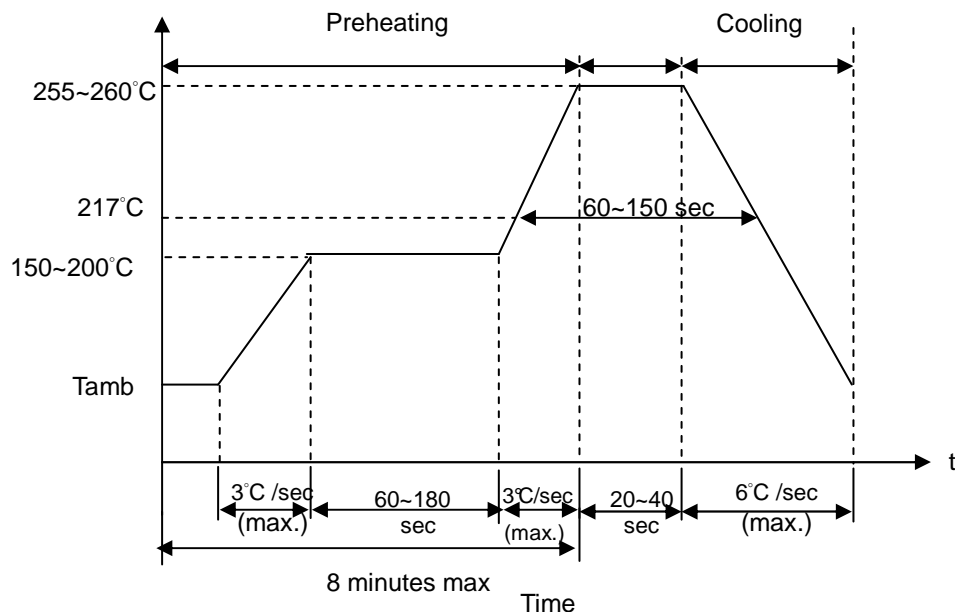

- Recommended Reworking Conditions With Soldering Iron

Item	Conditions
Temperature of Soldering Iron-tip	360°C (max.)
Soldering Time	3 sec (max.)
Diameter of Soldering Iron-tip	Φ3mm (max.)

# CPTC Thermistor: Twin SMD Type PPL Series

## Overload Protection for Telecom Application



### ■ Reliability

Item	Standard	Test conditions / Methods	Specifications															
Solderability	IEC60068-2-58	245±5°C , 3±0.3 sec.	At least 95% of terminal electrode is covered by new solder															
Resistance to Soldering Heat	IEC60068-2-58	255±5°C , 10±1 sec.	$\Delta R/R_{25}$   ≤ 20% No visible damage															
Vibration	IEC60068-2-6	Frequency range: 10~55Hz Amplitude: 0.75mm or 98m/S <sup>2</sup> Direction: 3 mutually perpendicular directions, 2hrs each.	$\Delta R/R_{25}$   ≤ 20% No visible damage															
Shock	IEC60068-2-27	Wave: half-sine $\Delta V$ :1.0m/s Acceleration: 50m/s <sup>2</sup> Pulse time:30ms	$\Delta R/R_{25}$   ≤ 20% No visible damage															
Rapid Change of Temperature	IEC60068-2-14	The rapid change conditions shown below shall be repeated 5 cycles. <table border="1" style="margin-left: auto; margin-right: auto;"> <thead> <tr> <th>Step</th> <th>Temperature(°C)</th> <th>Period(minutes)</th> </tr> </thead> <tbody> <tr> <td>1</td> <td>-40 ± 3</td> <td>30 ± 3</td> </tr> <tr> <td>2</td> <td>Room temperature</td> <td>5 ± 3</td> </tr> <tr> <td>3</td> <td>85 ± 2</td> <td>30 ± 3</td> </tr> <tr> <td>4</td> <td>Room temperature</td> <td>5 ± 3</td> </tr> </tbody> </table>	Step	Temperature(°C)	Period(minutes)	1	-40 ± 3	30 ± 3	2	Room temperature	5 ± 3	3	85 ± 2	30 ± 3	4	Room temperature	5 ± 3	$\Delta R/R_{25}$   ≤ 20% No visible damage
Step	Temperature(°C)	Period(minutes)																
1	-40 ± 3	30 ± 3																
2	Room temperature	5 ± 3																
3	85 ± 2	30 ± 3																
4	Room temperature	5 ± 3																
Climatic Sequence	IEC60738-1	+40 °C , 20%R.H X 24hrs → 100 °C X 16hrs → 25°C X 2hrs → +40 °C , 95%R.HX 24hrs → 0 °C X 2hrs → +40 °C , 95%R.HX 24hrs → 25 °C X (1~2)hrs	$\Delta R/R_{25}$   ≤ 20% No visible damage															
High Temperature Storage	IEC60068-2-2	60°C, for 1000 hrs	$\Delta R/R_{25}$   ≤ 20% No visible damage															
High Temperature Continuous Load	IEC60738-1	60°C, Vmax, It<l<lmax for 1000 hrs	$\Delta R/R_{25}$   ≤ 20% No visible damage															
Damp Heat, Steady State	IEC60068-2-3	40±2°C, 90~95%RH, for 1000±2 hrs	$\Delta R/R_{25}$   ≤ 20% No visible damage															
Over Current	Specification Standard	220Vrms, 3A, 60s on and 600s off , x20 cycles	$\Delta R/R_{25}$   ≤ 20% No visible damage															
Power Contact	ITU-T K.20 9.4	230Vrms,10Ω, 15Min	$\Delta R/R_{25}$   ≤ 20% No visible damage															
Lightning Surge	ITU-T K30 4.2.5	DC:1.0KV, 10/1000μs,25A,x30 cycles DC:1.5KV, 10/310μs,37.5A,x10cycles	$\Delta R/R_{25}$   ≤ 20% No visible damage															
Power Induction	Specification Standard	650Vrms, 600Ω, 1s on and 60s off x10 cycles	$\Delta R/R_{25}$   ≤ 20% No visible damage															

# CPTC Thermistor: Twin SMD Type PPL Series Overload Protection for Telecom Application



## ■ Packaging

### ● Taping Specification

(Unit: mm)

Index	Nominal dimensions	Tolerance
W	16.00	±0.30
P	16.00	±0.10
E	1.75	±0.10
F	7.50	±0.10
P2	2.00	±0.10
P0	4.00	±0.10
D0	1.50	+0.10/-0.00
D1	1.50	+0.10/-0.00
A0	8.4	±0.10
B0	8.9	±0.10
K0	9.3	±0.10
t	0.5	±0.05

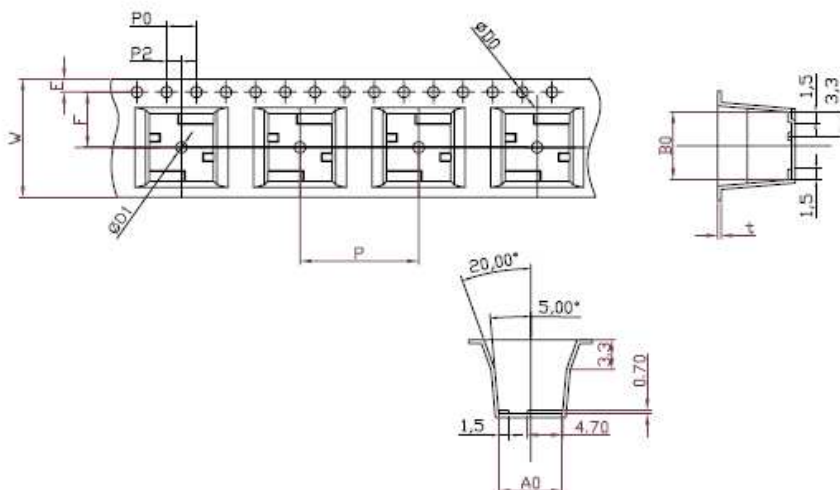

## ■ Quantity

Reel packing: 400 pcs / reel

(Unit: mm)

Item	Nominal dimensions	Tolerance
D	330	±5
W	17.5	±0.5
t	5	±0.5
D1	75	±1.5

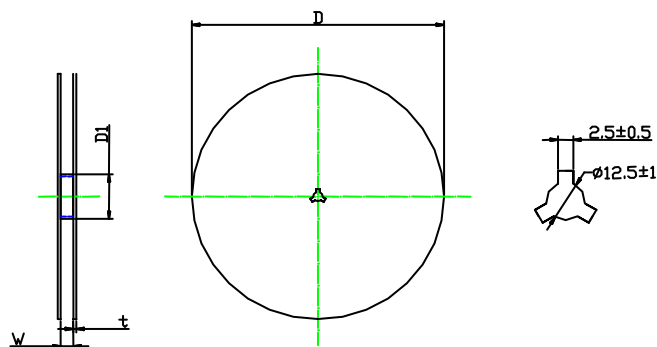

## ■ Storage condition of products

- Storage Conditions :
  1. Storage Temperature : -10°C ~+40°C
  2. Relative Humidity : ≤75%RH
  3. Keep away from corrosive atmosphere and sunlight.
- Period of Storage: 1 year.