

G7100D Technical Data Sheet

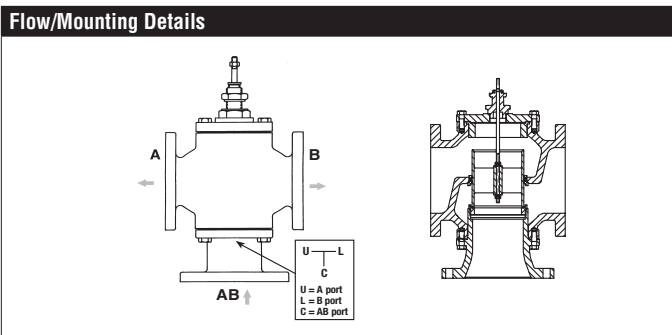

Technical Data	
Fluid	chilled or hot water, up to 60% glycol
Flow characteristic	linear
Controllable flow range	stem up - open AB – B
Valve Size [mm]	4" [100]
Pipe connection	125 lb flanged
Housing	Cast iron - ASTM A126 Class B
Stem	stainless steel
Stem seal	NLP EPDM (no lip packing)
Seat	Stainless steel AISI 316
Valve plug	bronze
Body Pressure Rating	ANSI Class 125, up to 175 psi below 150°F
ANSI Class	125
Number of Bolt Holes	8
Rangeability Sv	50:1
Cv	154
Weight	138.91 lb [63 kg]
Fluid Temp Range (water)	32...300°F [0...149°C]
Leakage rate	ANSI Class III
Servicing	repack/rebuild kits available



Application

This valve is typically used in Large Air Handling Units on heating or cooling coils. This valve is suitable for use in a hydronic system with variable flow. These valves are to be used in Diverting applications only.

Suitable Actuators

	Non-Spring	Spring	Electronic fail-safe
G7100D	EVB(X)	AF	AVKB(X)

Dimensions (Inches [mm])

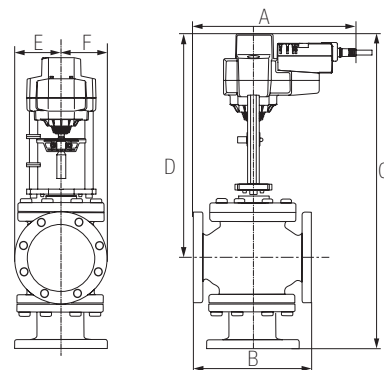

EVB, EVX, RVB, RVX

A	B	C	D	E	F
13.7" [349]	13.0" [330]	29.7" [754]	19.8" [502]	4.5" [114]	

Safety Notes

WARNING: This product can expose you to lead which is known to the State of California to cause cancer and reproductive harm. For more information go to www.p65warnings.ca.gov

Piping

The valves should be mounted in a weather-protected area in a location that is within the ambient limits of the actuator. Allow sufficient room for valve with actuator and for service. The preferred mounting position of the valve is with the valve stem vertical above the valve body, for maximum life. However, the assemblies can be mounted with valve stem vertical above the valve or up to 45° in relation to the horizontal pipe. The actuators should never be mounted underneath the valve, as condensation can build up and result in a failure of the actuators. Do not reverse flow direction.

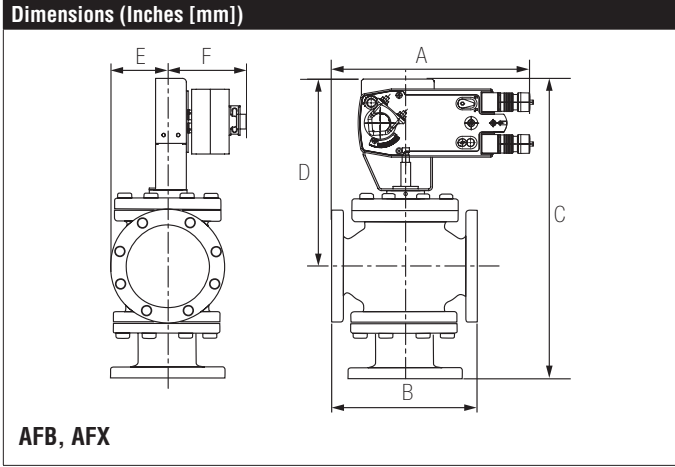

A	B	C	D	E	F
13.7" [349]	13.0" [330]	28.0" [711]	18.3" [464]	4.5" [114]	5.3" [135]

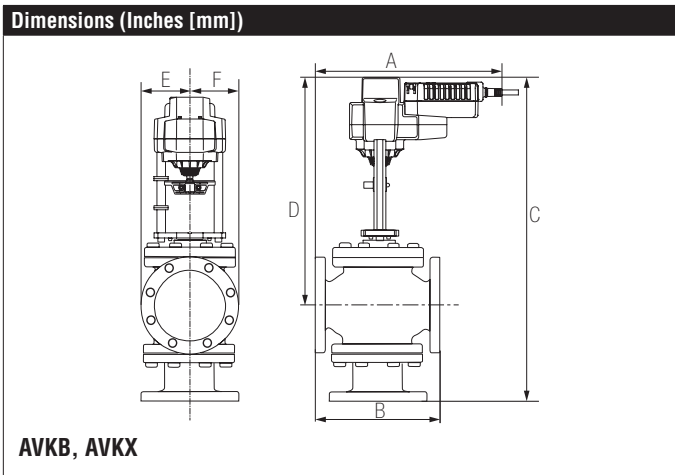

A	B	C	D	E	F
13.7" [349]	13.0" [330]	29.7" [754]	19.8" [502]	4.5" [114]	

AVKB24-MFT Technical Data Sheet

Modulating, Fail-Safe Operation, Linear, 24 V, Multi-Function Technology®



5-year warranty



Technical Data	
Power Supply	24 VAC, ±20%, 50/60 Hz, 24 VDC, ±10%
Power consumption in operation	5 W
Power consumption in rest position	2 W
Transformer sizing	9.5 VA (class 2 power source)
Electrical Connection	18 GA plenum cable, 3 ft [1 m], with 1/2" conduit connector, degree of protection NEMA 2 / IP54
Overload Protection	electronic throughout full stroke
Electrical Protection	actuators are double insulated
Operating Range	2...10 V (default), 4...20 mA w/ ZG-R01 (500 Ω, 1/4 W resistor), variable (VDC, PWM, on/off, floating point)
Operating range Y variable	Start point 0.5...30 V End point 2.5...32 V
Input Impedance	100 kΩ for 2...10 V (0.1 mA), 500 Ω for 4...20 mA, 1500 Ω for PWM, On/Off and Floating point
Position Feedback	2...10 V
Stroke	1.25" [32 mm]
Actuating force motor	450 lbf [2000 N]
Direction of motion motor	selectable with switch
Direction of motion fail-safe	reversible with switch
Position indication	Mechanically, with pointer
Manual override	5 mm hex crank (3/16" Allen), supplied
Running Time (Motor)	default 90 s, variable 90...150 s
Running time fail-safe	<35 s
Bridging time	2 s delay before fail-safe activates
Pre-charging time	5...20 s
Ambient humidity	max. 95% r.H., non-condensing
Ambient temperature	-22...122°F [-30...50°C]
Storage temperature	-40...176°F [-40...80°C]
Degree of Protection	IP54, NEMA 2, UL Enclosure Type 2
Housing material	Die cast aluminium and plastic casing
Agency Listing	cULus acc. to UL60730-1A/-2-14, CAN/CSA E60730-1:02, CE acc. to 2014/30/EU and 2014/35/EU
Noise level, motor	60 dB(A)
Noise level, fail-safe	60 dB(A)
Servicing	maintenance-free
Quality Standard	ISO 9001
Weight	6.39 lb [2.9 kg]

† Use flexible metal conduit. Push the listed conduit fitting device over the actuator's cable to butt against the enclosure. Screw in conduit connector. Jacket the actuators input wiring with listed flexible conduit. Properly terminate the conduit in a suitable junction box. Rated impulse Voltage 800V. Type of action 1. Control pollution degree 3.

Date created, 01/27/2020 - Subject to change. © Belimo Aircontrols (USA), Inc.

Wiring Diagrams

INSTALLATION NOTES

- Actuators may be connected in parallel. Power consumption and input impedance must be observed.
- Actuators may also be powered by 24 VDC.
- A 500 Ω resistor (ZG-R01) converts the 4 to 20 mA control signal to 2 to 10 VDC.
- Control signal may be pulsed from either the Hot (Source) or Common (Sink) 24 VAC line.
- For triac sink the common connection from the actuator must be connected to the hot connection of the controller. Contact closures A & B also can be triacs. A & B should both be closed for the triac source and open for triac sink.
- Actuators with plenum cable do not have numbers; use color codes instead.
- Meets cULus requirements without the need of an electrical ground connection.
- WARNING! LIVE ELECTRICAL COMPONENTS!** During installation, testing, servicing and troubleshooting of this product, it may be necessary to work with live electrical components. Have a qualified licensed electrician or other individual who has been properly trained in handling live electrical components perform these tasks. Failure to follow all electrical safety precautions when exposed to live electrical components could result in death or serious injury.

24 VAC Transformer

◆	3	18
Blk (1)	- Common	
Red (2)	↑ Hot	
Wht (3)	↓ Y ₁ Input	
Org (5)	U Output	

On/Off

24 VAC Transformer

◆	2	18
Blk (1)	- Common	
Red (2)	+ Hot	
Wht (3)	Y ₁ Input	
Pnk (4)	Y ₂ Input	
Org (5)	U Output	

Floating Point

24 VAC Transformer

◆	3	18
Blk (1)	- Common	
Red (2)	+ Hot	
Wht (3)	Y ₁ Input	
Org (5)	U Output	

VDC / 4 to 20 mA

24 VAC Transformer (AC Only)

◆	18
Blk (1)	- Common
Red (2)	+ Hot
Wht (3)	Y ₁ Input
Org (5)	U Output

Functions	a	b	c	
Min	0% ←	↘	↘	↑
Mid	50% ←	↘	↘	↓
Max	100% ←	↘	↘	↑
Normal	Control mode acc. to Y	↘	↘	↓

Override Control Min, Mid, Max Positions

Date created, 01/27/2020 - Subject to change. © Belimo Aircontrols (USA), Inc.

800-543-9038 USA

866-805-7089 CANADA

203-791-8396 LATIN AMERICA / CARIBBEAN