



UZ0103

Preliminary

TRIAC

1A TRIAC

DESCRIPTION

The UTC **UZ0103** is a 1A triac, it is suitable for general purpose AC switching applications, fan speed controllers and home appliances.

FEATURES

- * $I_{GT} \leq 3\text{mA}$ (I-II-III), $I_{GT} \leq 5\text{mA}$ (IV)
- $I_{TSM} \leq 8\text{A}$ ($t=20\text{ms}$), $I_{TSM} \leq 8.5\text{A}$ ($t=16.7\text{ms}$)
- $I_{T(RMS)} \leq 1\text{A}$

SYMBOL

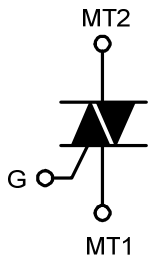

ORDERING INFORMATION

| Ordering Number | | Package | Pin Assignment | | | Packing |
|-----------------|-----------------|---------|----------------|------|------|-----------|
| Lead Free | Halogen Free | | 1 | 2 | 3 | |
| - | UZ0103G-x-AA3-R | SOT-223 | MT1 | MT2 | GATE | Tape Reel |
| UZ0103L-x-T92-B | UZ0103G-x-T92-B | TO-92 | MT1 | GATE | MT2 | Tape Box |
| UZ0103L-x-T92-K | UZ0103G-x-T92-K | TO-92 | MT1 | GATE | MT2 | Bulk |

| | | |
|-----------------|------------------|---|
| UZ0103G-x-AA3-R | (1)Packing Type | (1) R: Tape Reel |
| | (2)Package Type | (2) AA3: SOT-223, T92: TO-92 |
| | (3)Peak Voltage | (3) 6: 600V, 8: 800V |
| | (4)Green Package | (4) G: Halogen Free and Lead Free, L: Lead Free |

SENSITIVITY AND TYPE

| VOLTAGE CODE | VOLTAGE | | SENSITIVITY | TYPE |
|--------------|---------|------|-------------|----------|
| | 600V | 800V | | |
| 6 | ⊙ | | 3mA | STANDARD |
| 8 | | ⊙ | 3mA | STANDARD |

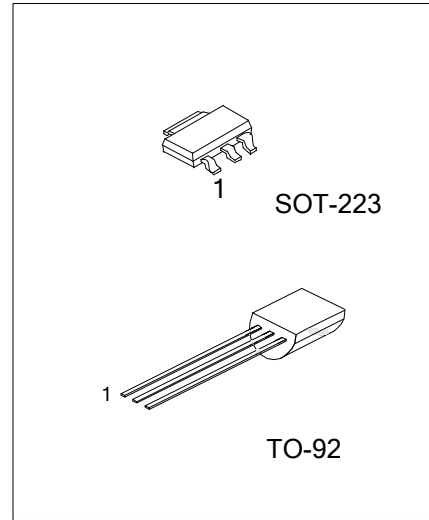

MARKING

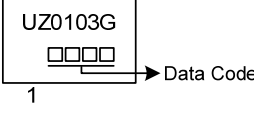
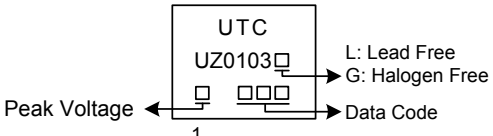
| SOT-223 | TO-92 |
|---|--|
|  <p>UZ0103G □□□□ → Data Code 1</p> |  <p>UTC UZ0103□ □□□□ → Data Code 1</p> <p>Peak Voltage ←</p> <p>L: Lead Free G: Halogen Free</p> |

■ ABSOLUTE MAXIMUM RATINGS

| PARAMETER | | SYMBOL | RATINGS | UNIT |
|---|---|--------------|----------|------------------------|
| Repetitive Peak Off-State Voltage | UZ0103-6 | V_{DRM} | 600 | V |
| | UZ0103-8 | | 800 | V |
| Repetitive Peak Reverse Voltage | UZ0103-6 | V_{RRM} | 600 | V |
| | UZ0103-8 | | 800 | V |
| RMS On-State Current (full sine wave) | $T_L=50^\circ\text{C}$ | $I_{T(RMS)}$ | 1 | A |
| Non Repetitive Surge Peak On-State Current (full cycle, T_J initial= 25°C) | F=50Hz, $t=20\text{ms}$ | I_{TSM} | 8 | A |
| | F=60Hz, $t=16.7\text{ms}$ | | 8.5 | A |
| I^2t Value for Fusing | $t_p=10\text{ms}$ | I^2t | 0.35 | A^2s |
| Critical Rate of Rise of On-State Current: $I_G=2*I_{GT}$, $t_r \leq 100\text{ns}$ | F=120Hz, $T_J=125^\circ\text{C}$ | di/dt | 20 | $\text{A}/\mu\text{s}$ |
| Peak Gate Current | $t_p=20\mu\text{s}$, $T_J=125^\circ\text{C}$ | I_{GM} | 1 | A |
| Average Gate Power Dissipation | $T_J=125^\circ\text{C}$ | $P_{G(AV)}$ | 1 | W |
| Operating Junction Temperature | | T_J | -40~+125 | $^\circ\text{C}$ |
| Storage Junction Temperature | | T_{STG} | -40~+150 | $^\circ\text{C}$ |

Note: Absolute maximum ratings are those values beyond which the device could be permanently damaged. Absolute maximum ratings are stress ratings only and functional device operation is not implied.

■ THERMAL RESISTANCES

| PARAMETER | | SYMBOL | RATINGS | UNIT |
|---------------------|---------|---------------|---------|---------------------------|
| Junction to Ambient | TO-92 | θ_{JA} | 150 | $^\circ\text{C}/\text{W}$ |
| | SOT-223 | | 60 | $^\circ\text{C}/\text{W}$ |
| Junction to Case | TO-92 | θ_{JC} | 60 | $^\circ\text{C}/\text{W}$ |
| | SOT-223 | | 25 | $^\circ\text{C}/\text{W}$ |

Note: S=Copper surface under tab

■ ELECTRICAL CHARACTERISTICS ($T_J=25^\circ\text{C}$, unless otherwise specified)

| PARAMETER | SYMBOL | TEST CONDITIONS | QUADRANT | MIN | TYP | MAX | UNIT |
|---|-----------------------|--|-------------------------|-----|-----|------|------------------------|
| Repetitive Peak Off-State or Reverse Current | I_{DRM} , I_{RRM} | $V_{DRM}=V_{RRM}$ | $T_J=25^\circ\text{C}$ | | | 5 | μA |
| | | | $T_J=125^\circ\text{C}$ | | | 0.5 | mA |
| Gate Trigger Current (Note 1) | I_{GT} | $V_D=12\text{V}$, $R_L=30\Omega$ | I-II-III | | | 3 | mA |
| | | | IV | | | 5 | mA |
| Gate Trigger Voltage | V_{GT} | | ALL | | | 1.3 | V |
| Gate Non-Trigger Voltage | V_{GD} | $V_D=V_{DRM}$, $R_L=3.3\text{k}\Omega$, $T_J=125^\circ\text{C}$ | ALL | 0.2 | | | V |
| Holding Current (Note 2) | I_H | $I_T=50\text{mA}$ | | | | 7 | mA |
| Latching Current | I_L | $I_G=1.2I_{GT}$ | I-III-IV | | | 7 | mA |
| | | | II | | | 15 | mA |
| Rise of Off-State Voltage (Note 2) | dV_D/dt | $V_D=67\%V_{DRM}$, Gate Open, $T_J=110^\circ\text{C}$ | | 10 | | | $\text{V}/\mu\text{s}$ |
| Rise of Off-State Voltage at Commutation (Note 2) | $(dV_{COM}/dt)_C$ | $(di/dt)_C=0.44\text{A}/\text{ms}$, $T_J=110^\circ\text{C}$ | | 0.5 | | | $\text{V}/\mu\text{s}$ |
| On-State Voltage (Note 2) | V_{TM} | $I_{TM}=1.4\text{A}$, $t_p=380\mu\text{s}$, $T_J=25^\circ\text{C}$ | | | | 1.56 | V |
| Dynamic Resistance (Note 2) | R_D | Dynamic resistance, $T_J=125^\circ\text{C}$ | | | | 400 | $\text{m}\Omega$ |

Notes: 1. Minimum I_{GT} is guaranteed at 5% of I_{GT} max.

2. For both polarities of MT2 referenced to MT1.

UTC assumes no responsibility for equipment failures that result from using products at values that exceed, even momentarily, rated values (such as maximum ratings, operating condition ranges, or other parameters) listed in products specifications of any and all UTC products described or contained herein. UTC products are not designed for use in life support appliances, devices or systems where malfunction of these products can be reasonably expected to result in personal injury. Reproduction in whole or in part is prohibited without the prior written consent of the copyright owner. The information presented in this document does not form part of any quotation or contract, is believed to be accurate and reliable and may be changed without notice.