

Remote I/O R7K4D Series

HI-SPEED LINK SYSTEM I/O MODULE

(PNP discrete input & NPN transistor output, 16 points each, e-CON connector, HLS use)

Functions & Features

- 16 points PNP discrete input & 16 points NPN transistor output module for HLS

HLS is the abbreviation for "Hi-speed Link System" of Step Technica Co., Ltd.

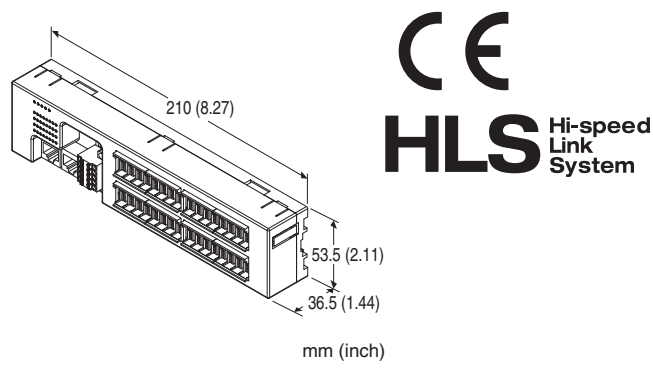

MODEL: R7K4DH-1-DAC32A-R[1]

ORDERING INFORMATION

- Code number: R7K4DH-1-DAC32A-R[1]
- Specify a code from below for [1].
(e.g. R7K4DH-1-DAC32A-R/H/Q)
- Specify the specification for option code /Q
(e.g. /C01)

TERMINAL BLOCK

- 1: Tension clamp terminal block for power supply
RJ-45 Modular jack for communication
e-CON connector for I/O

I/O TYPE

DAC32A: PNP discrete input & NPN transistor output, 16 points each

POWER INPUT

DC Power

R: 24 V DC

(Operational voltage range 24 V \pm 10 %, ripple 10 %p-p max.)

[1] OPTIONS (multiple selections)

Communication Mode

blank: Full-duplex

/H: Half-duplex

Other Options

blank: none

/Q: Option other than the above (specify the specification)

SPECIFICATIONS OF OPTION: Q

COATING (For the detail, refer to M-System's web site.)

/C01: Silicone coating

/C02: Polyurethane coating

/C03: Rubber coating

GENERAL SPECIFICATIONS

Connection

HLS: RJ-45 Modular Jack

Power & Sensor excitation: Separable screwless spring terminal

I/O: e-CON connector

Housing material: Flame-resistant resin (gray)

Isolation: Input or output or sensor excitation to HLS or power to FE

Output at the loss of communication:

Output hold(*), Output clear

Selectable with the front DIP SW

(*): factory default setting

Status indicator LED: Power (green) turns on while the power is supplied.

Discrete I/O status indicator LED: Red LED turns on with I/O ON

HLS COMMUNICATION

Communication mode: Full-duplex or half-duplex

Network cable

Shielded cable:

Full-duplex communication:

ZHY262PS and ZHT262PS (Shinko Seisen Industry Co., Ltd.)

Half-duplex communication:

ZHY221PS (Shinko Seisen Industry Co., Ltd.)

Dual shielded cable:

ZHY262PBA (Shinko Seisen Industry Co., Ltd.)

Transmission distance:

12 Mbps: 100 meters (328 ft)

6 Mbps: 200 meters (656 ft)

3 Mbps: 300 meters (984 ft)

(Configurable with DIP SW; factory setting: 12 Mbps)

Terminating resistor: Built-in (Selected with the DIP SW; factory setting: disabled)

Status indicator: Run LED on in normal communication

Station address: Set with rotary switch

(Refer to the instruction manual for details.)

STANDARDS & APPROVALS

EU conformity:

EMC Directive

EMI EN 61000-6-4

EMS EN 61000-6-2

RoHS Directive

EN 50581

INPUT SPECIFICATIONS

Common: Negative common (PNP) per 16 points

Maximum inputs applicable at once: No limit (at 24V DC)

Sensor excitation: 24 V DC $\pm 10\%$; ripple 5 %p-p max.,
 ≤ 2 A (including discrete input load charge); rated current 8 A

ON voltage / current: ≥ 15 V DC (X0 through XF to GND) / ≥ 3.5 mA

OFF voltage / current: ≤ 5 V DC (X0 through XF to GND) / ≤ 1 mA

Input current: ≤ 5.5 mA per point at 24 V DC

Input resistance: Approx. 4.4 k Ω

ON delay: ≤ 0.5 msec.

OFF delay: ≤ 0.5 msec.

OUTPUT SPECIFICATIONS

Common: Negative common (NPN) per 16 points

Maximum outputs applicable at once: No limit (at 24 V DC)

Sensor Excitation: 24 V DC $\pm 10\%$, ripple 5 %p-p max.,
 ≤ 2 A (including discrete output load charge); rated current 8 A

Rated output current: 0.1 A per point, 1.6 A per common

Residual voltage: ≤ 1.2 V

Leakage current: ≤ 0.1 mA

ON delay: ≤ 0.2 msec.

OFF delay: ≤ 0.5 msec.

Overload current protection function: Limits the current value when overcurrent is detected

Overheat protection function: Turns OFF the outputs when overheat is detected

(When driving an inductive load, connect a diode in parallel with the load.)

INSTALLATION

Current consumption

•DC: Approx. 95 mA (rated current 8 A)

Operating temperature: -10 to +55°C (14 to 131°F)

Storage temperature: -20 to +65°C (-4 to +149°F)

Operating humidity: 30 to 90 %RH (non-condensing)

Atmosphere: No corrosive gas or heavy dust

Mounting: Surface or DIN rail (35 mm rail)

Weight: Approx. 185 g (0.41 lb)

PERFORMANCE

Insulation resistance: ≥ 100 M Ω with 500 V DC

Dielectric strength: 1500 V AC @ 1 minute (input or output or sensor excitation to HLS to power to FE)

MODEL: R7K4DH-1-DAC32A

EXTERNAL VIEW

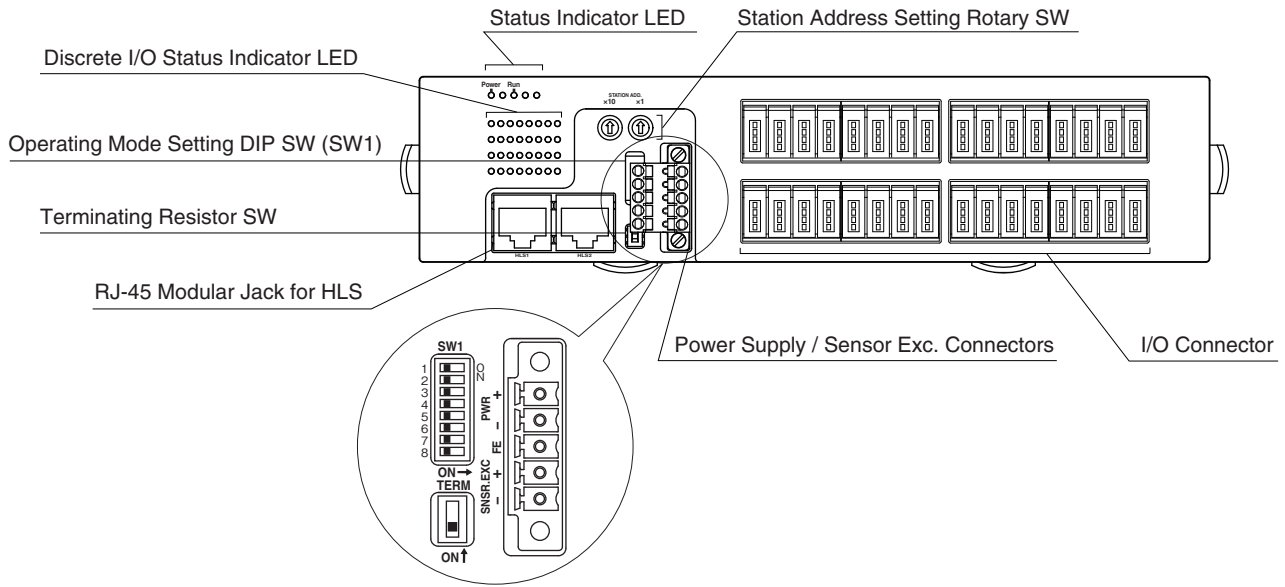

TERMINAL ASSIGNMENTS

I/O TERMINAL ASSIGNMENT

- e-CON connector

Recommended cable connector: 37104-()-000FL (3M Company)

(The cable connector is not included in the package.)

Specify wire size instead of (); refer to the specifications of the product.)

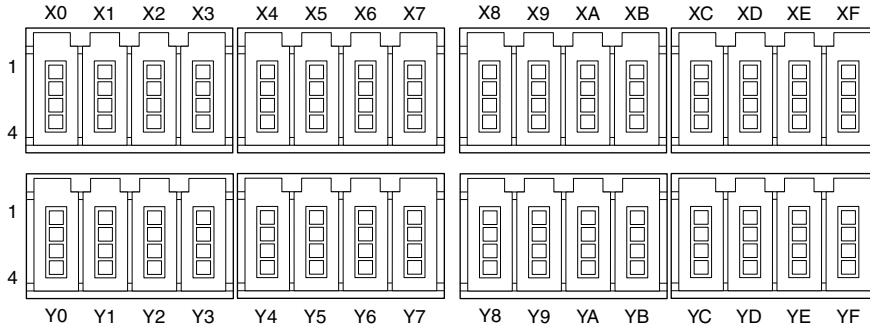

PIN No.	ID	FUNCTION	PIN No.	ID	FUNCTION
X0	1	+24V 24V DC	X8	1	+24V 24V DC
	2	NC Unused		2	NC Unused
	3	GND 0V		3	GND 0V
	4	X0 Input 0		4	X8 Input 8
X1	1	+24V 24V DC	X9	1	+24V 24V DC
	2	NC Unused		2	NC Unused
	3	GND 0V		3	GND 0V
	4	X1 Input 1		4	X9 Input 9
X2	1	+24V 24V DC	XA	1	+24V 24V DC
	2	NC Unused		2	NC Unused
	3	GND 0V		3	GND 0V
	4	X2 Input 2		4	XA Input 10
X3	1	+24V 24V DC	XB	1	+24V 24V DC
	2	NC Unused		2	NC Unused
	3	GND 0V		3	GND 0V
	4	X3 Input 3		4	XB Input 11
X4	1	+24V 24V DC	XC	1	+24V 24V DC
	2	NC Unused		2	NC Unused
	3	GND 0V		3	GND 0V
	4	X4 Input 4		4	XC Input 12
X5	1	+24V 24V DC	XD	1	+24V 24V DC
	2	NC Unused		2	NC Unused
	3	GND 0V		3	GND 0V
	4	X5 Input 5		4	XD Input 13
X6	1	+24V 24V DC	XE	1	+24V 24V DC
	2	NC Unused		2	NC Unused
	3	GND 0V		3	GND 0V
	4	X6 Input 6		4	XE Input 14
X7	1	+24V 24V DC	XF	1	+24V 24V DC
	2	NC Unused		2	NC Unused
	3	GND 0V		3	GND 0V
	4	X7 Input 7		4	XF Input 15

PIN No.	ID	FUNCTION	PIN No.	ID	FUNCTION
Y0	1	+24V 24V DC	Y8	1	+24V 24V DC
	2	NC Unused		2	NC Unused
	3	GND 0V		3	GND 0V
	4	Y0 Output 0		4	Y8 Output 8
Y1	1	+24V 24V DC	Y9	1	+24V 24V DC
	2	NC Unused		2	NC Unused
	3	GND 0V		3	GND 0V
	4	Y1 Output 1		4	Y9 Output 9
Y2	1	+24V 24V DC	YA	1	+24V 24V DC
	2	NC Unused		2	NC Unused
	3	GND 0V		3	GND 0V
	4	Y2 Output 2		4	YA Output 10
Y3	1	+24V 24V DC	YB	1	+24V 24V DC
	2	NC Unused		2	NC Unused
	3	GND 0V		3	GND 0V
	4	Y3 Output 3		4	YB Output 11
Y4	1	+24V 24V DC	YC	1	+24V 24V DC
	2	NC Unused		2	NC Unused
	3	GND 0V		3	GND 0V
	4	Y4 Output 4		4	YC Output 12
Y5	1	+24V 24V DC	YD	1	+24V 24V DC
	2	NC Unused		2	NC Unused
	3	GND 0V		3	GND 0V
	4	Y5 Output 5		4	YD Output 13
Y6	1	+24V 24V DC	YE	1	+24V 24V DC
	2	NC Unused		2	NC Unused
	3	GND 0V		3	GND 0V
	4	Y6 Output 6		4	YE Output 14
Y7	1	+24V 24V DC	YF	1	+24V 24V DC
	2	NC Unused		2	NC Unused
	3	GND 0V		3	GND 0V
	4	Y7 Output 7		4	YF Output 15

■ POWER SUPPLY, SENSOR EXCITATION

Cable connector: TFMC1,5 / 5-STF-3,5
(Phoenix Contact) (included in the package)

Applicable wire size: 0.2 – 1.5 mm²; stripped length 10 mm

Recommended solderless terminal

- AI0,25–10YE 0.25 mm² (Phoenix Contact)
- AI0,34–10TQ 0.34 mm² (Phoenix Contact)
- AI0,5–10WH 0.5 mm² (Phoenix Contact)
- AI0,75–10GY 0.75 mm² (Phoenix Contact)
- A1–10 1.0 mm² (Phoenix Contact)
- A1,5–10 1.5 mm² (Phoenix Contact)

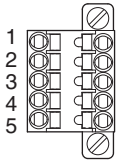

- | | |
|--------------|-------------------|
| 1. PWR+ | Power Supply |
| 2. PWR- | Power Supply |
| 3. FE | Functional earth |
| 4. SNSR.EXC+ | Sensor excitation |
| 5. SNSR.EXC- | Sensor excitation |

Note: The numbers marked on the connector have no relationship to the pin number of the unit.
Wire according to the instruction manual of the unit.

■ HLS

Recommended cable connector: TM21P-88P (Hirose Electric)
(not included in the package)

• Full-duplex communication

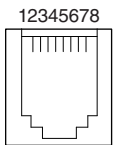

- | | |
|---------|----------------------------------|
| 1. NC | Unused |
| 2. NC | Unused |
| 3. TXD+ | Network (slave, transmission +) |
| 4. TXD- | Network (slave, transmission -) |
| 5. RXD+ | Network (master, transmission +) |
| 6. RXD- | Network (master, transmission -) |
| 7. NC | Unused |
| 8. SLD | Shield |

• Half-duplex communication

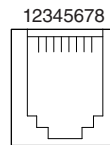

- | | |
|--------|-------------|
| 1. NC | Unused |
| 2. NC | Unused |
| 3. TR+ | Network (+) |
| 4. TR- | Network (-) |
| 5. NC | Unused |
| 6. NC | Unused |
| 7. NC | Unused |
| 8. SLD | Shield |

MODEL: R7K4DH-1-DAC32A

■ MASTER CONNECTION

• Full-duplex communication

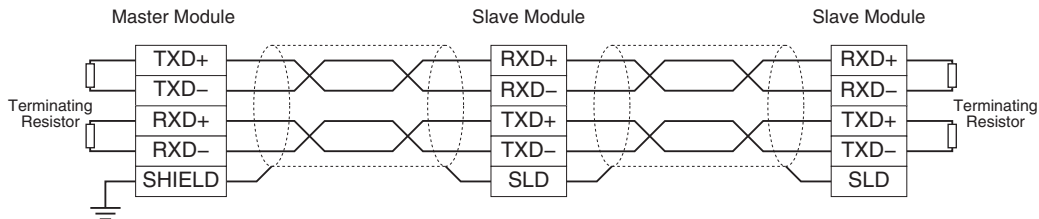

• Half-duplex communication

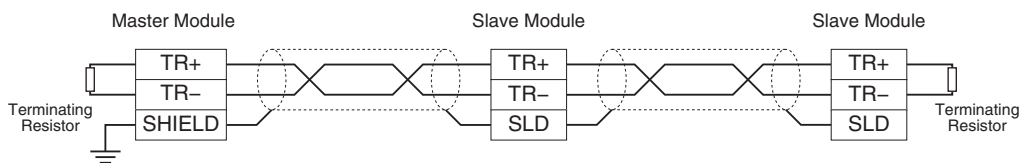

Note: Be sure to turn ON the switch of the terminating resistor located at both ends of the modules.

I/O DATA DESCRIPTIONS

■ DISCRETE I/O MODULE

• Di

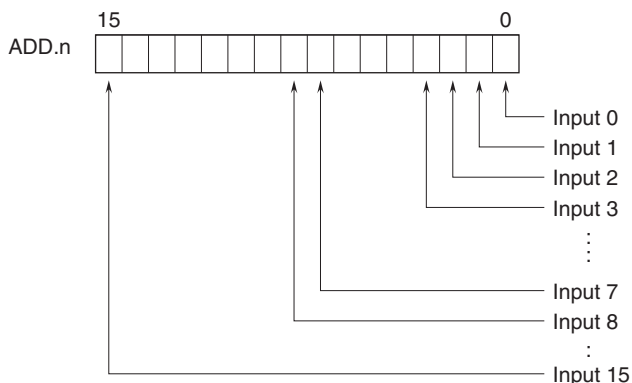

0: OFF
1: ON

• Do

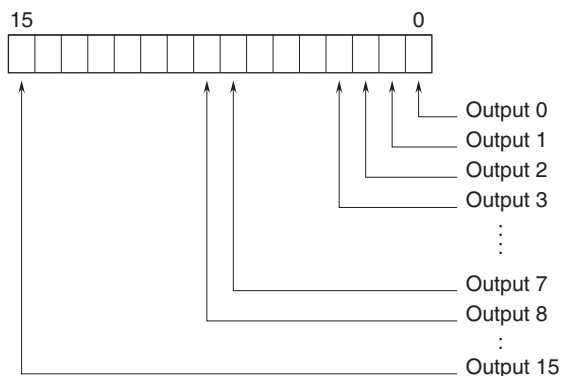

EXTERNAL DIMENSIONS unit: mm (inch)

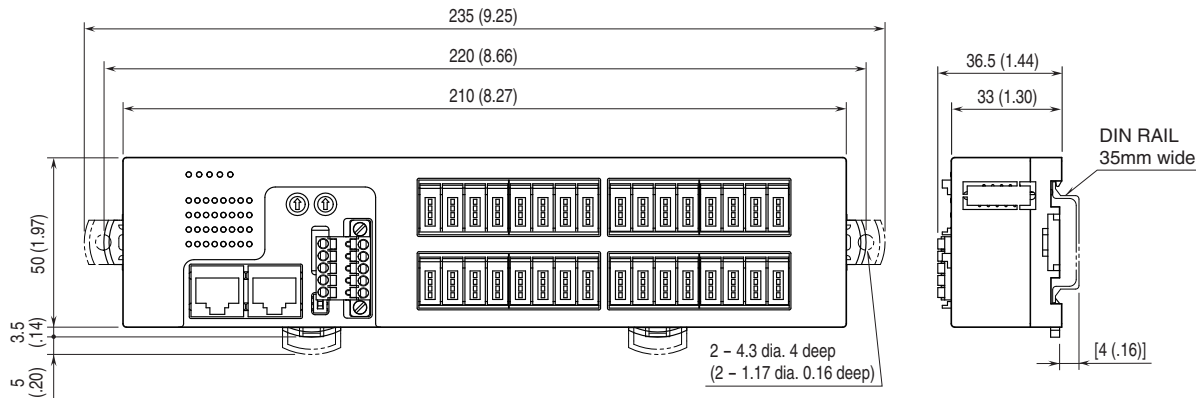

MODEL: R7K4DH-1-DAC32A

MOUNTING REQUIREMENTS unit: mm (inch)

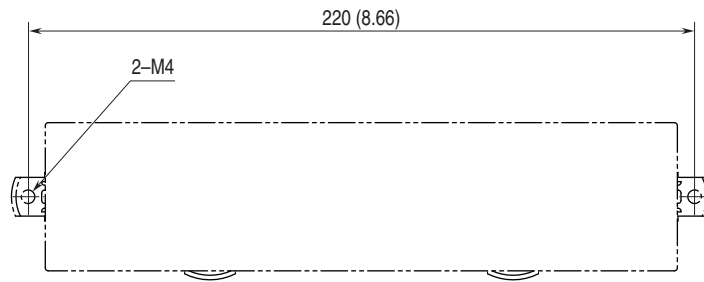

SCHEMATIC CIRCUITRY & CONNECTION DIAGRAM

Note: In order to improve EMC performance, bond the FE terminal to ground.

Caution: FE terminal is NOT a protective conductor terminal.

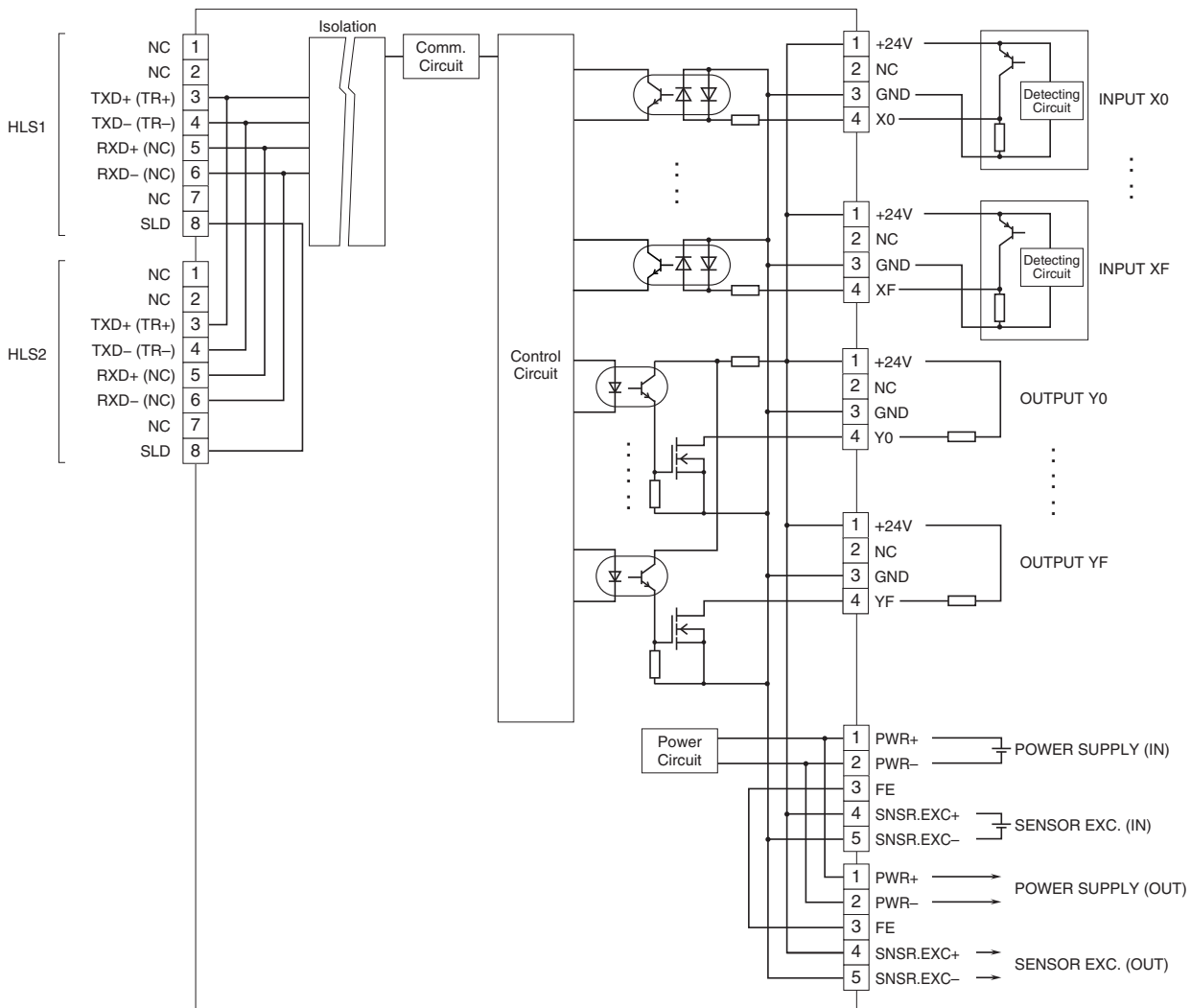

■ 2-Wire Sensor

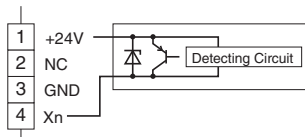



Specifications are subject to change without notice.