

**Limit Alarms M-PAC**

**2-WIRE TRANSMITTER LIMIT ALARM**

**MODEL MP1100-1123**

**MODEL & SUFFIX CODE SELECTION**

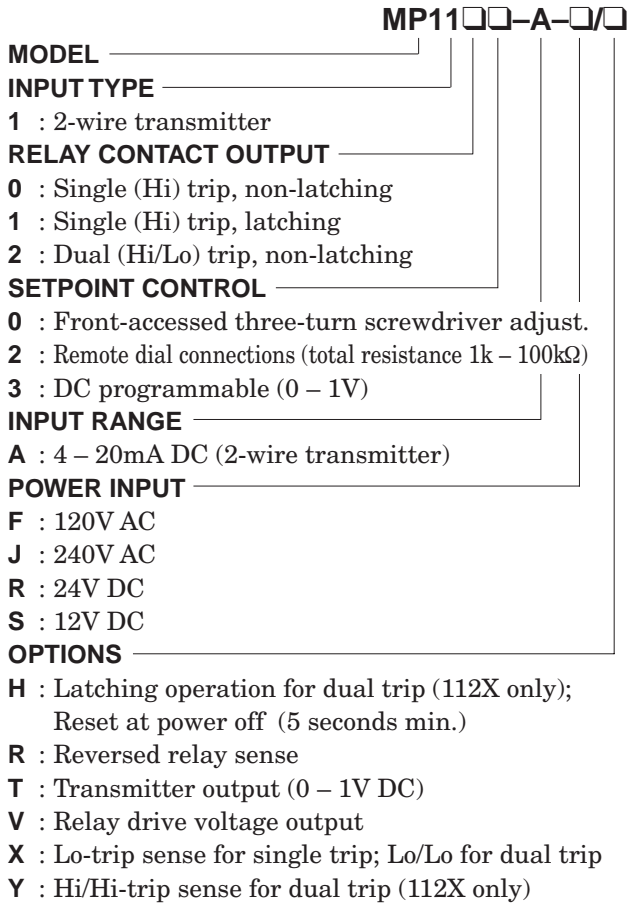

**ORDERING INFORMATION**

Specify code number. (e.g. MP1100-A-F/T/X)

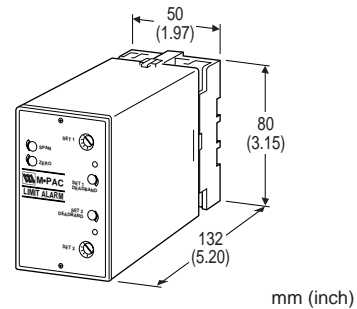

**Functions & Features**

- Supplying power to 2-wire current loop and providing relay contact closure(s) at a preset input level
- Single, latching or dual setpoint • Failsafe operation available • Deadband adjustable from 1 to 100%
- Indicator LED provided

**Typical Applications**

- Annunciator • Various alarm applications

**GENERAL SPECIFICATIONS**

**Construction:** plug-in

**Connection:** M3.5 screw terminals on base socket

**Housing material:** flame-resistant resin (black)

**Isolation:** input to output to power  
(non-isolated between I/O with Option V)

**Zero/span adjustments:** ±5% (front)

**Setpoint adjustments:** front accessed three-turn screwdriver, remote dial potentiometer or DC input

**Deadband adjustments:** front accessed single-turn screwdriver; 1 – 100%

**Front LEDs:** red lights turn on at a tripped condition

**Power ON timer:** relays de-energized for approx. 2 seconds after power is turned on.

**INPUT & OUTPUT****■SUPPLY OUTPUT****Output voltage:** 24 – 28V DC with no load**Current rating:** 22mA DC maximum**•Shortcircuit Protection****Current limited:** 35mA maximum**■INPUT:** 4 – 20mA DC**Input resistance:** 250Ω**■REMOTE SETPOINT INPUT****MP11X2:** potentiometer; any value of 1k – 100kΩ;  
excitation 4V**MP11X3:** 0 – 1V DC**■RELAY CONTACT OUTPUT****•Single/Latching:** isolated DPDT relay; de-energized  
at trip**•Dual:** isolated SPDT relay; energized at trip**Rating:** 120V AC @3A (cosφ=1)  
30V DC @3A (resistive load)**Relay life****Electrical:** 10<sup>5</sup> cycles**Mechanical:** 10<sup>7</sup> cyclesFor maximum relay life with inductive  
loads, external protection is recommended.**■VOLTAGE OUTPUT (Option V):** 24V DC average;  
Drives 1.2kΩ or greater coil impedance**■TRANSMITTER OUTPUT (Option T):** 0 – 1V DC;  
1mA max. (setpoint and process input)**INSTALLATION****Power input****AC:** operational voltage range: rating ±10%,  
50/60 ±2 Hz, approx. 2.5VA**DC:** operational voltage range: rating ±10%  
(ripple 10% p-p max.)

90mA at 24V, 180mA at 12V

**Operating temperature:** -5 to +60°C (23 to 140°F)**Storage temperature:** -20 to +85°C (-5 to +185°F)**Operating humidity:** 30 to 90% RH (non-condensing)**Mounting:** surface (DIN rail available for 11-pin base)**Dimensions****11-pin base:** W50×H80×D132 mm

(1.97"×3.15"×5.20")

See General Spec. Sheet Figure A.

**20-pin base:** W80×H101×D136 mm

(3.15"×3.98"×5.35")

See General Spec. Sheet Figure B.

**Weight:** 400 g (0.88 lbs)**PERFORMANCE in percentage of span****Repeatability:** ±0.2%**Temp. coefficient:** ±0.05%/°C (±0.027%/°F)**Response time:** 100 milliseconds, typical**Common mode rejection****60 Hz:** greater than 120 dB**DC:** greater than 140 dB**Line voltage effect:** ±0.1% over voltage range**Insulation resistance:** ≥100MΩ with 500V DC**Dielectric strength:** 1000V AC @1 minute

(input to output to power)

2000V AC @1 minute (output to ground)

# BLOCK DIAGRAM

## ■ SINGLE / LATCHING OUTPUT

### •11-pin Base

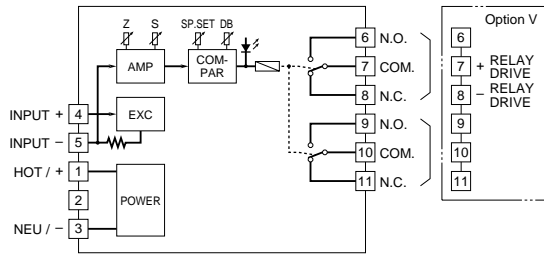

### •20-pin Base

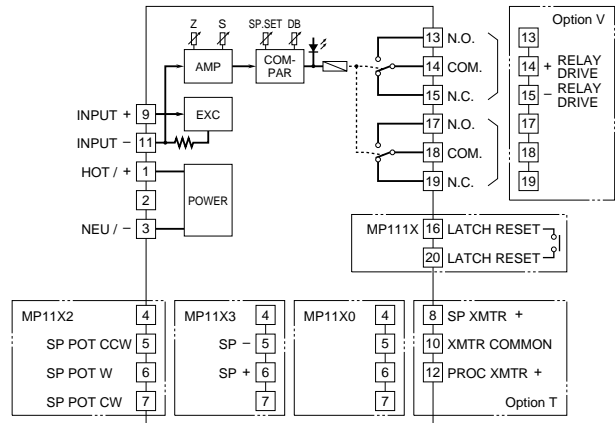

## ■ DUAL OUTPUT

### •11-pin Base

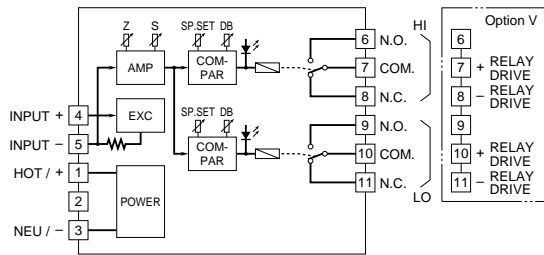

### •20-pin Base

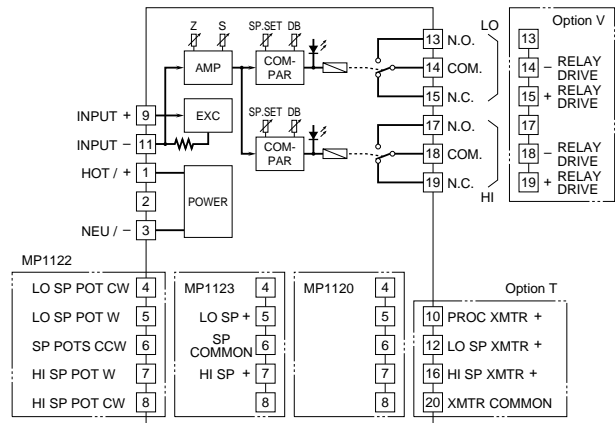

**TERMINAL ASSIGNMENT**

**■SINGLE OUTPUT**

PIN	MP1100	MP1100 w/Option T	MP1102	MP1102 w/Option T	MP1103	MP1103 w/Option T
1	POWER (Hot/+)	POWER (Hot/+)	POWER (Hot/+)	POWER (Hot/+)	POWER (Hot/+)	POWER (Hot/+)
2	No Connection	No Connection	No Connection	No Connection	No Connection	No Connection
3	POWER (Neu/-)	POWER (Neu/-)	POWER (Neu/-)	POWER (Neu/-)	POWER (Neu/-)	POWER (Neu/-)
4	INPUT +	No Connection	No Connection	No Connection	No Connection	No Connection
5	INPUT -	No Connection	SP Pot CCW	SP Pot CCW	SP -	SP -
6	N.O.	No Connection	SP Pot W	SP Pot W	SP +	SP +
7	COM *	No Connection	SP Pot CW	SP Pot CW	No Connection	No Connection
8	N.C. *	SP Xmtr +	No Connection	SP Xmtr +	No Connection	SP Xmtr +
9	N.O.	INPUT +	INPUT +	INPUT +	INPUT +	INPUT +
10	COM	Xmtr Common	No Connection	Xmtr Common	No Connection	Xmtr Common
11	N.C.	INPUT -	INPUT -	INPUT -	INPUT -	INPUT -
12		Proc Xmtr +	No Connection	Proc Xmtr +	No Connection	Proc Xmtr +
13		N.O.	N.O.	N.O.	N.O.	N.O.
14		COM *	COM *	COM *	COM *	COM *
15		N.C. *	N.C. *	N.C. *	N.C. *	N.C. *
16		No Connection	No Connection	No Connection	No Connection	No Connection
17		N.O.	N.O.	N.O.	N.O.	N.O.
18		COM	COM	COM	COM	COM
19		N.C.	N.C.	N.C.	N.C.	N.C.
20		No Connection	No Connection	No Connection	No Connection	No Connection

**KEYS**  
 N.O. = Normally Open  
 COM = Common  
 N.C. = Normally Closed  
 Proc = Process  
 Xmtr = Transmitter  
 SP = Setpoint  
 W = Wiper  
 CW = Clockwise  
 CCW = Counterclockwise

**\*Pins used for Option V**  
 20-pin = 14(+) - 15(-)  
 11-pin = 7(+) - 8(-)

**■LATCHING OUTPUT**

PIN	MP1110	MP1110 w/Option T	MP1112	MP1112 w/Option T	MP1113	MP1113 w/Option T
1	POWER (Hot/+)	POWER (Hot/+)	POWER (Hot/+)	POWER (Hot/+)	POWER (Hot/+)	POWER (Hot/+)
2	No Connection	No Connection	No Connection	No Connection	No Connection	No Connection
3	POWER (Neu/-)	POWER (Neu/-)	POWER (Neu/-)	POWER (Neu/-)	POWER (Neu/-)	POWER (Neu/-)
4	No Connection	No Connection	No Connection	No Connection	No Connection	No Connection
5	No Connection	No Connection	SP Pot CCW	SP Pot CCW	SP -	SP -
6	No Connection	No Connection	SP Pot W	SP Pot W	SP +	SP +
7	No Connection	No Connection	SP Pot CW	SP Pot CW	No Connection	No Connection
8	No Connection	SP Xmtr +	No Connection	SP Xmtr +	No Connection	SP Xmtr +
9	INPUT +	INPUT +	INPUT +	INPUT +	INPUT +	INPUT +
10	No Connection	Xmtr Common	No Connection	Xmtr Common	No Connection	Xmtr Common
11	INPUT -	INPUT -	INPUT -	INPUT -	INPUT -	INPUT -
12	No Connection	Proc Xmtr +	No Connection	Proc Xmtr +	No Connection	Proc Xmtr +
13	N.O.	N.O.	N.O.	N.O.	N.O.	N.O.
14	COM *	COM *	COM *	COM *	COM *	COM *
15	N.C. *	N.C. *	N.C. *	N.C. *	N.C. *	N.C. *
16	Latch Reset	Latch Reset	Latch Reset	Latch Reset	Latch Reset	Latch Reset
17	N.O.	N.O.	N.O.	N.O.	N.O.	N.O.
18	COM	COM	COM	COM	COM	COM
19	N.C.	N.C.	N.C.	N.C.	N.C.	N.C.
20	Latch Reset	Latch Reset	Latch Reset	Latch Reset	Latch Reset	Latch Reset

**KEYS**  
 N.O. = Normally Open  
 COM = Common  
 N.C. = Normally Closed  
 Proc = Process  
 Xmtr = Transmitter  
 SP = Setpoint  
 W = Wiper  
 CW = Clockwise  
 CCW = Counterclockwise

**\*Pins used for Option V**  
 20-pin = 14(+) - 15(-)

**■DUAL OUTPUT**

PIN	MP1120	MP1120 w/Option T	MP1122	MP1122 w/Option T	MP1123	MP1123 w/Option T
1	POWER (Hot/+)	POWER (Hot/+)	POWER (Hot/+)	POWER (Hot/+)	POWER (Hot/+)	POWER (Hot/+)
2	No Connection	No Connection	No Connection	No Connection	No Connection	No Connection
3	POWER (Neu/-)	POWER (Neu/-)	POWER (Neu/-)	POWER (Neu/-)	POWER (Neu/-)	POWER (Neu/-)
4	INPUT +	No Connection	Lo SP Pot CW	Lo SP Pot CW	No Connection	No Connection
5	INPUT -	No Connection	Lo SP Pot W	Lo SP Pot W	Lo SP +	Lo SP +
6	N.O.	No Connection	SP Pots CCW	SP Pots CCW	SP Common	SP Common
7	COM *	Hi Set	Hi SP Pot W	Hi SP Pot W	Hi SP +	Hi SP +
8	N.C. *	No Connection	Hi SP Pot CW	Hi SP Pot CW	No Connection	No Connection
9	N.O.	INPUT +	INPUT +	INPUT +	INPUT +	INPUT +
10	COM *	Lo Set	Proc Xmtr +	Proc Xmtr +	No Connection	Proc Xmtr +
11	N.C. *	INPUT -	INPUT -	INPUT -	INPUT -	INPUT -
12		Lo SP Xmtr +	No Connection	Lo SP Xmtr +	No Connection	Lo SP Xmtr +
13		N.O.	N.O.	N.O.	N.O.	N.O.
14		COM *	Lo Set	COM *	Lo Set	COM *
15		N.C. *	Lo Set	N.C. *	Lo Set	N.C. *
16		Hi SP Xmtr +	No Connection	Hi SP Xmtr +	No Connection	Hi SP Xmtr +
17		N.O.	N.O.	N.O.	N.O.	N.O.
18		COM *	Hi Set	COM *	Hi Set	COM *
19		N.C. *	Hi Set	N.C. *	Hi Set	N.C. *
20		Xmtr Common	No Connection	Xmtr Common	No Connection	Xmtr Common

**KEYS**  
 N.O. = Normally Open  
 COM = Common  
 N.C. = Normally Closed  
 Proc = Process  
 Xmtr = Transmitter  
 SP = Setpoint  
 W = Wiper  
 CW = Clockwise  
 CCW = Counterclockwise

**\*Pins used for Option V**  
 20-pin:  
 Hi Set = 19(+) - 18(-)  
 Lo Set = 15(+) - 14(-)  
 11-pin:  
 Hi Set = 7(+) - 8(-)  
 Lo Set = 10(+) - 11(-)

Specifications subject to change without notice.