

Fast Recovery Rectifier

1N3889 — 1N3893

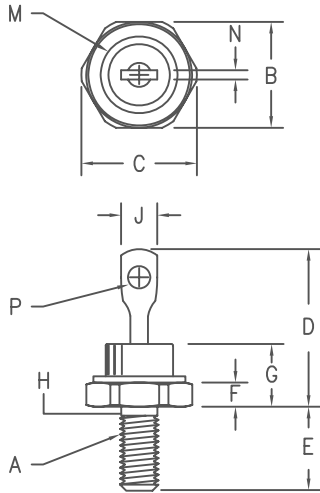

- Notes:
1. 10-32 UNF3A threads
 2. Full threads within 2 1/2 threads
 3. Standard Polarity: Stud is Cathode
Reverse Polarity: Stud is Anode

Dim.	Inches		Millimeter		Notes
	Minimum	Maximum	Minimum	Maximum	
A	---	---	---	---	1
B	.424	.437	10.77	11.10	
C	---	.505	---	12.82	
D	---	.800	---	20.32	
E	.422	.453	10.72	11.50	
F	.075	.175	1.90	4.44	
G	---	.405	---	10.29	
H	.163	.189	4.14	4.80	2
J	---	.250	---	6.35	
M	---	.424	---	10.77	Dia.
N	.020	.065	.510	1.65	
P	.060	---	1.52	---	Dia.

D0203AA (D04)

Microsemi Catalog Number	Working Peak Reverse Voltage	Repetitive Peak Reverse Voltage
1N3889*	50V	50V
1N3890*	100V	100V
1N3891*	200V	200V
1N3892*	300V	300V
1N3893*	400V	400V

*Add Suffix R For Reverse Polarity

- Fast Recovery Rectifier
- 175°C Junction Temperature
- V_{RRM} 100 to 400 Volts
- 12 Amps Current Rating

Electrical Characteristics

Average forward current	$I_F(AV)$ 12 Amps	$T_C = 100^\circ C$, Square wave, $R_{\theta JC} = 2.0^\circ C/W$
Maximum surge current	I_{FSM} 175 Amps	8.3 ms, half sine $T_C = 100^\circ C$
Max peak forward voltage	V_{FM} 1.50 Volts	$I_{FM} = 38A$ $T_J = 25^\circ C^*$
Max peak reverse current	I_{RM} 2 mA	V_{RRM} , $T_J = 150^\circ C$
Max peak reverse current	R_M 10 μA	V_{RRM} , $T_J = 25^\circ C$
Max reverse recovery time	t_{RR} 200 ns	$I_F = 1A$ dc, $V_R = 30V$, $di/dt = 25A/\mu s$, $T_C = 55^\circ C$
Typical junction capacitance	C_J 115 pF	$V_R = 10V$, $f = 1MHz$, $T_J = 25^\circ C$

*Pulse test: Pulse width 300 μs , Duty cycle 2%

Thermal and Mechanical Characteristics

Storage temp range	T_{STG}	$-65^\circ C$ to $175^\circ C$
Operating junction temp range	T_J	$-65^\circ C$ to $150^\circ C$
Max thermal resistance	$R_{\theta JC}$	$2.0^\circ C/W$ Junction to case
Mounting torque		12-15 inch pounds
Weight		.16 ounces (5.0 grams) typical

1N3889 — 1N3893

Figure 1
Typical Forward Characteristics

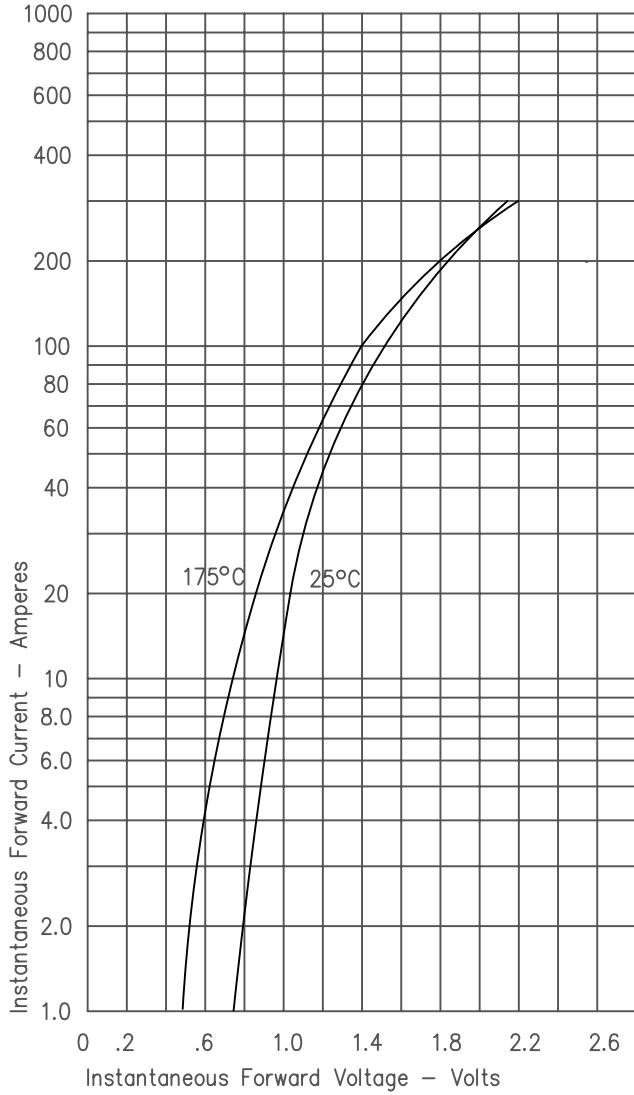

Figure 3
Typical Junction Capacitance

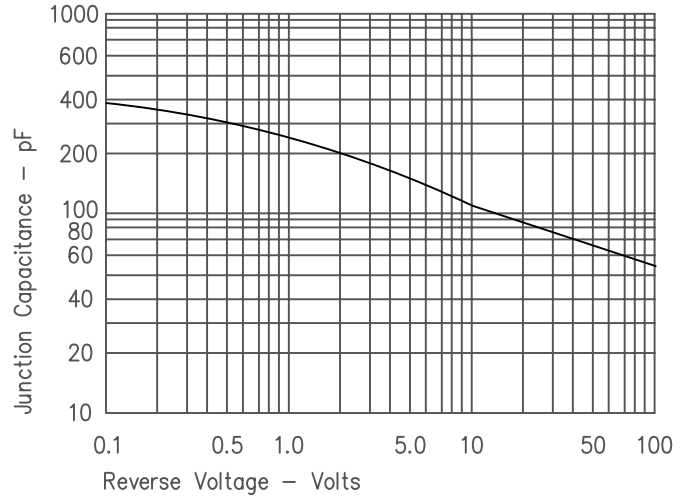

Figure 4
Forward Current Derating

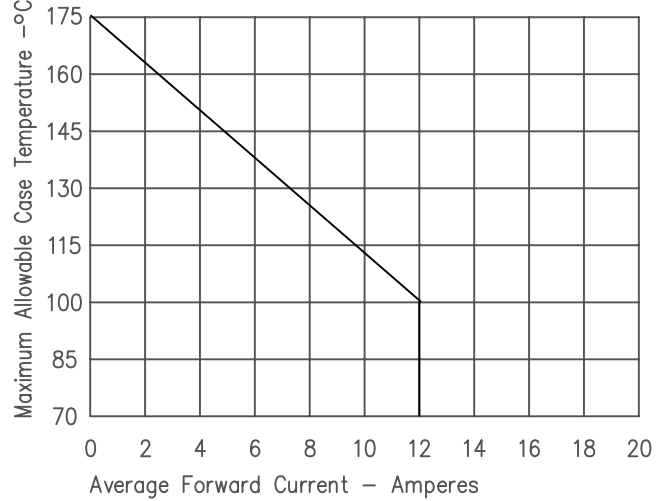

Figure 2
Typical Reverse Characteristics

