

# CGA6M3X7R2E224M200AE

TDK Item Description : CGA6M3X7R2E224MT\*\*\*S



Equivalent C3225X7R2E224M for Automotive

## Application & Main Feature

Automotive Grade ( Soft Termination )

## Series

CGA6(3225) [EIA CC1210]

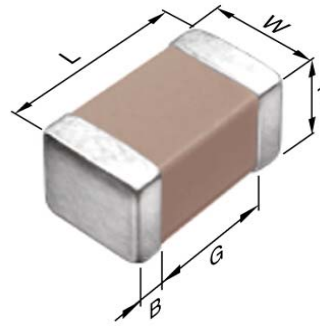

## Dimensions

- L 3.20mm +0.5,-0.4mm
- W 2.50mm +/-0.3mm
- T 2.00mm +0.3,-0.2mm
- B 0.20mm Min.
- G

## Temperature Characteristic

X7R (-55 to 125 degC +/-15%)

## Rated Voltage

2E (250Vdc)

## Capacitance

220nF

## Capacitance Tolerance

M (+/-20%)

## Dissipation Factor

3% Max.

## Insulation Resistance

2.27Gohm Min.

## AEC-Q200

Yes

## DC Bias Characteristic

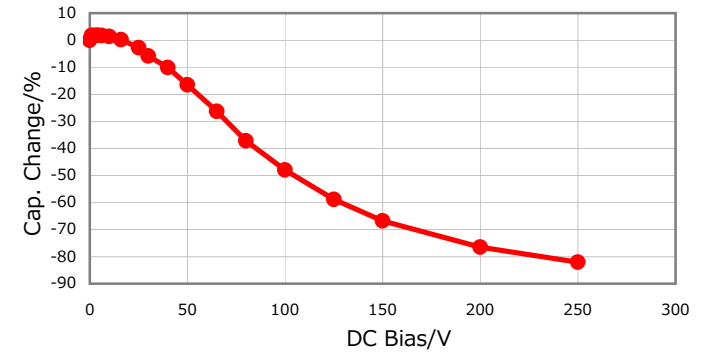

## |Z|, ESR vs. Freq. Characteristics

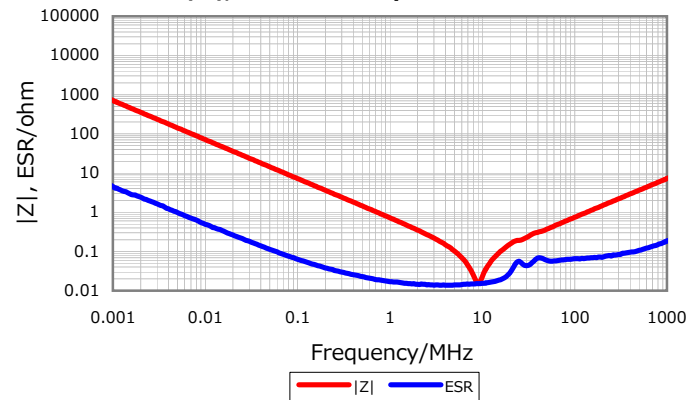

## Temperature Characteristics

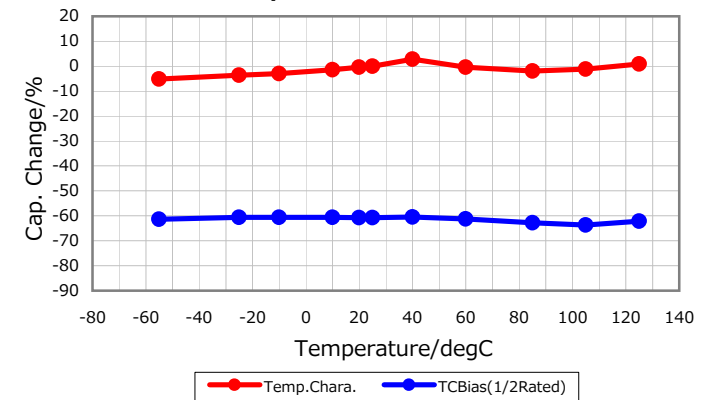

## Cap. vs. Freq. Characteristic

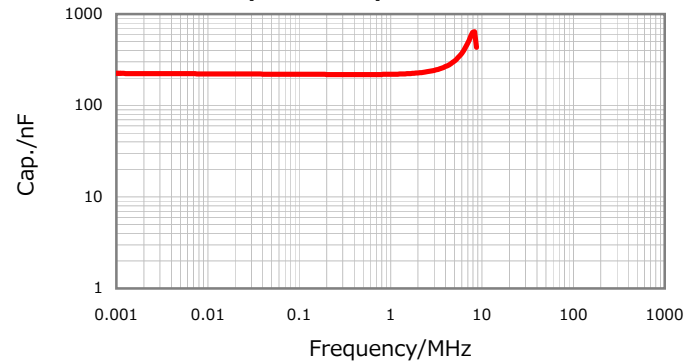

## Ripple Temperature Rise Characteristics

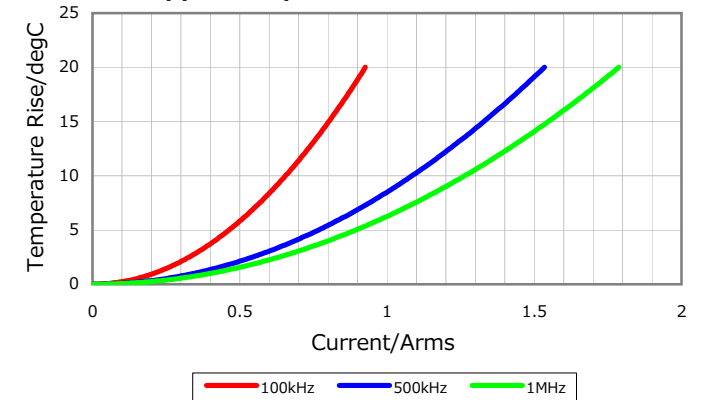

Characterization Sheet ( Multilayer Ceramic Chip Capacitors )



All specifications are subject to change without notice.

January 4, 2016