

SPECIFICATION

Part No. : **TG.08.0113**

Description : Monopole Passive Antenna
 Broadband frequency range for cellular and GNSS

Features : High efficiency at 698 to 960MHz, 1561MHz, 1575.42MHz, 1602MHz, 1710 to 2700MHz.
 360°rotatable with durable brass hinge.

Compatible with :

- 2G (GSM / DCS / PCS)
- 3G (CDMA / WCDMA / UMTS / HSPA)
- 4G (700LTE / 2700LTE)
- GNSS (GPS / GLONASS / BEIDOU)

Standard with SMA(M) connector
 Low profile with 72 ± 1.5mm Length
ROHS Compliant

Photo:



1. Introduction

The compact TG.08 with hinged rotatable SMA connector, is an impressively high efficiency monopole antenna, which provides wide coverage among cellular and GNSS frequencies.

With its cellular and GNSS function, plus compact design, TG.08 can fit and function perfectly with routers, vehicle tracking devices, telematics devices, and remote monitoring systems. It is also ideal for use with cellular modules with Assisted GPS functionality that can be implemented in various devices.

This 72mm long monopole antenna works efficiently from 700MHz to 2700MHz, widely covering 2G/3G/4G bands, as well as GPS/GLONASS/BEIDOU. At its maximum efficiency when connected to ground plane, it can achieve 73% and 67% at GPS and LTE bands, respectively.

As all monopole antennas, TG.08 works best while connecting directly to the ground-plane of the device main-board, or with the device's metal enclosure.

The robust brass hinge enables TG.08 to be oriented in all directions, providing users to maximize performance with minimum effort.

TG.08, the small antenna with surprisingly large efficiency, is surely the best candidate in the market for Cellular/GNSS combination terminal antennas.

2. Specification

Parameter										
Straight Position										
Band	700LTE	GSM	BEIDOU	GPS	GLONASS	DCS	PCS	UMTS/HSPA	2700LTE	
Frequency (MHz)	703~803	824~960	1561	1575.42	1602	1710~1880	1850~1990	1920~2170	2490~2690	
Average Gain (dBi)	In Free Space	-9.69	-8.70	-5.77	-5.44	-4.92	-3.84	-3.45	-3.62	-4.39
Efficiency (%)		10.75	13.50	26.48	28.56	32.24	41.40	45.18	43.46	36.73
Peak Gain (dBi)		-6.46	-4.93	-1.42	-1.07	-0.61	-0.02	0.66	0.33	0.36
Return Loss (dB)		< -2	< -3	< -6	< -6	< -10	< -10	< -10	< -8	< 4
Average Gain (dBi)	With 15x9cm Ground	-1.72	-4.35	-1.73	-1.67	-1.54	-1.38	-1.33	-1.70	-1.60
Efficiency (%)		67.86	37.27	67.08	68.13	70.22	72.83	73.67	67.77	69.40
Peak Gain (dBi)		1.24	-1.28	1.99	1.98	1.86	2.48	2.79	2.79	3.25
Return Loss (dB)		< -5		< -8						
Average Gain (dBi)	On 30x30cm Ground Metal Edge	-1.75	-2.55	-1.37	-1.34	-1.37	-1.31	-1.31	-1.70	-2.75
Efficiency (%)		66.98	56.27	73.02	73.38	72.97	74.02	74.05	67.83	53.12
Peak Gain (dBi)		1.53	0.13	3.95	3.86	3.82	2.82	3.22	3.20	2.22
Return Loss (dB)		< -5		< -9						
Average Gain (dBi)	On 30x30cm Ground Metal Center	-4.59	-3.46	-2.79	-2.82	-2.89	-2.71	-2.71	-2.94	-2.65
Efficiency (%)		35.71	45.52	52.63	52.25	51.38	53.68	53.56	50.89	54.39
Peak Gain (dBi)		-0.65	0.77	1.98	1.88	1.61	3.16	2.56	2.33	3.26
Return Loss (dB)		< -2		< -4						
Bent Position										
Average Gain (dBi)	In Free Space	-10.74	-10.14	-5.81	-5.48	-4.99	-4.03	-3.71	-4.00	-4.80
Efficiency (%)		8.44	9.70	26.27	28.29	31.68	39.58	42.60	39.93	33.53
Peak Gain (dBi)		-7.22	-5.54	-1.63	-1.29	-0.75	0.06	0.94	0.69	0.46
Return Loss (dB)		< -2	< -3	< -10	< -10	< -10	< -10	< -10	< -8	< -4
Average Gain (dBi)	With 15x9cm Ground	-1.72	-4.35	-1.73	-1.67	-1.54	-1.38	-1.33	-1.70	-1.60
Efficiency (%)		67.86	37.27	67.08	68.13	70.22	72.83	73.67	67.77	69.40
Peak Gain (dBi)		1.24	-1.28	1.99	1.98	1.86	2.48	2.79	2.79	3.25
Return Loss (dB)		< -5		< -8						

Average Gain (dBi)	On 30x30cm ground Metal Edge	-2.98	-2.87	-1.46	-1.43	-1.42	-1.26	-1.31	-1.81	-3.01
Efficiency (%)		50.73	52.04	71.38	71.90	72.16	74.96	74.01	66.35	50.02
Peak Gain (dBi)		0.74	0.65	3.47	3.51	3.56	3.03	3.56	3.62	2.69
Return Loss (dB)		< -5		< -8						
Average Gain (dBi)	On 30x30cm Ground Metal Center	-8.87	-6.76	-2.61	-2.63	-2.71	-2.80	-3.03	-3.47	-3.29
Efficiency (%)		13.53	21.31	54.89	54.63	53.54	52.53	49.87	45.22	46.93
Peak Gain (dBi)		-4.74	-1.92	1.96	1.89	2.00	3.01	2.26	1.79	2.58
Return Loss (dB)		< -2		< -3						
Radiation	Omni-directional									
Polarization	Linear									
Impedance	50 Ω									
Input Power	10W									
MECHANICAL										
Antenna length	72mm									
Antenna Diameter	10mm									
Casing	POM									
Connector	SMA(M)									
Weight	6g									
Recommended Torque for Mounting	0.9N·m									
Max. Torque for Mounting	1.176N·m									
ENVIRONMENTAL										
Operation Temperature	-40°C ~ + 85°C									
Storage Temperature	-40°C ~ + 85°C									
Humidity	Non-condensing 65°C 95% RH									

3. Antenna Characteristics

3.1 Testing setup

Antenna Straight Position

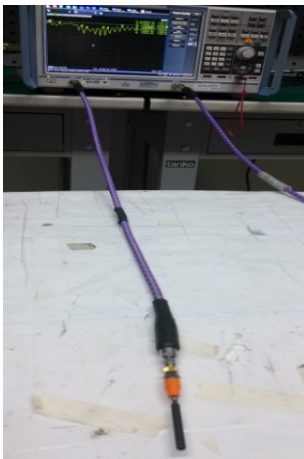

a) In free space

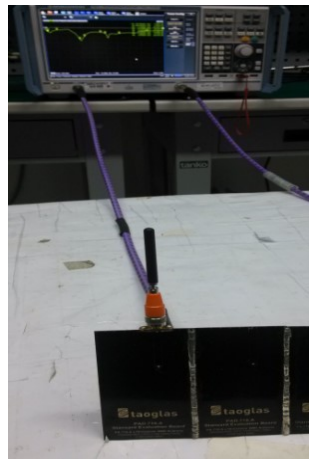

b) with 15*9cm Ground



c) with 30*30cm Ground Metal Edge

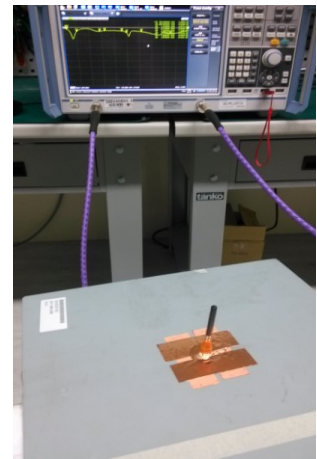

d) with 30*30cm Ground Metal Center

Antenna bent Position

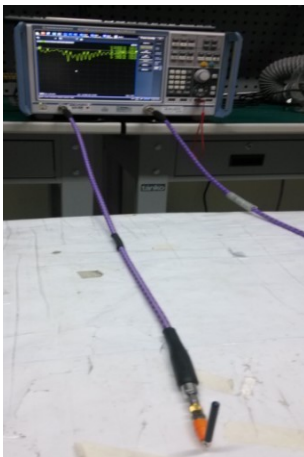

a) In free space



b) with 15*9cm Ground



c) with 30*30cm Ground Metal Edge

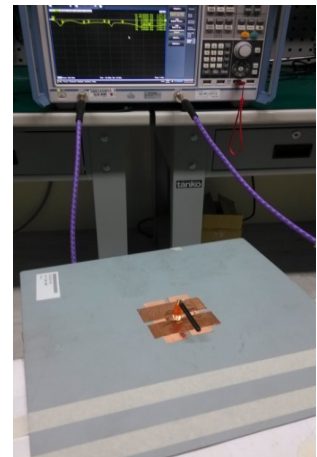

d) with 30*30cm Ground Metal Center

Figure.1 Measurement environments

3.2 Return loss

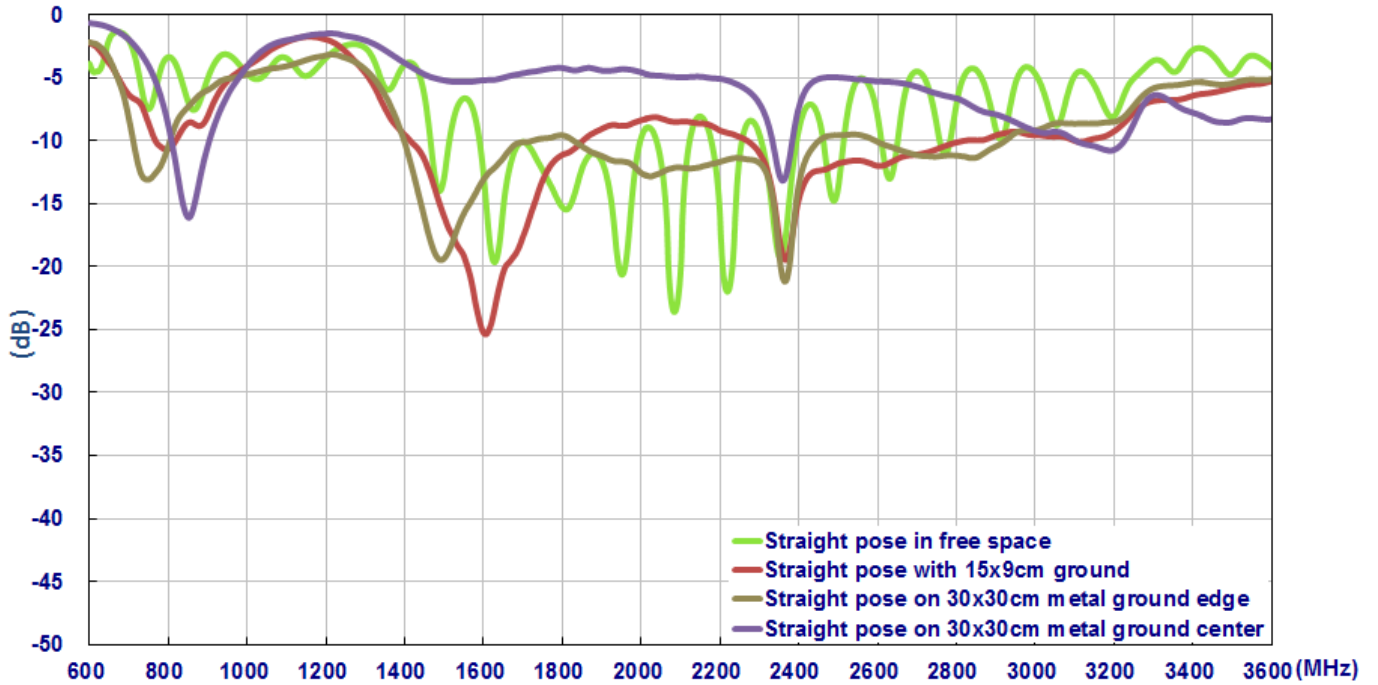

Figure2. Return loss of TG.08 antenna with straight Position

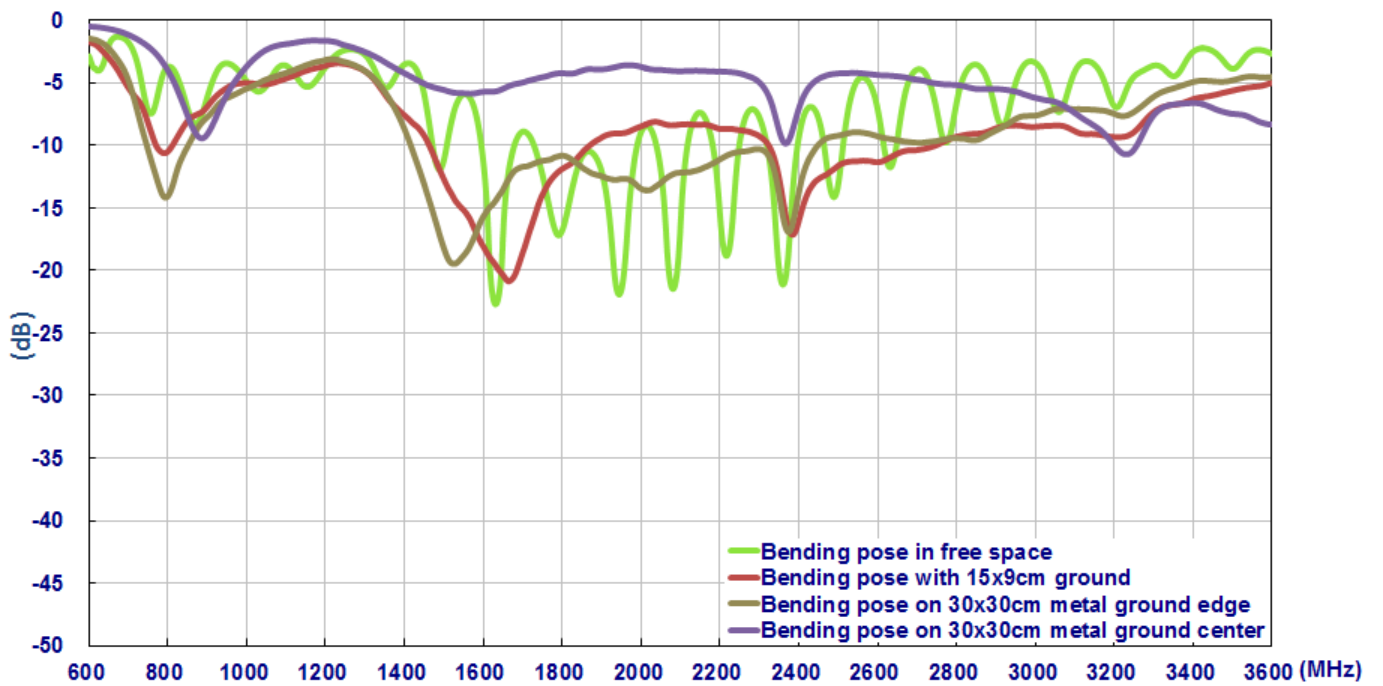

Figure3. Return loss of TG.08 antenna with bent Position

3.3 Efficiency

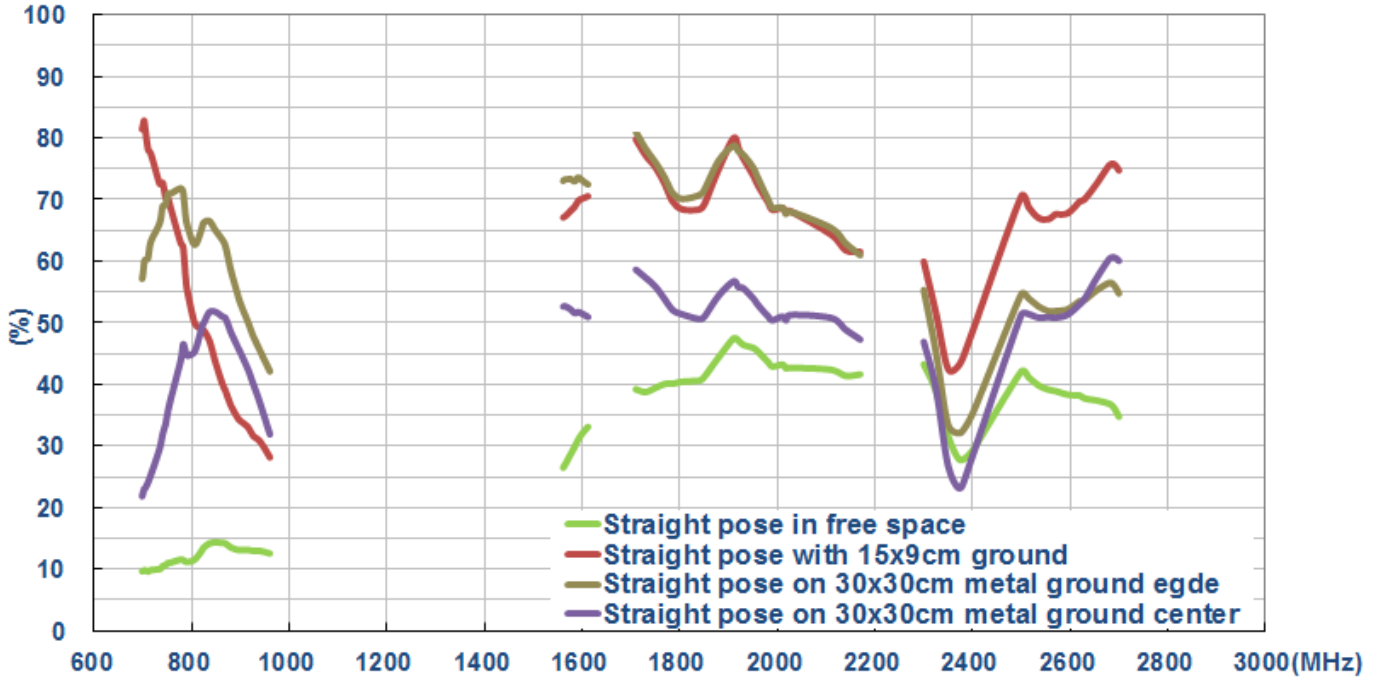

Figure4. Efficiency of TG.08 antenna with straight Position

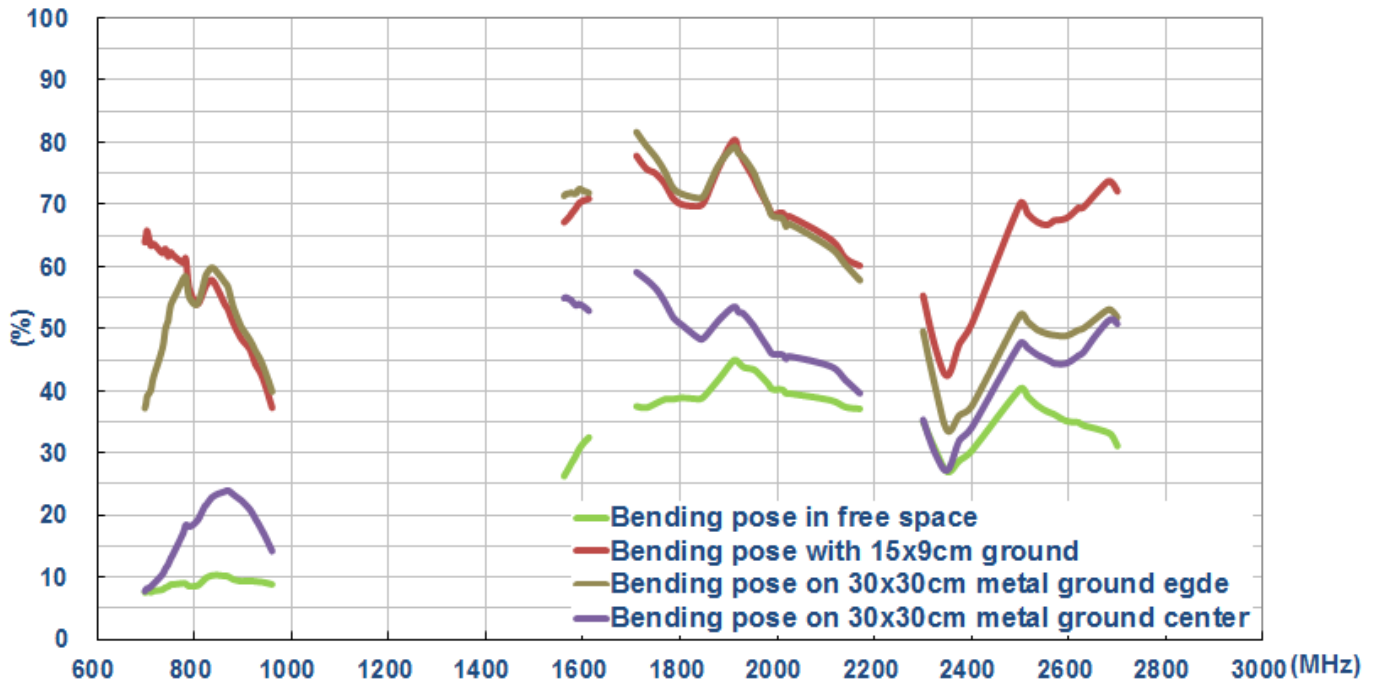

Figure5. Efficiency of TG.08 antenna with bent Position

3.4 Peak gain



Figure 6. Peak gain of TG.08 antenna with straight Position

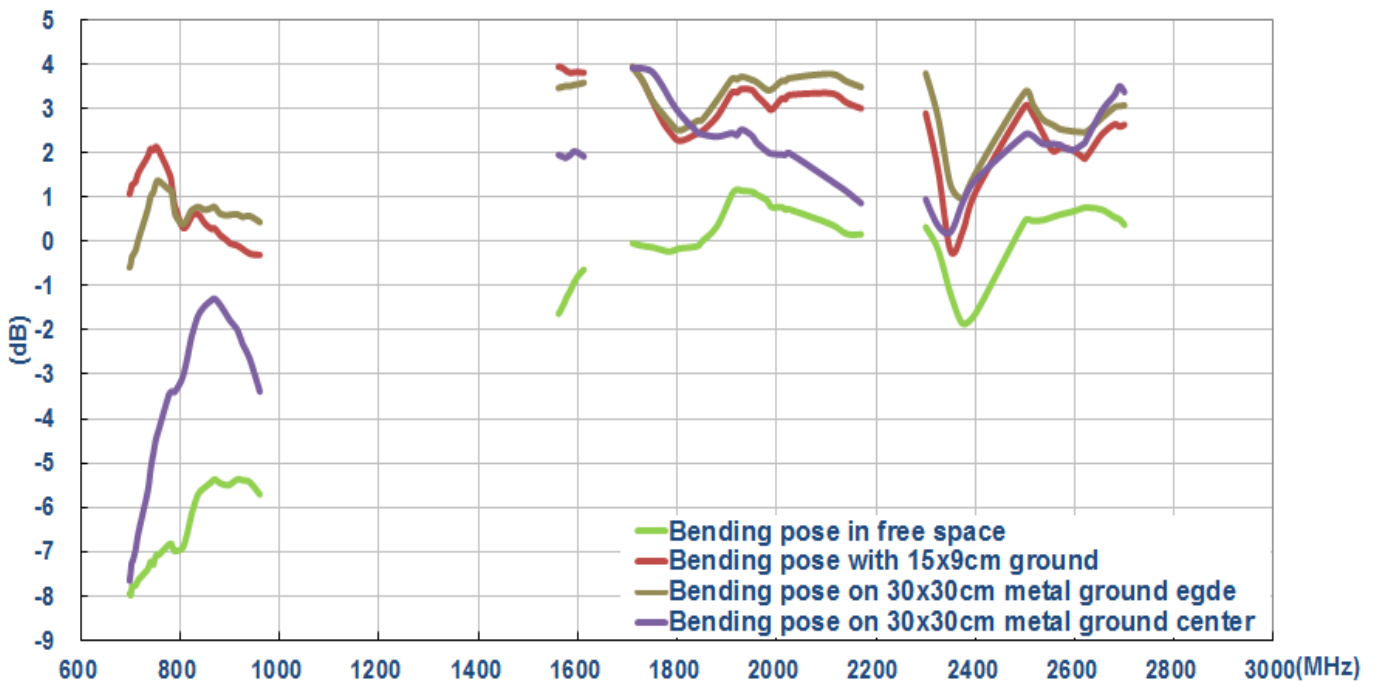

Figure 7. Peak gain of TG.08 antenna with bent Position

3.5 Average gain

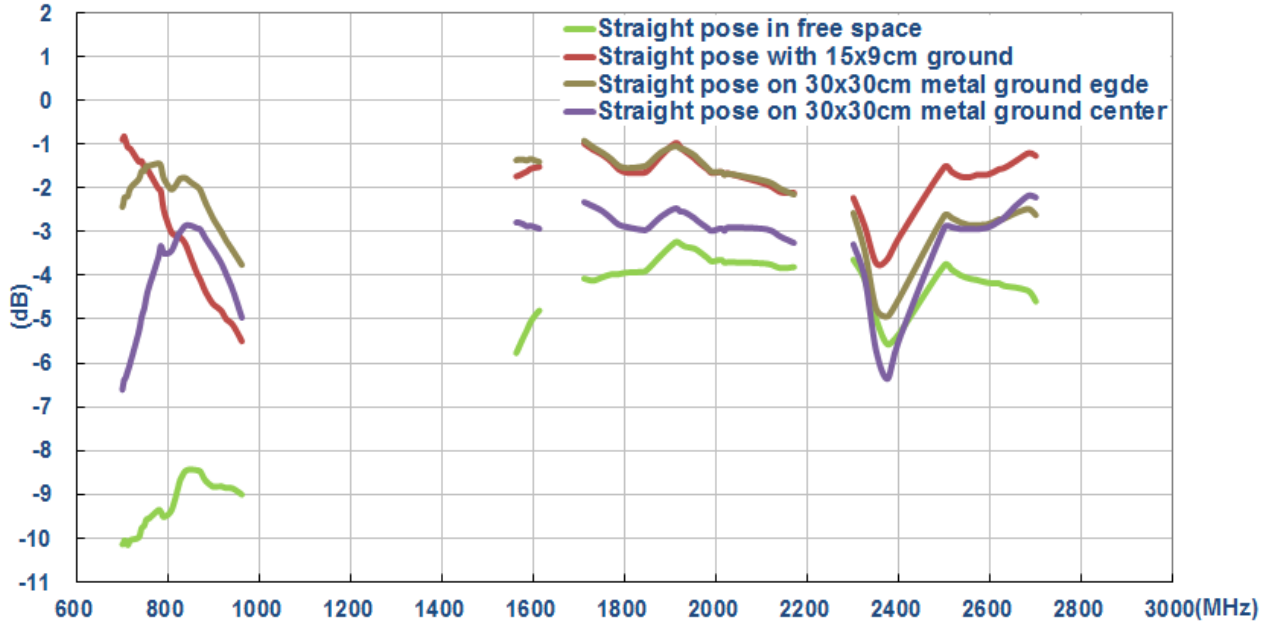

Figure8. Average gain of TG.08 with antenna straight Position

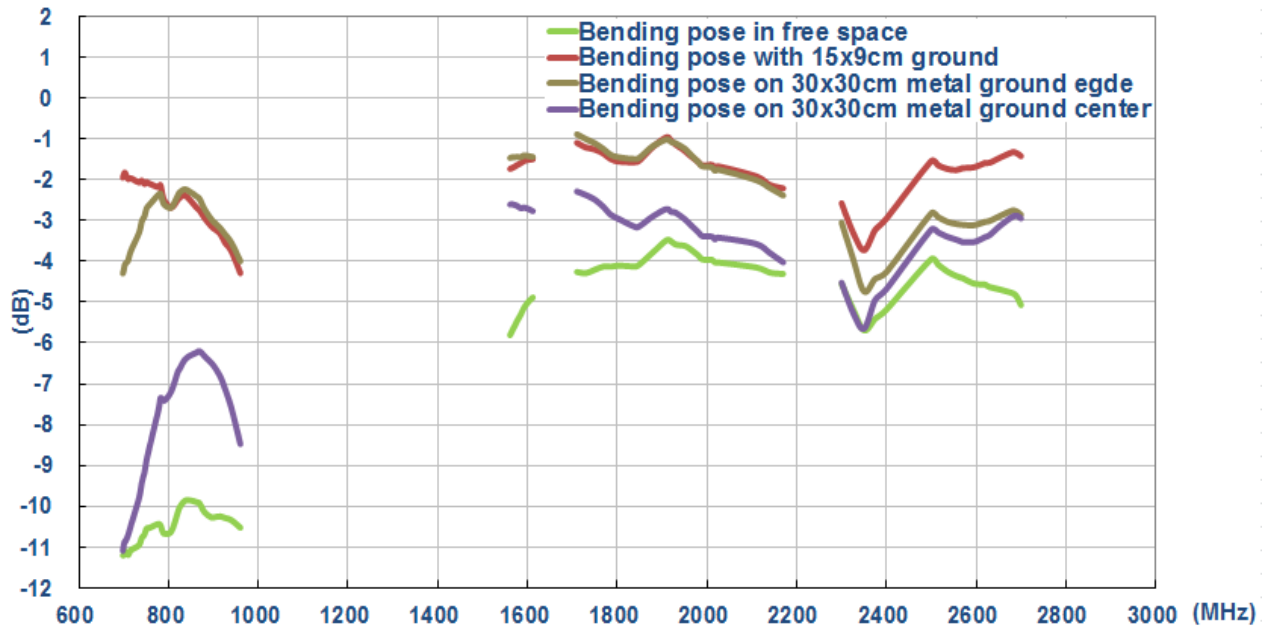
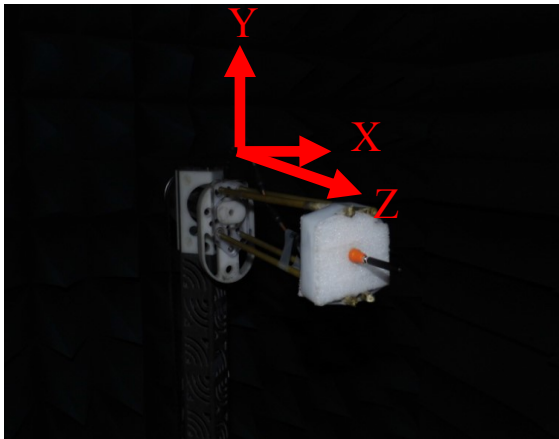

Figure9. Average gain of TG.08 antenna with bent Position

4. Antenna Radiation Patterns

The antenna radiation patterns were measured in a CTIA certified ETS Anechoic Chamber. The measurement setups are shown below.

Antenna with Straight Position



In free space

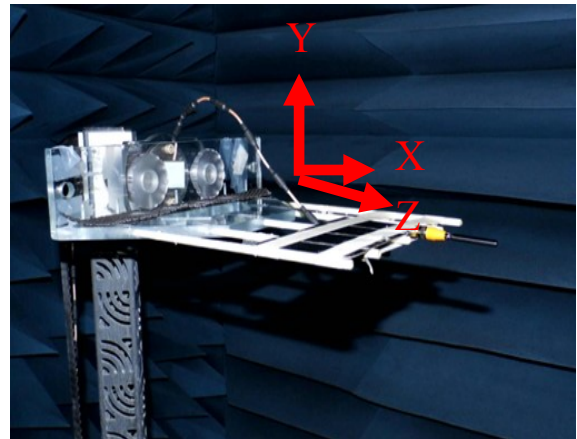

On 15x9cm ground plane

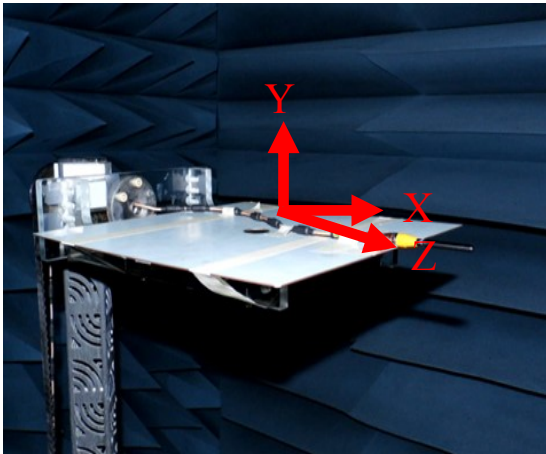

On 30x30cm metal ground center

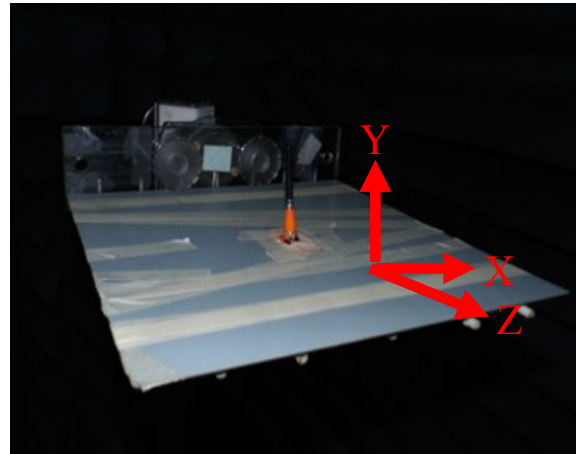

On 30x30cm metal ground edge

Antenna Bent Position

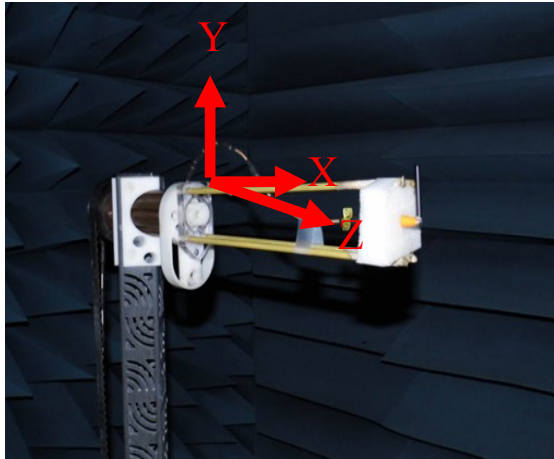

In free space

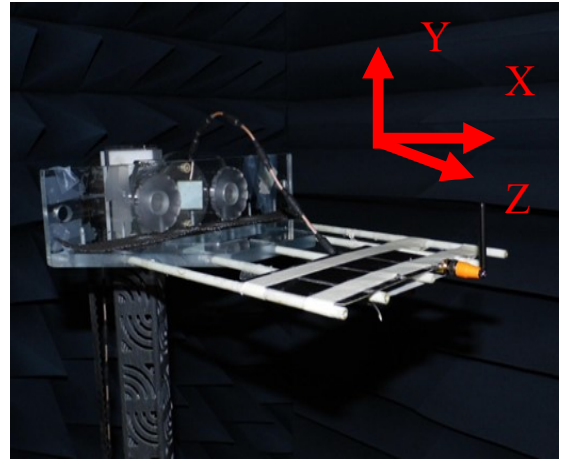

On 15x9cm ground plane

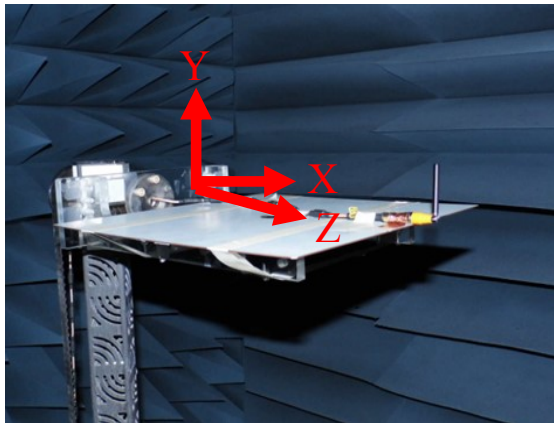

On 30x30cm metal ground edge

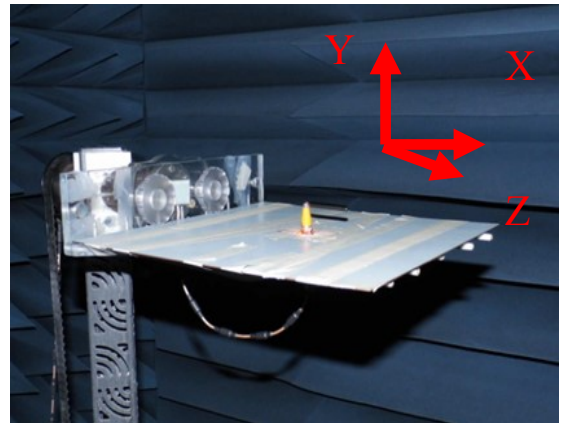

On 30x30cm metal ground center

Figure.10. Testing Setup in ETS Anechoic Chamber

4.1 2D Radiation pattern (Straight Position in free space)

XY Plane

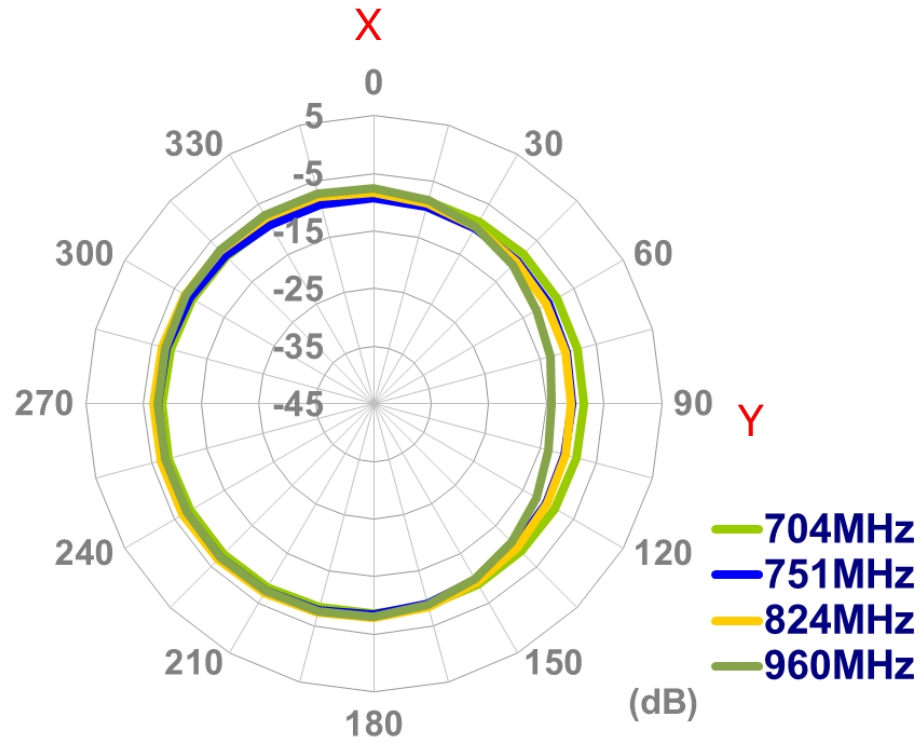

XY Plane

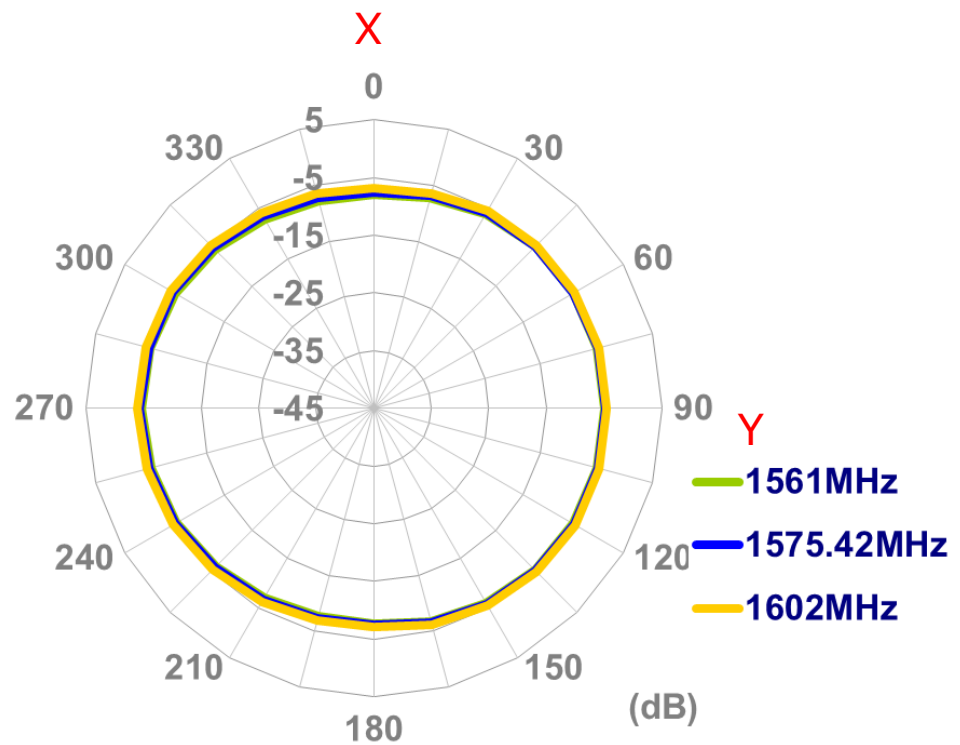

XY Plane

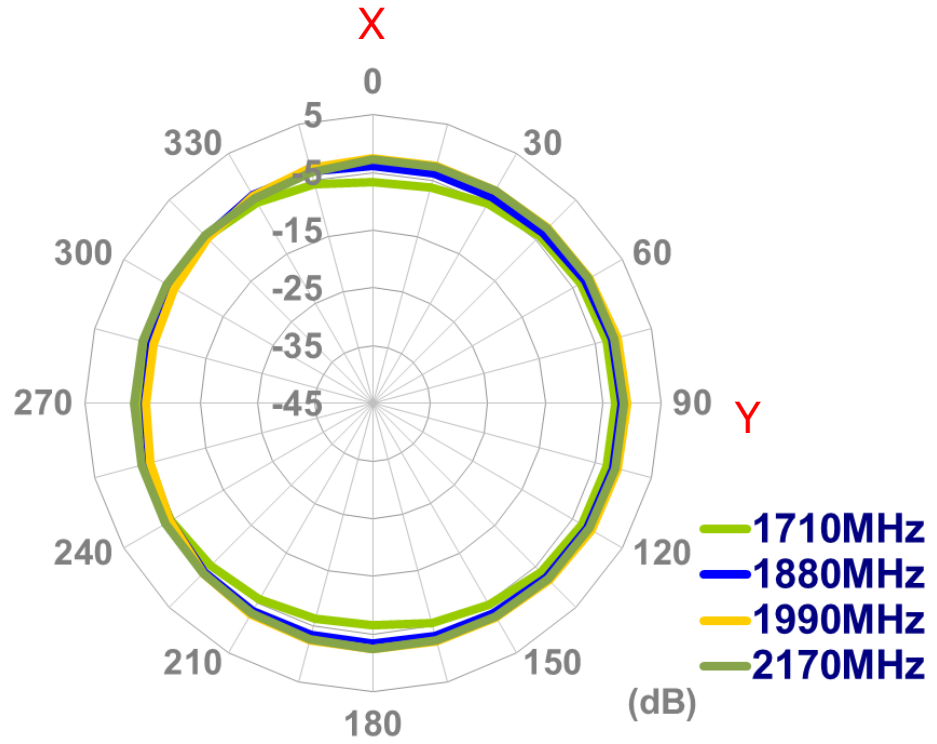

XY Plane

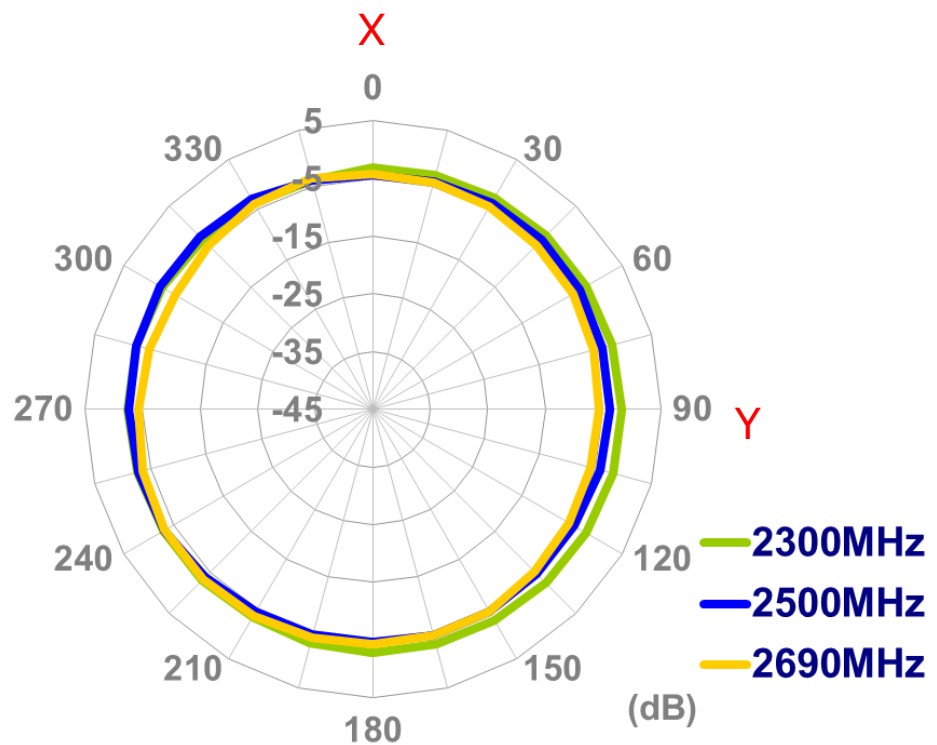

XZ Plane

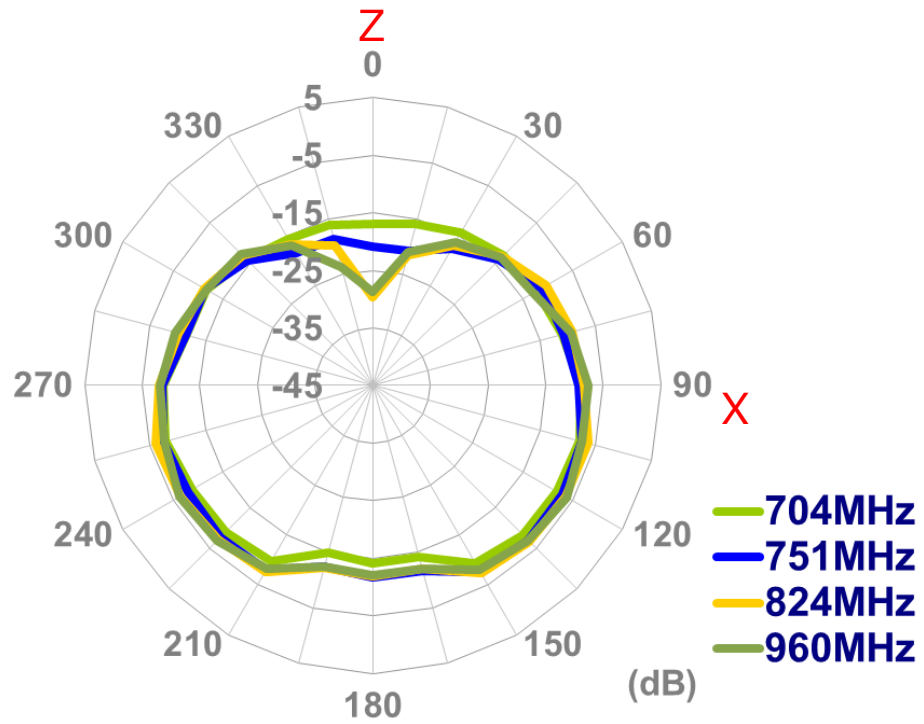

XZ Plane

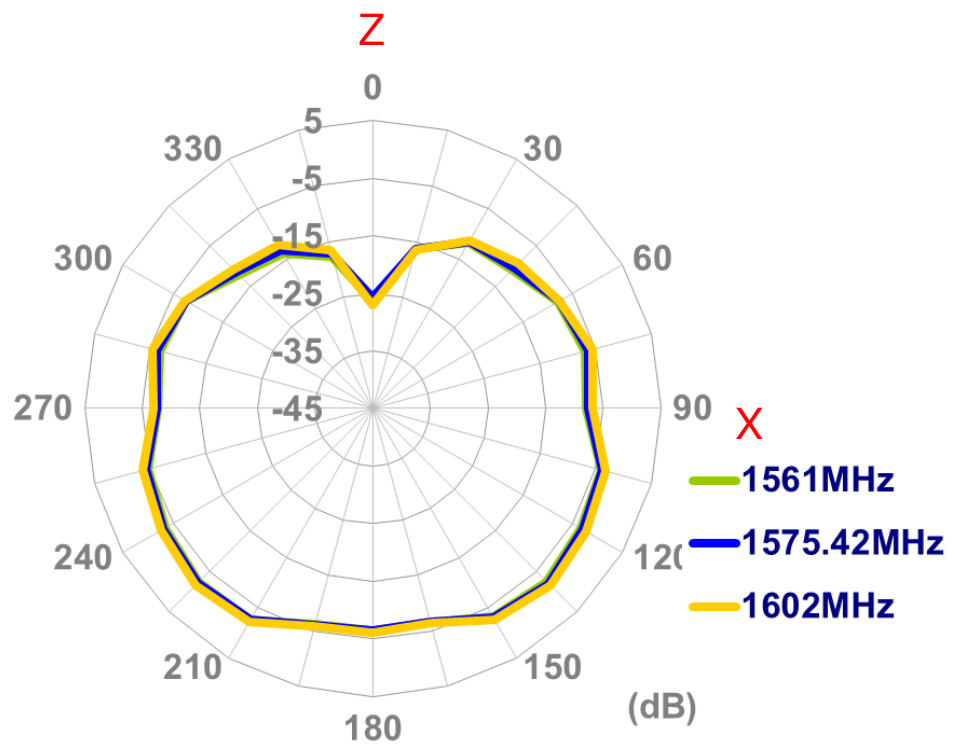

XZ Plane

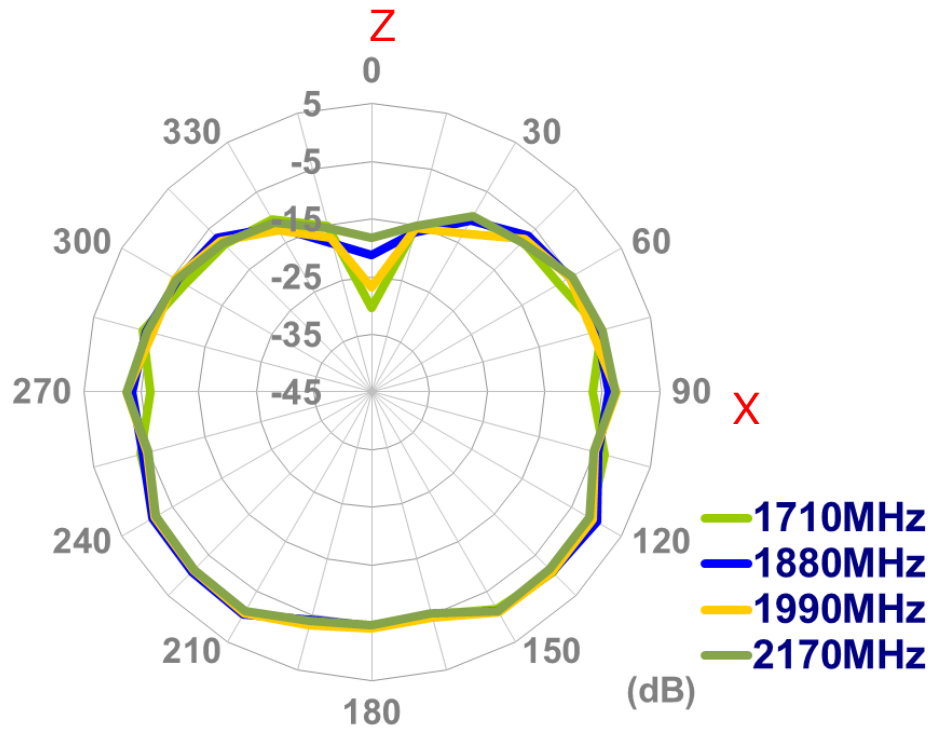

XZ Plane

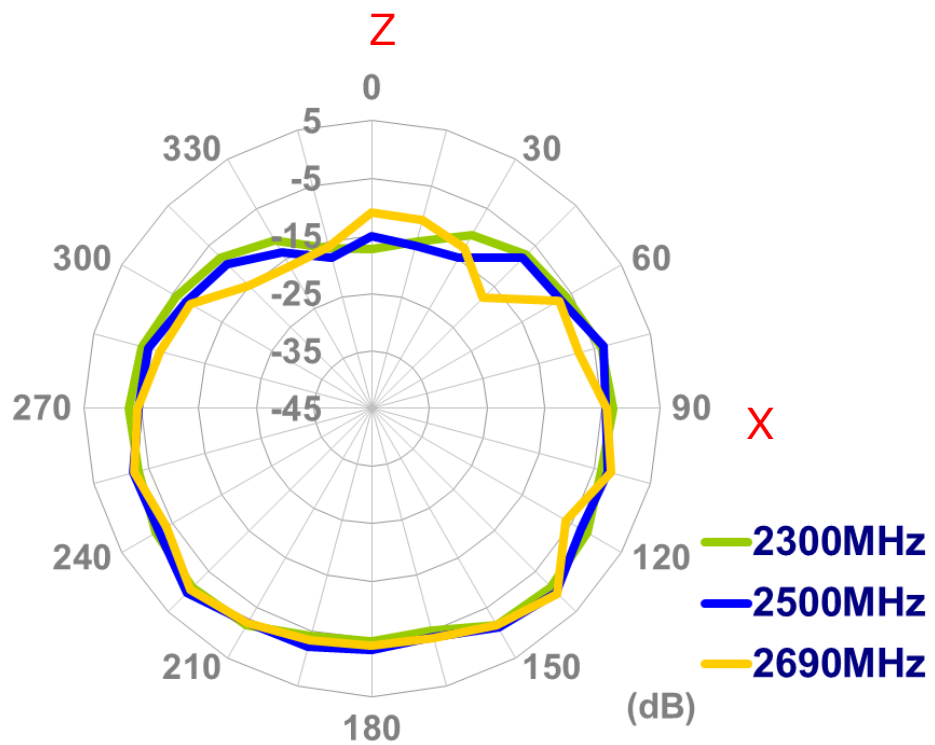

YZ Plane

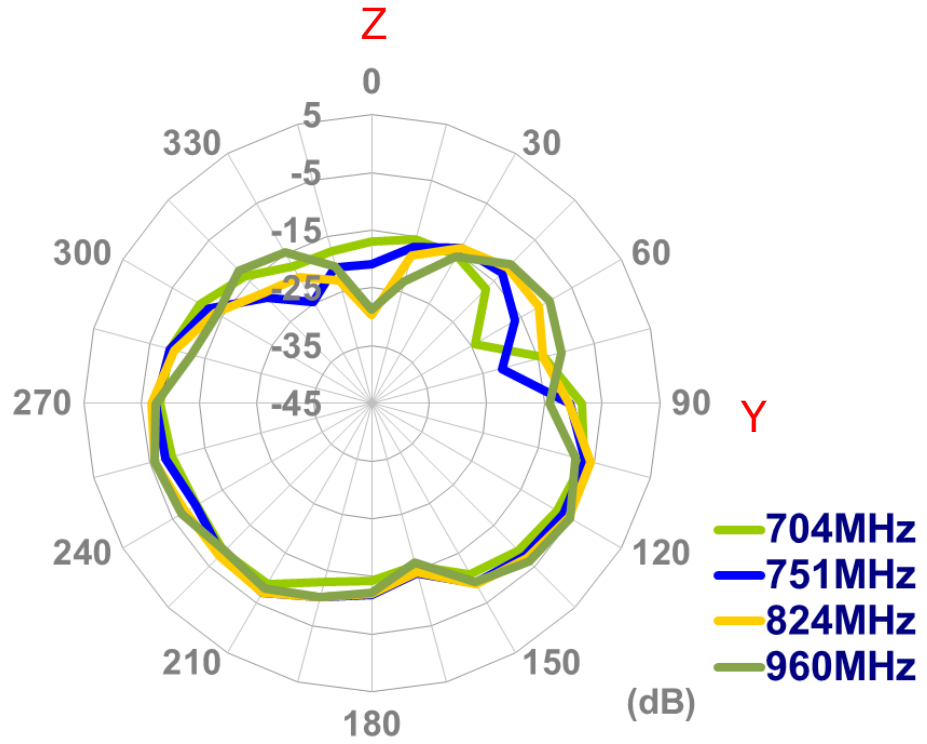

YZ Plane

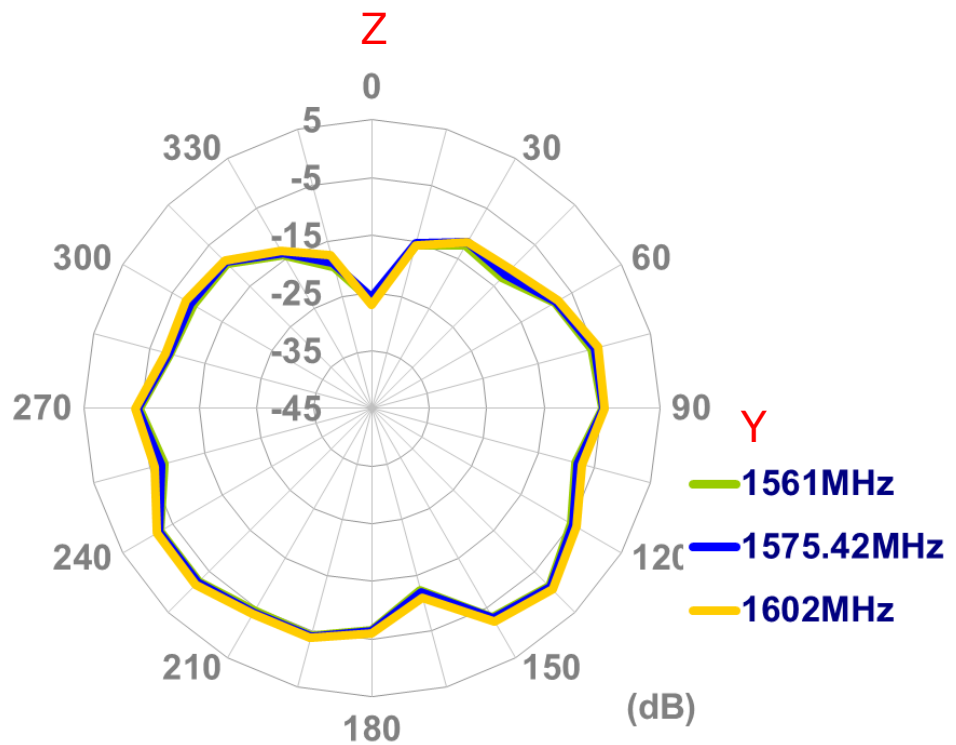

YZ Plane

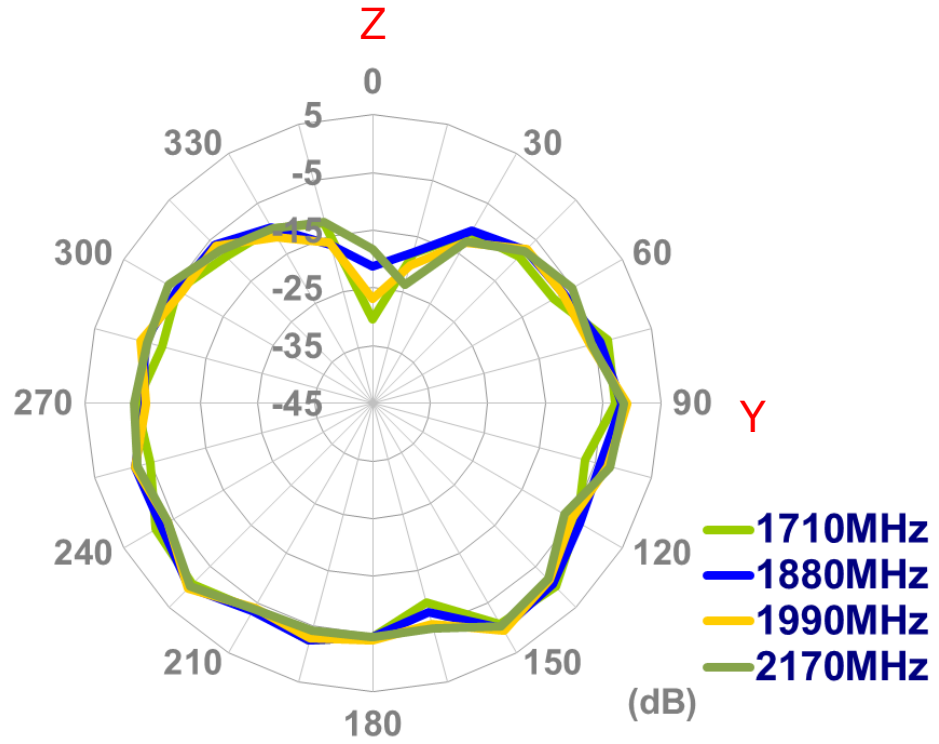

YZ Plane

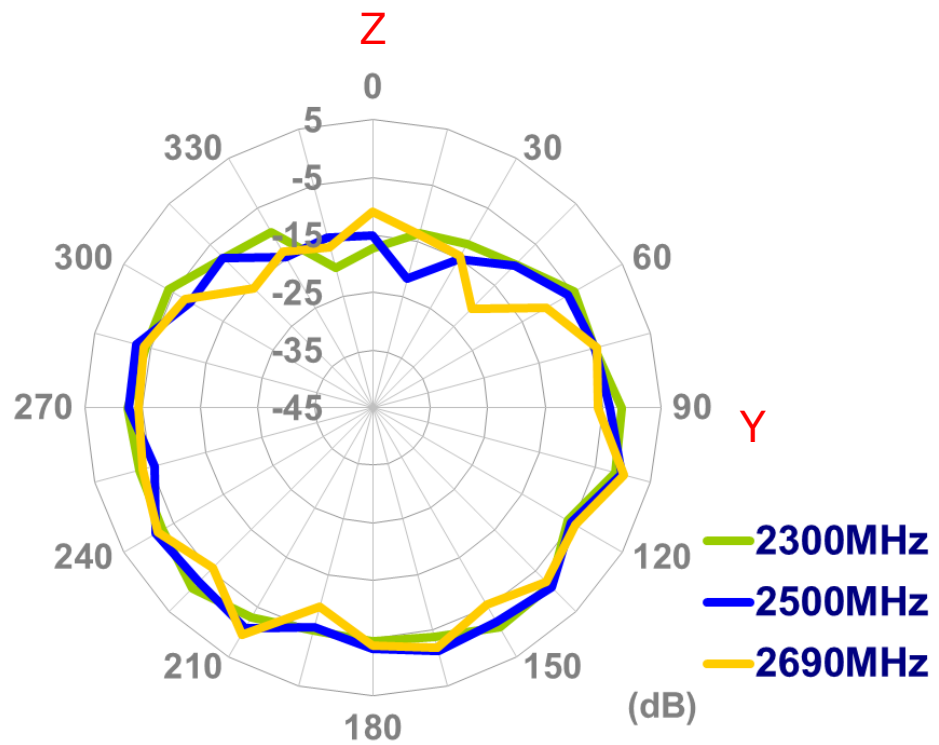

4.2 2D Radiation pattern (Straight Position with 15x9cm ground)

XY Plane

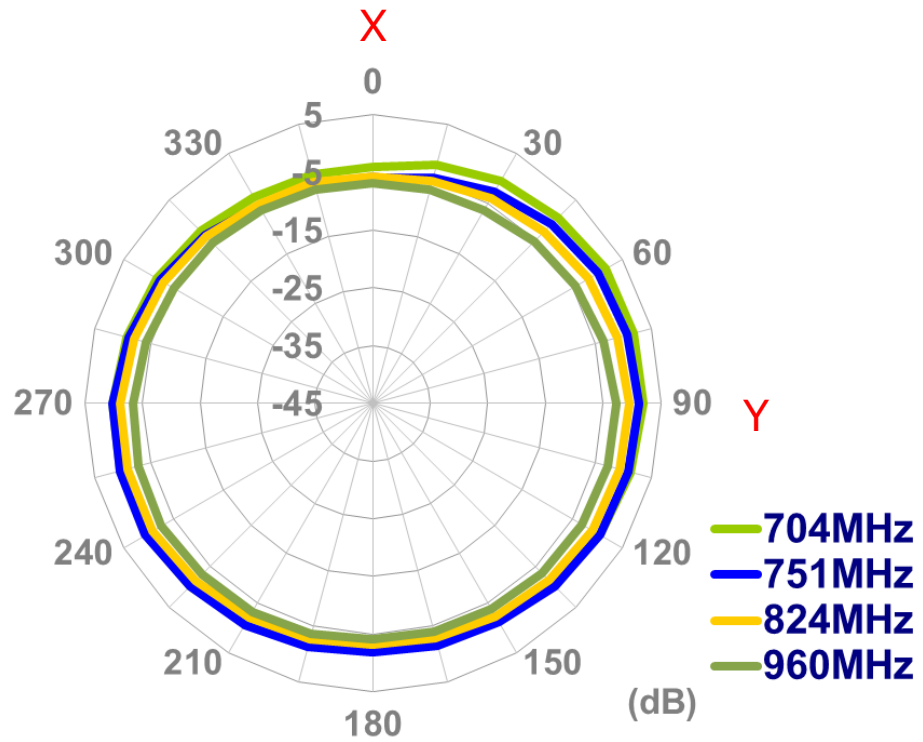

XY Plane

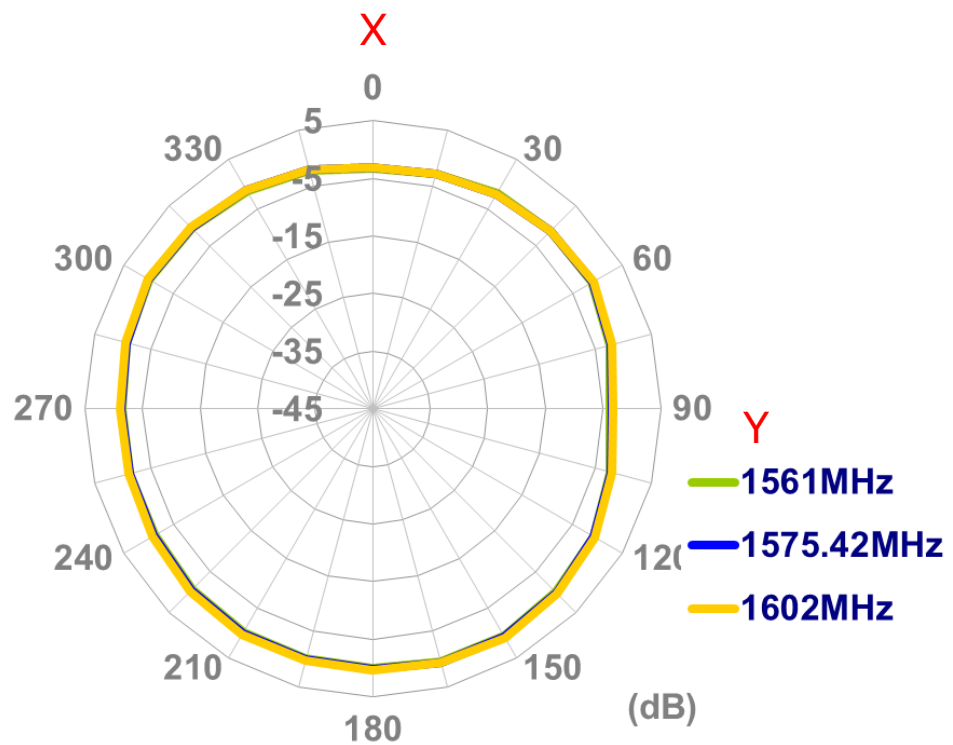

XY Plane

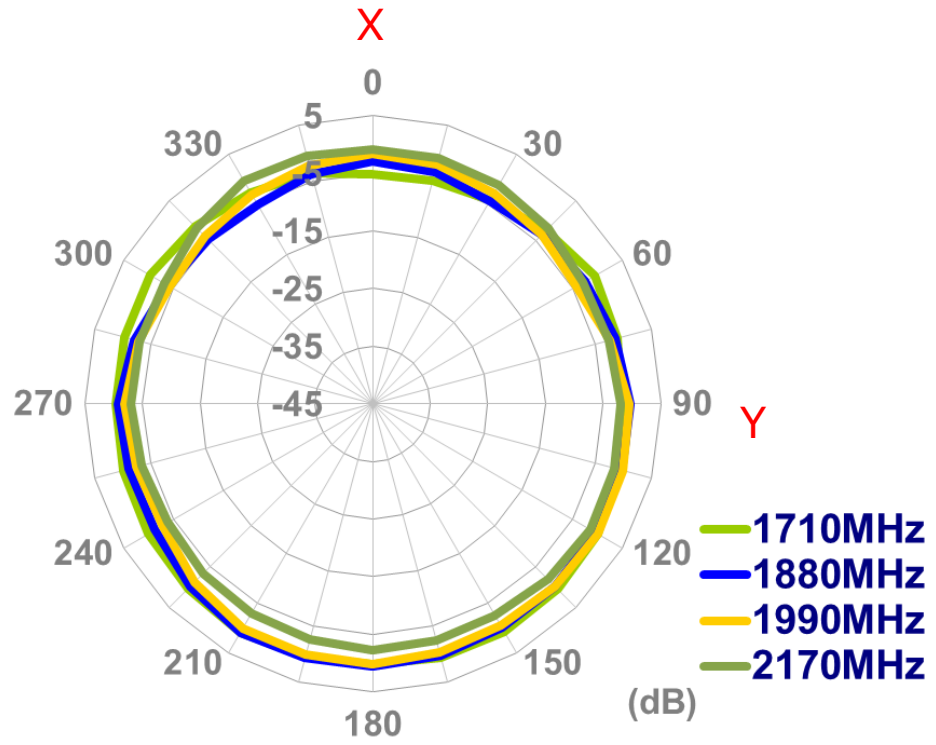

XY Plane

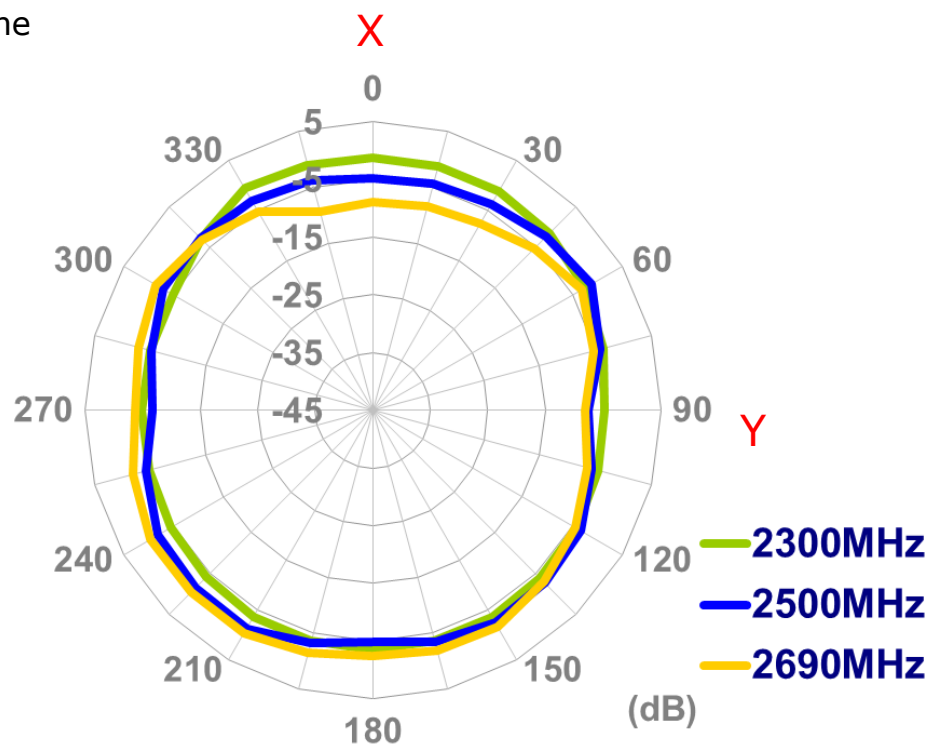

XZ Plane

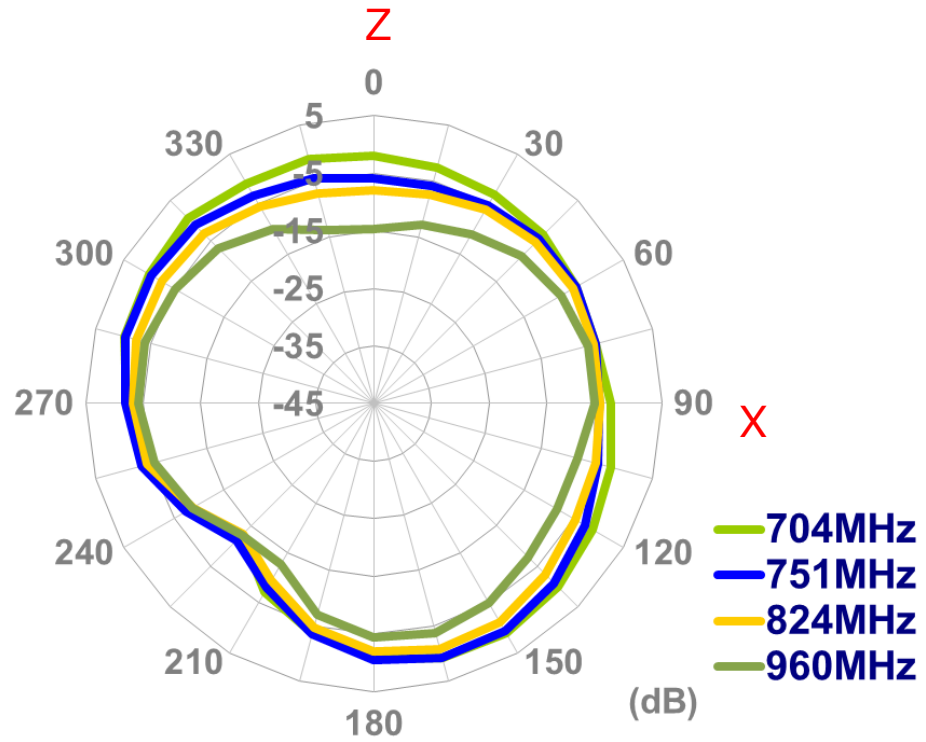

XZ Plane

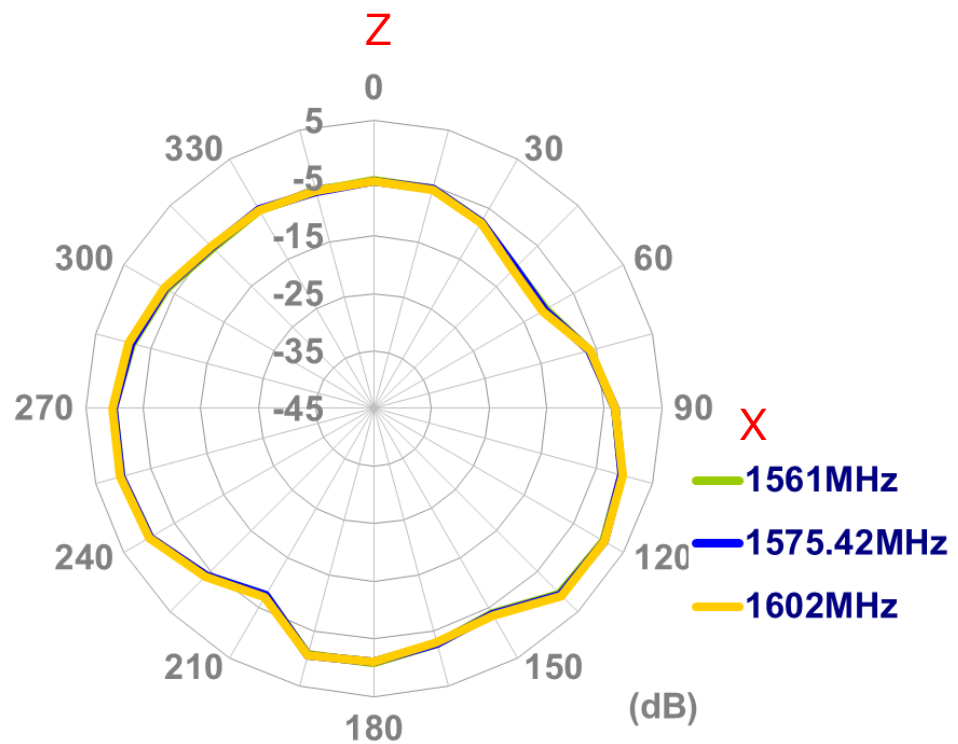

XZ Plane

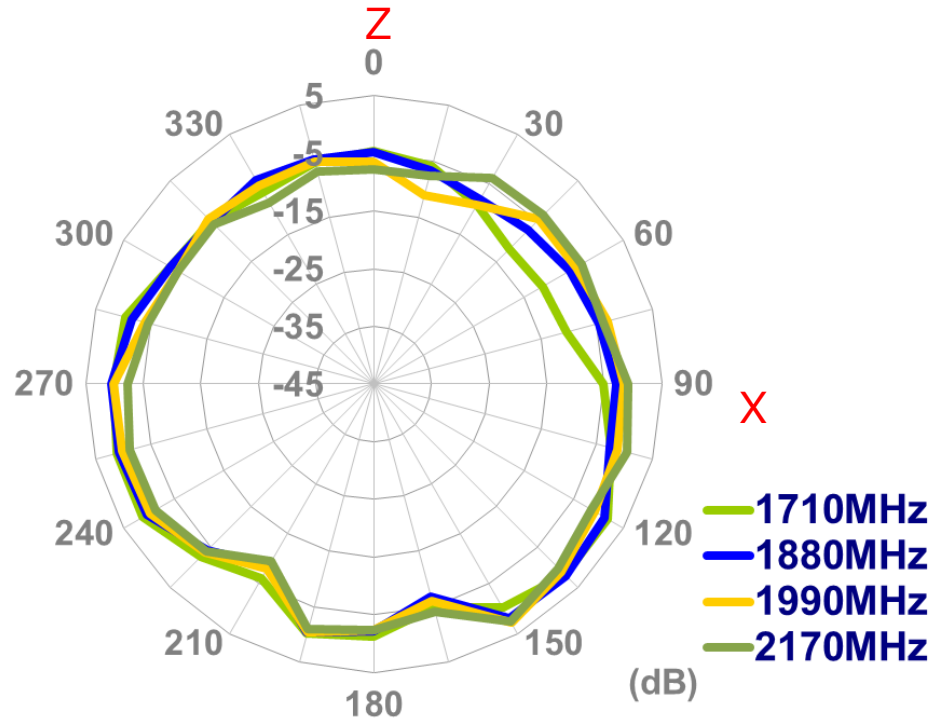

XZ Plane

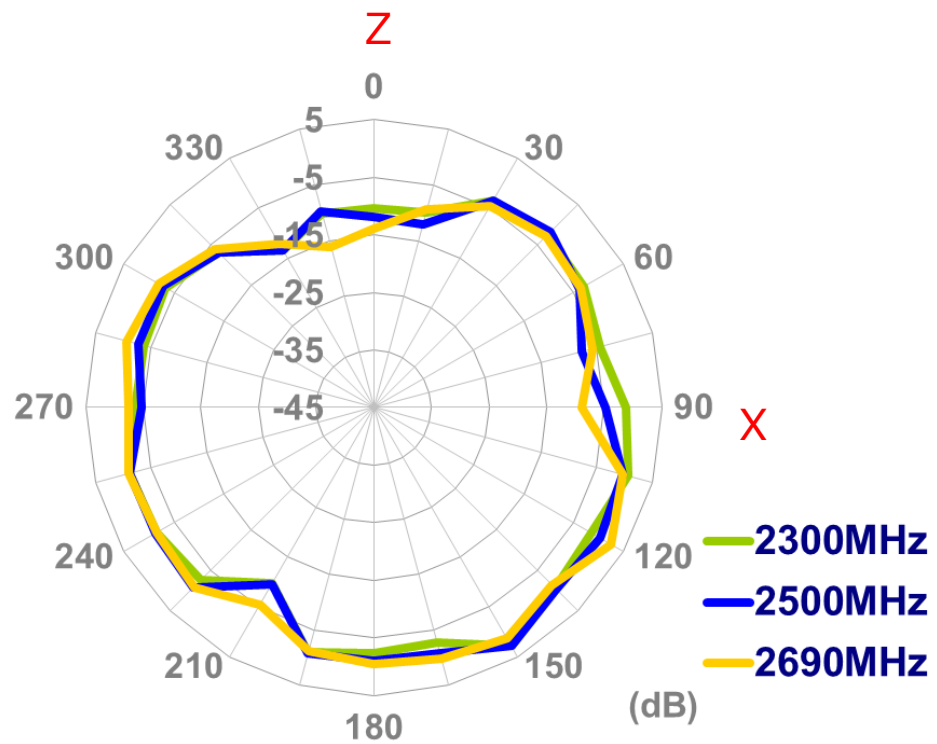

YZ Plane

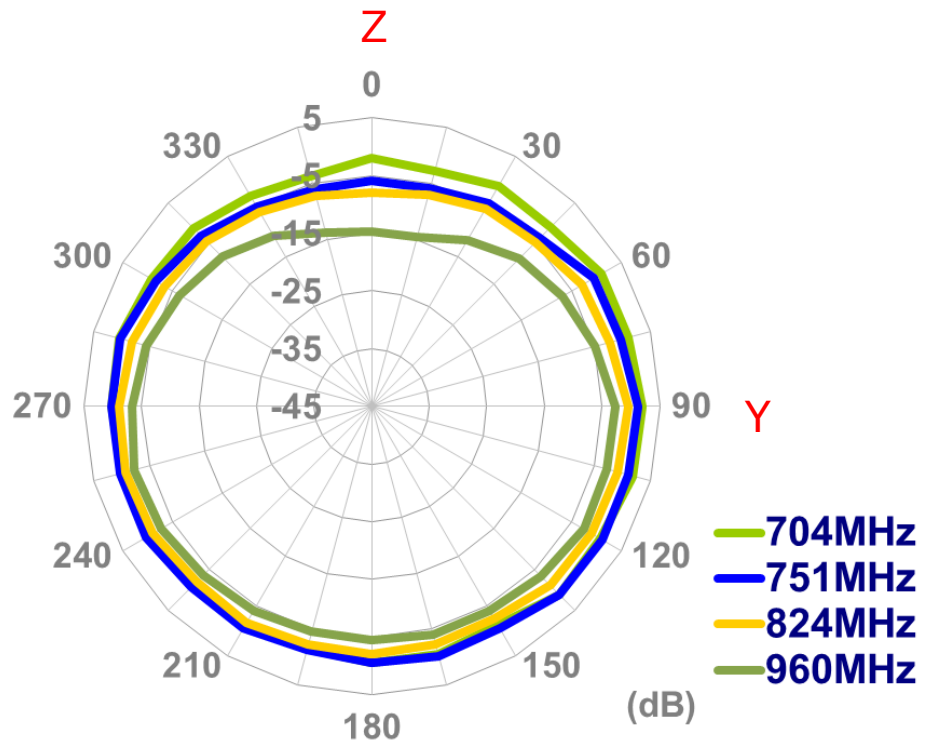

YZ Plane

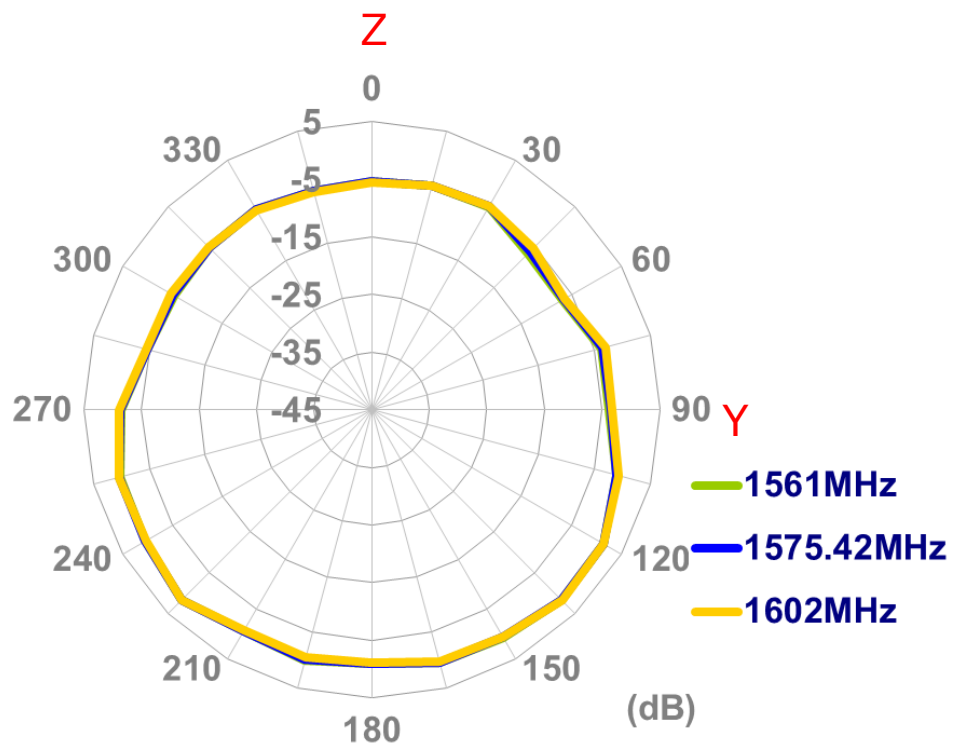

YZ Plane

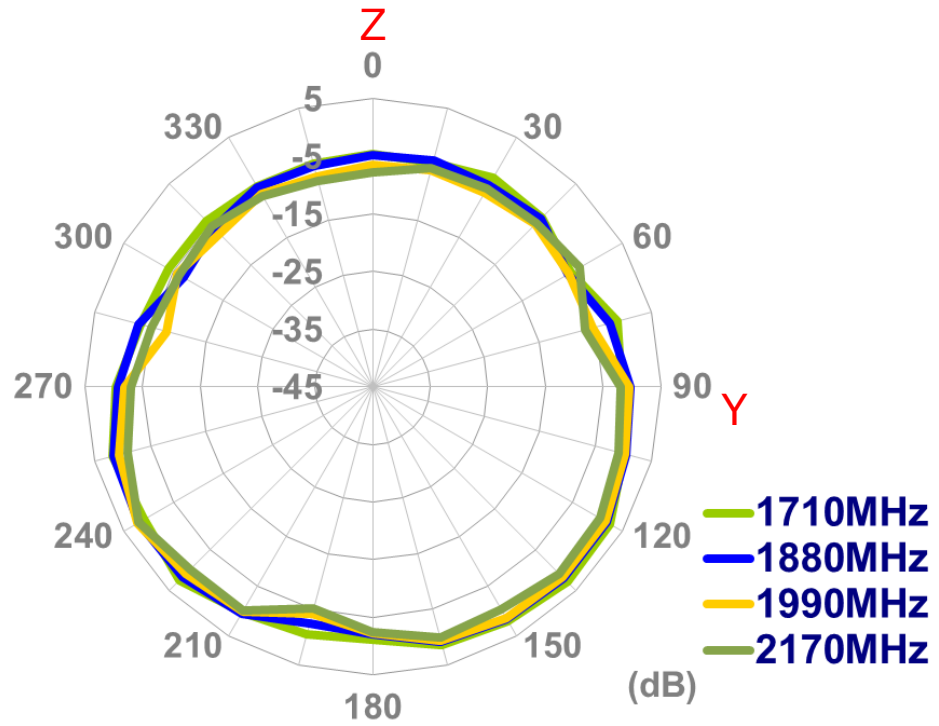

YZ Plane

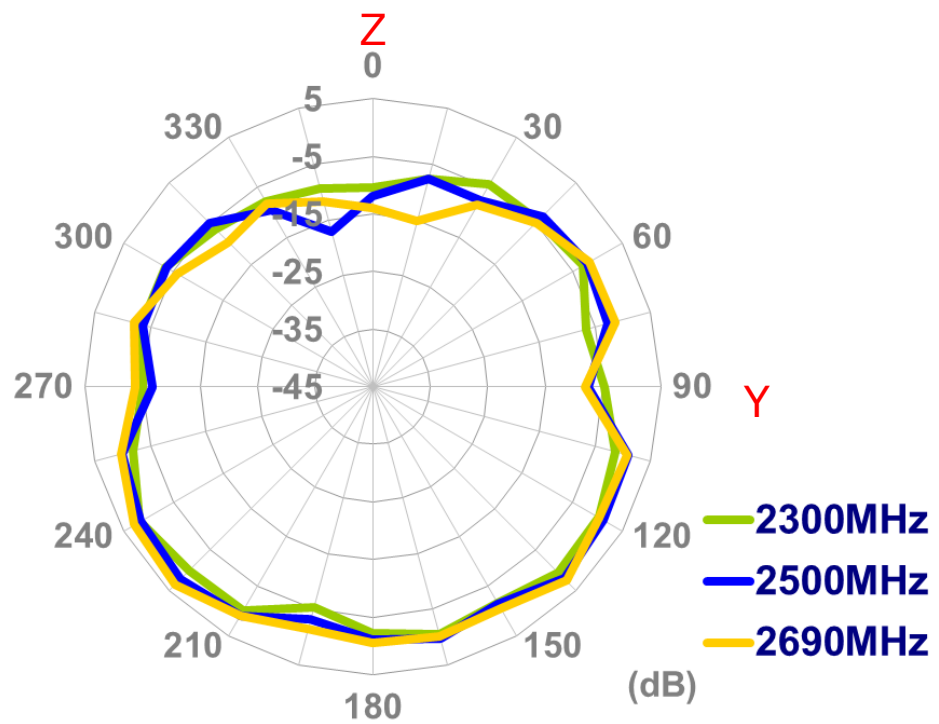

4.3 2D Radiation pattern (Straight Position with 30x30cm metal ground edge)

XY Plane

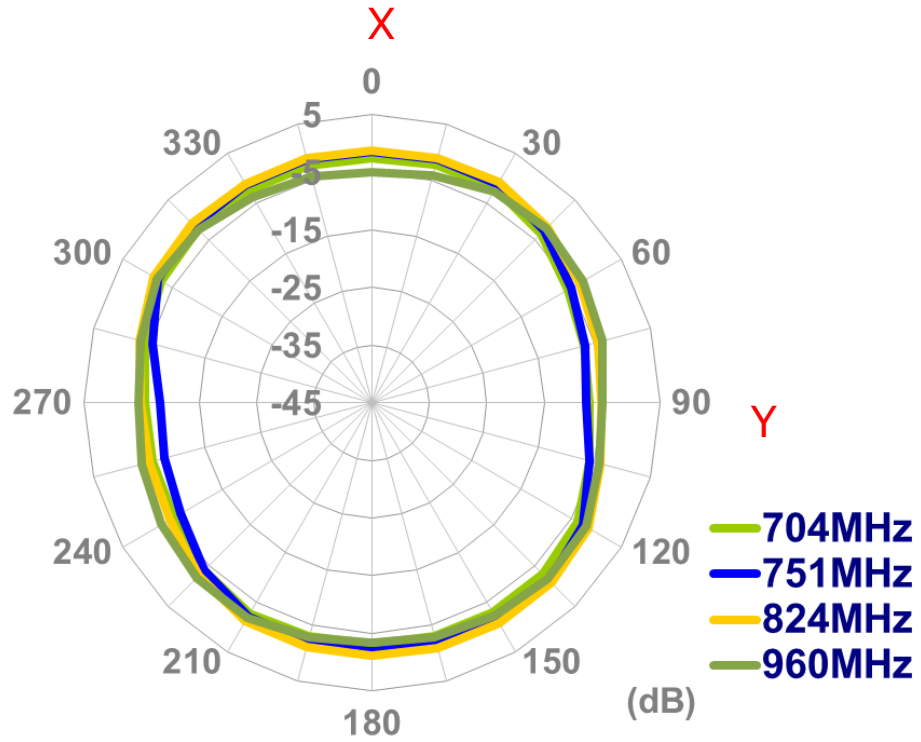

XY Plane

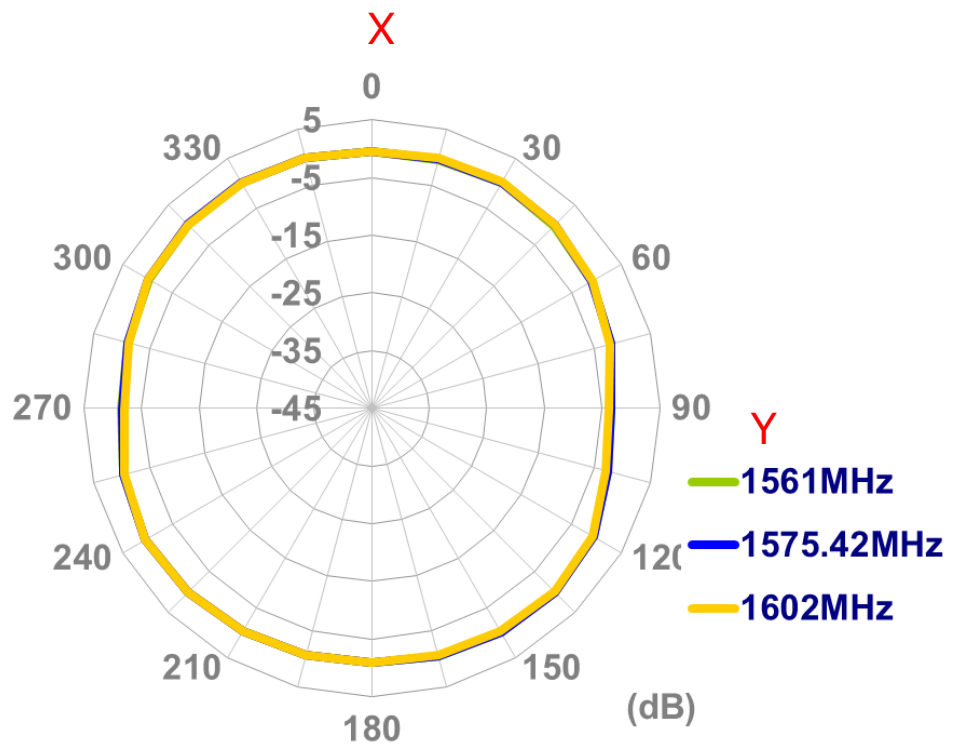

XY Plane

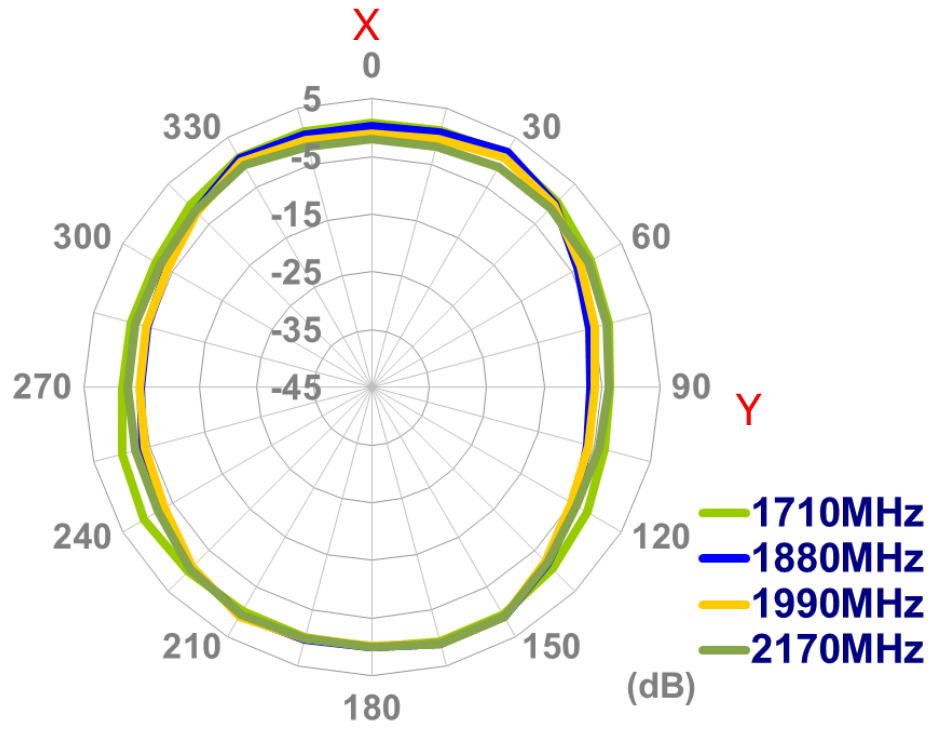

XY Plane

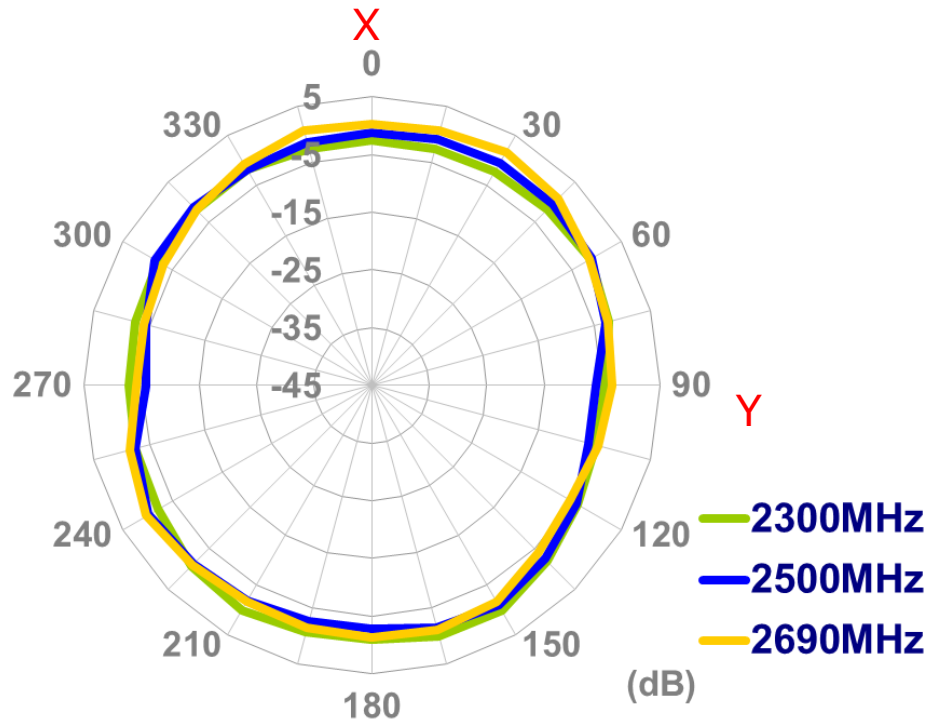

XZ Plane

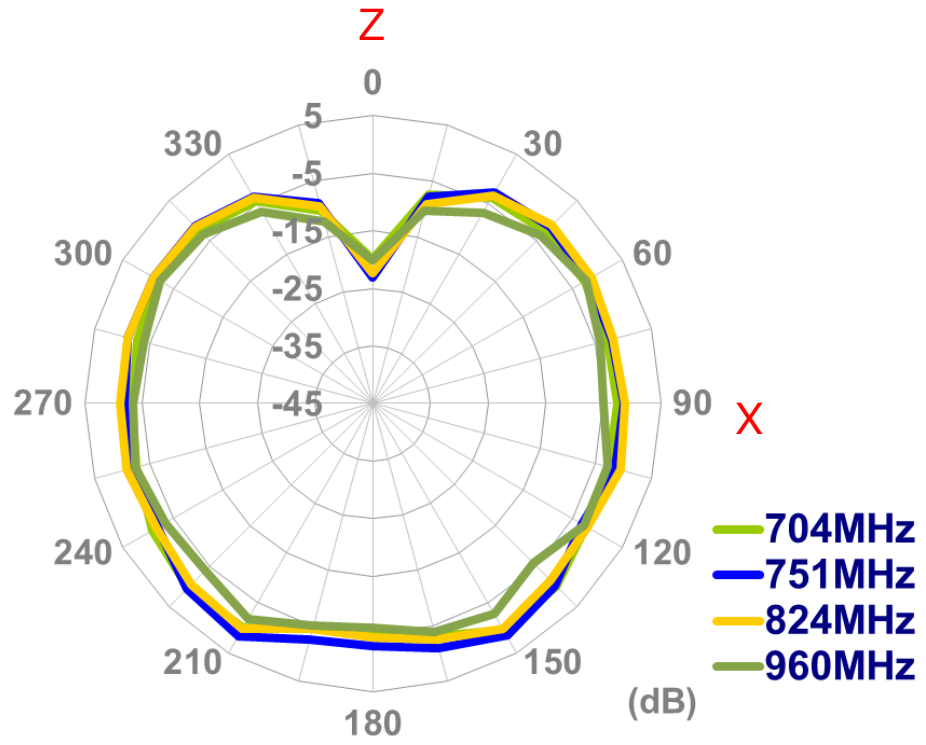

XZ Plane

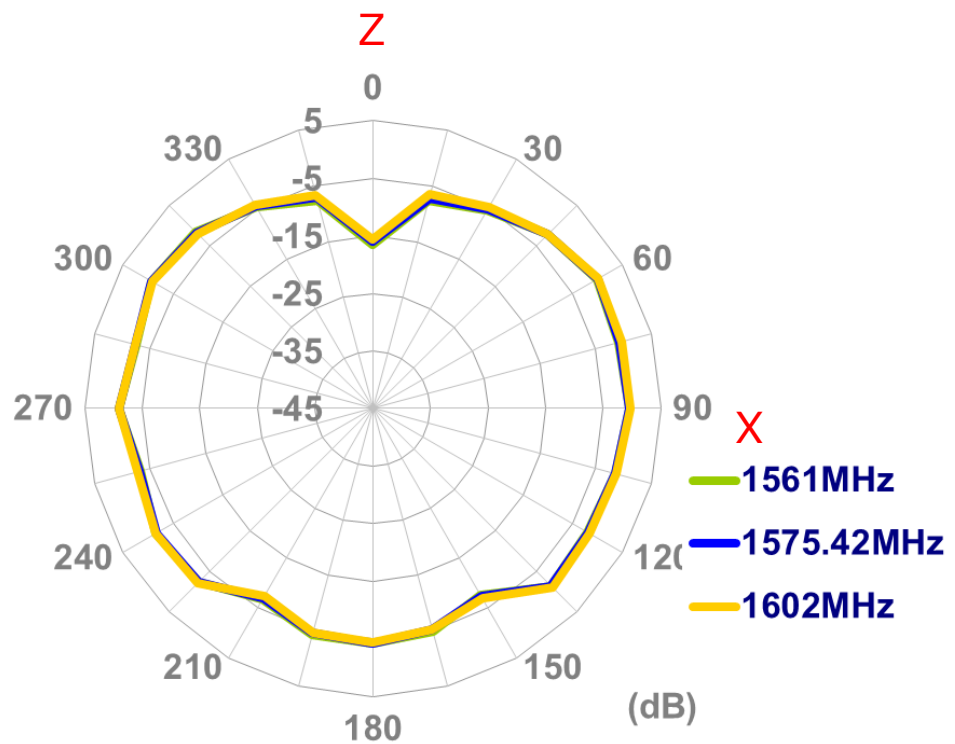

XZ Plane

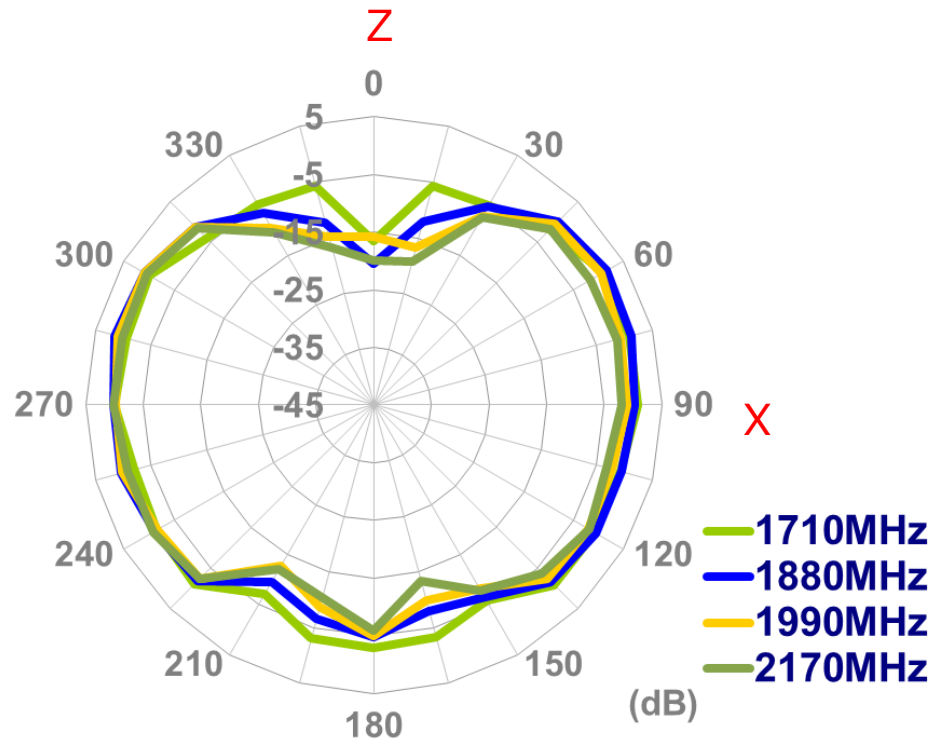

XZ Plane

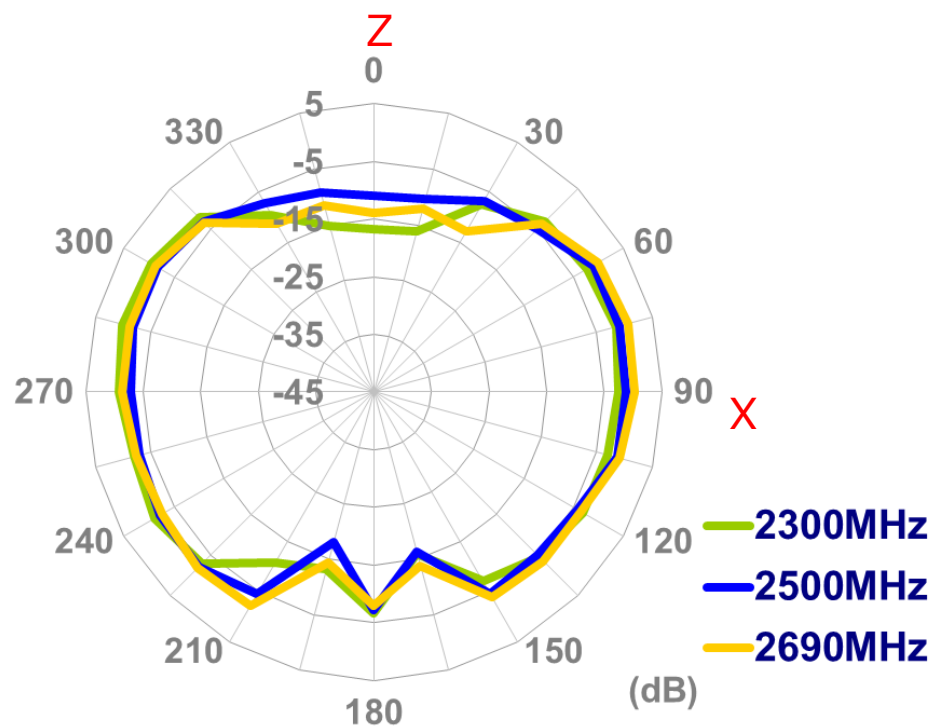

YZ Plane

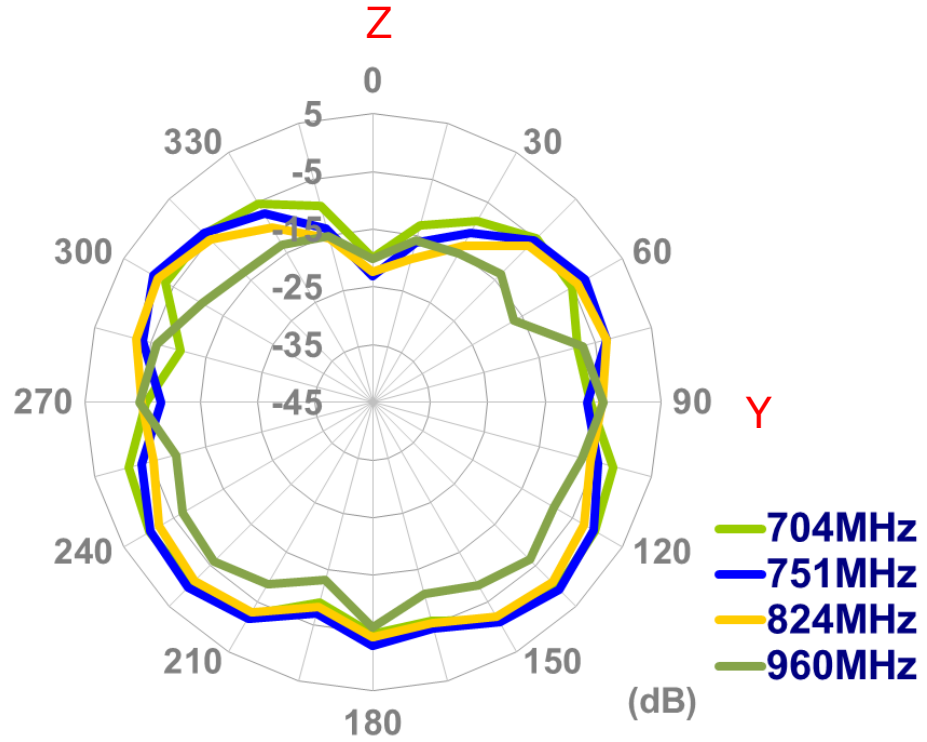

YZ Plane

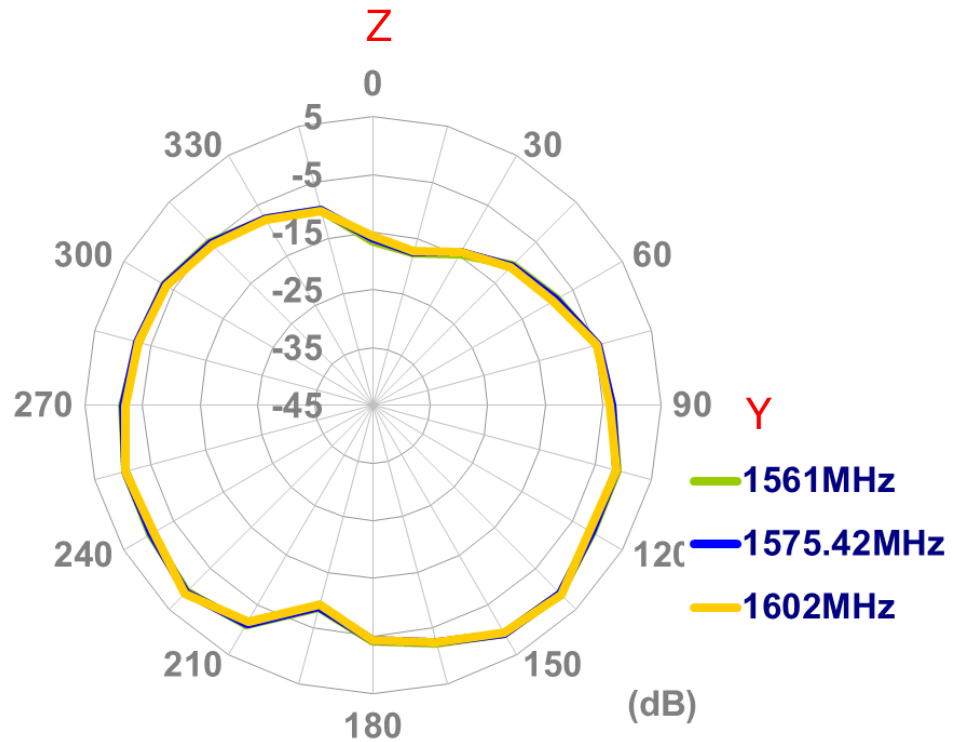

YZ Plane

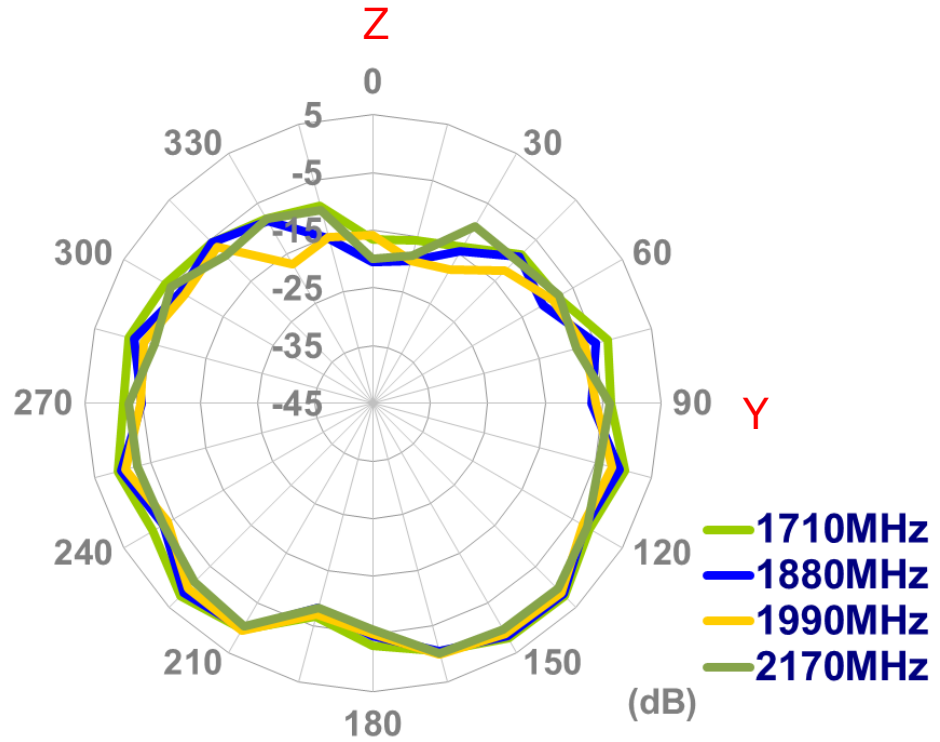

YZ Plane

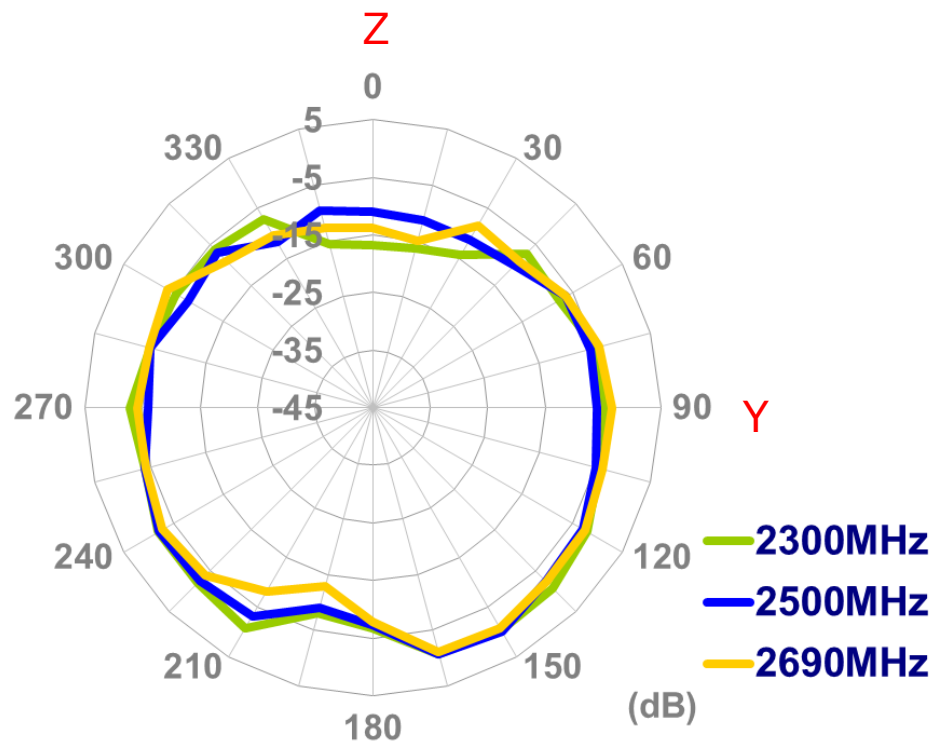

4.4 2D Radiation pattern (Straight Position with 30x30cm metal ground center)

XY Plane

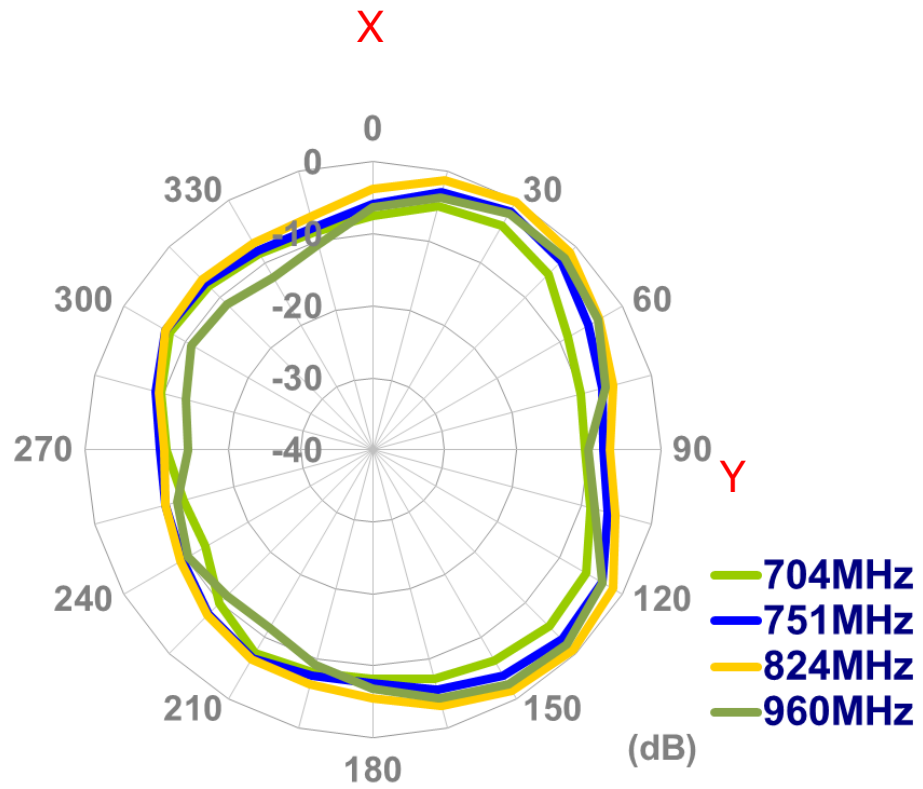

XY Plane

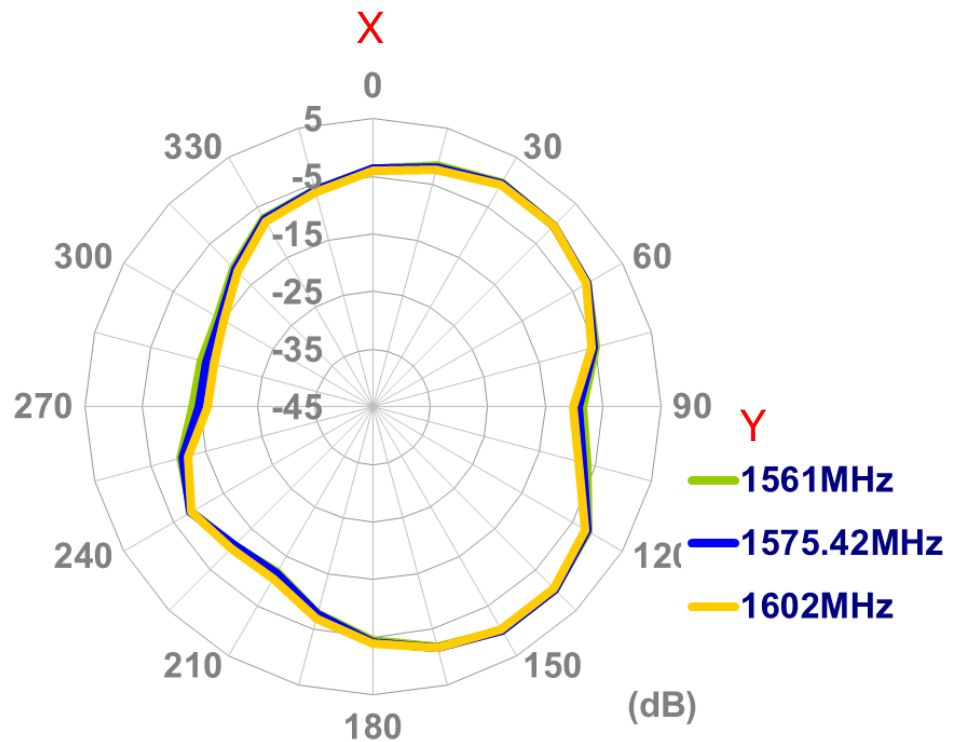

XY Plane

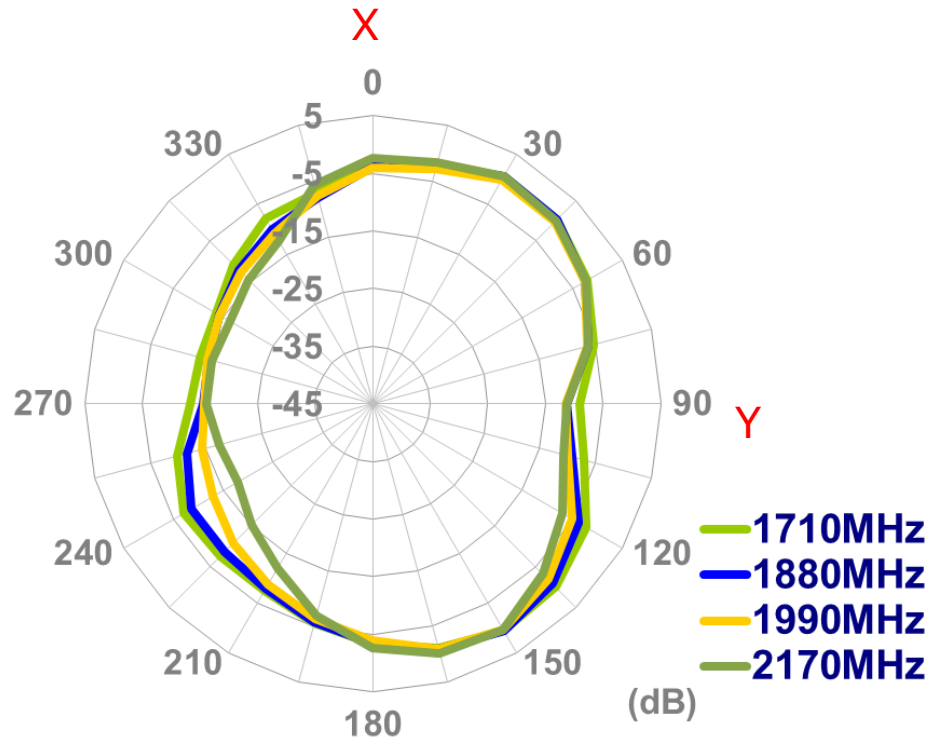

XY Plane

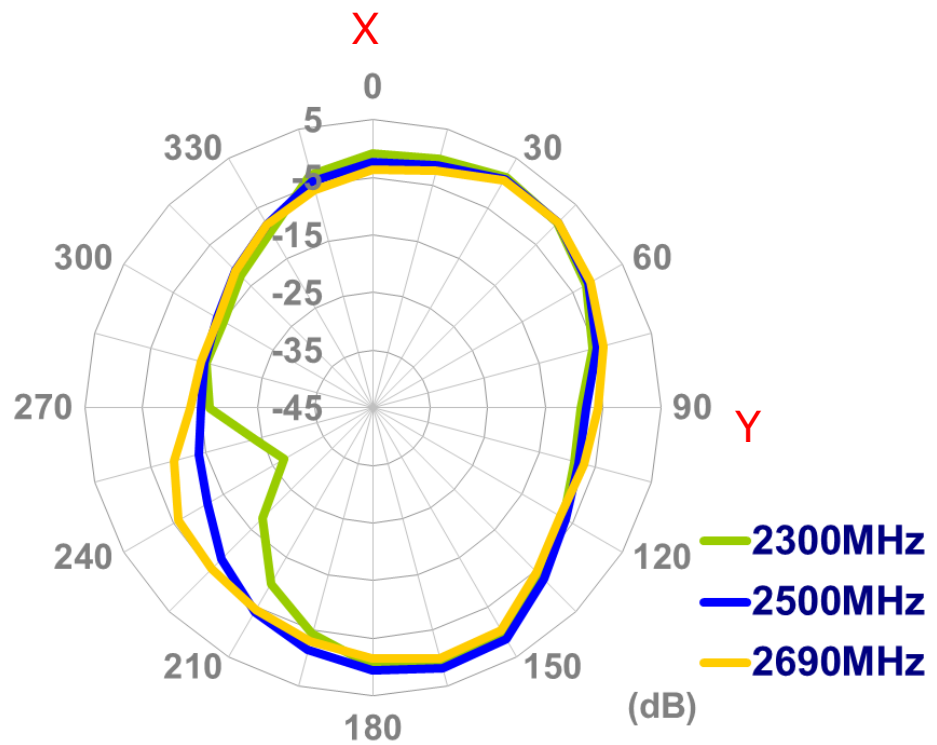

XZ Plane

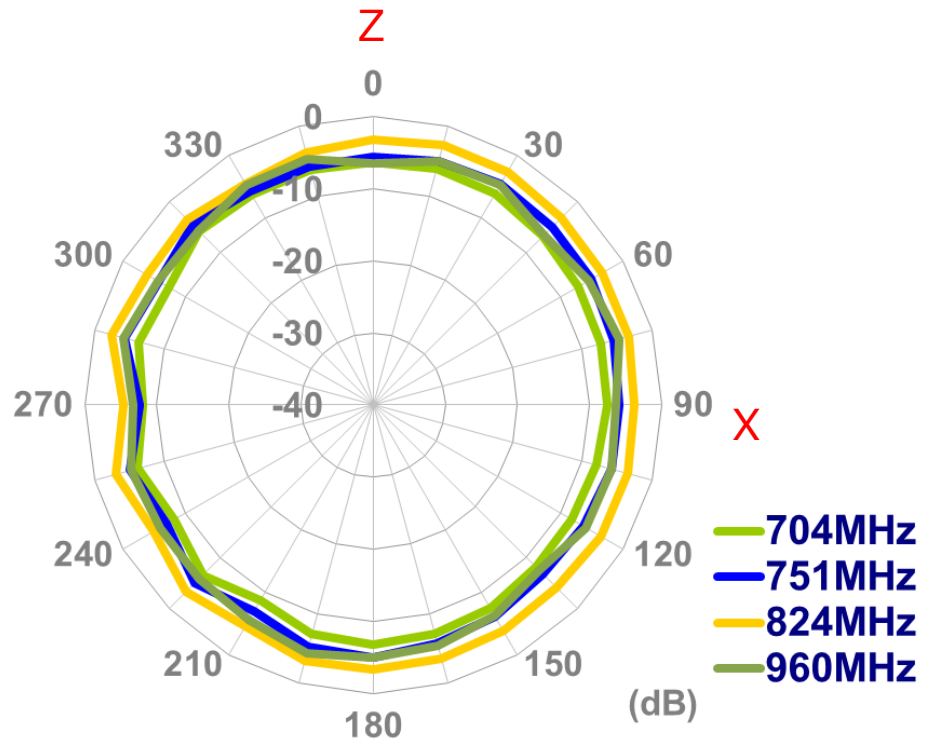

XZ Plane

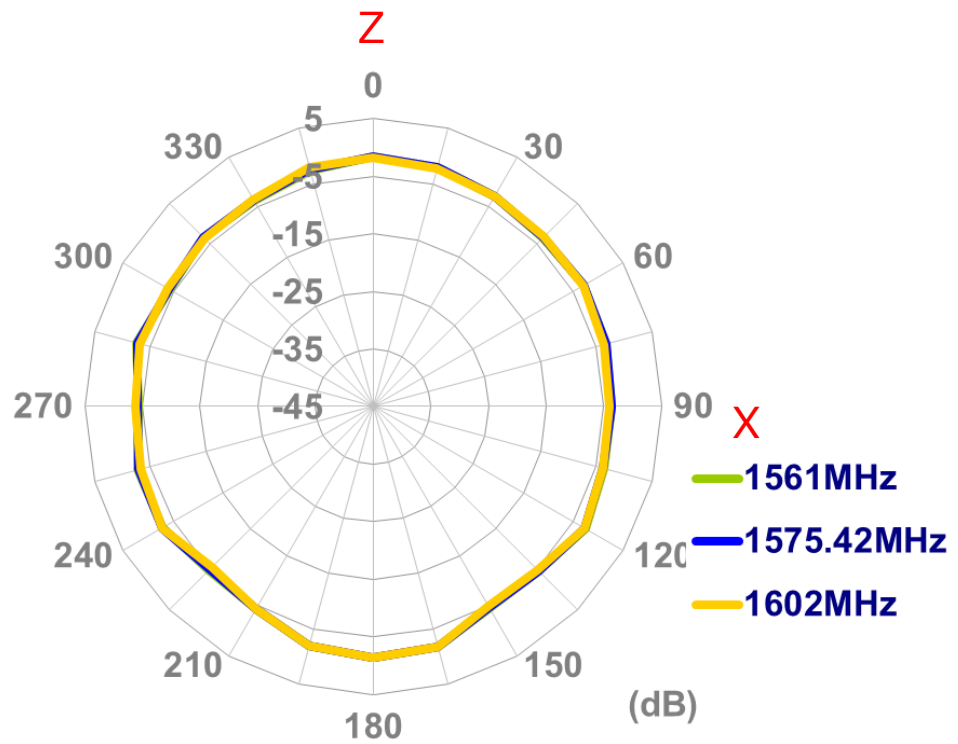

XZ Plane

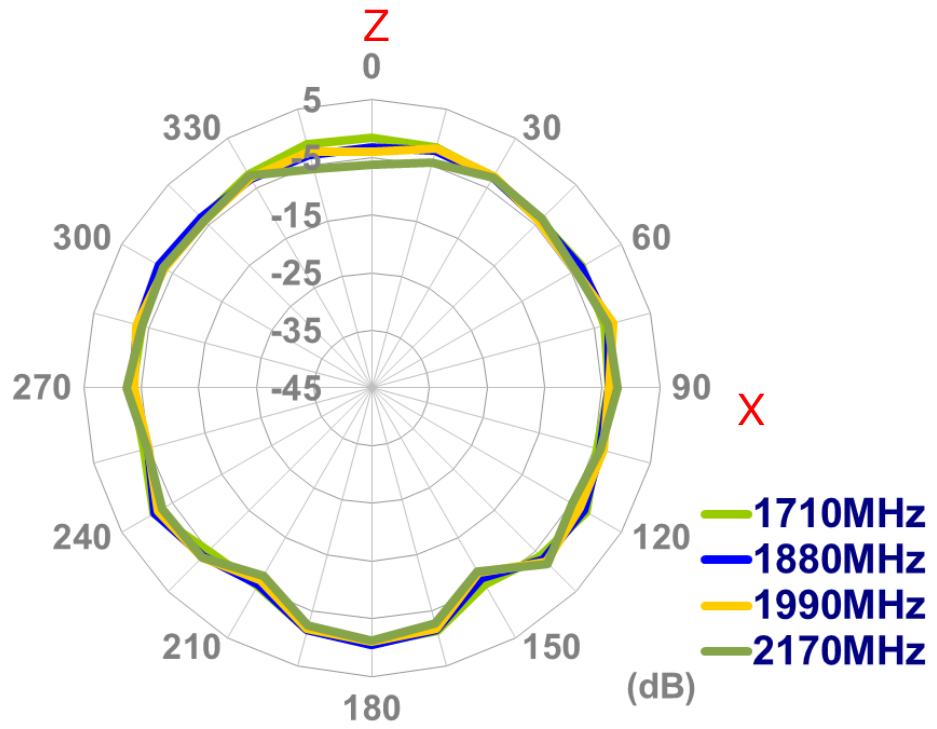

XZ Plane

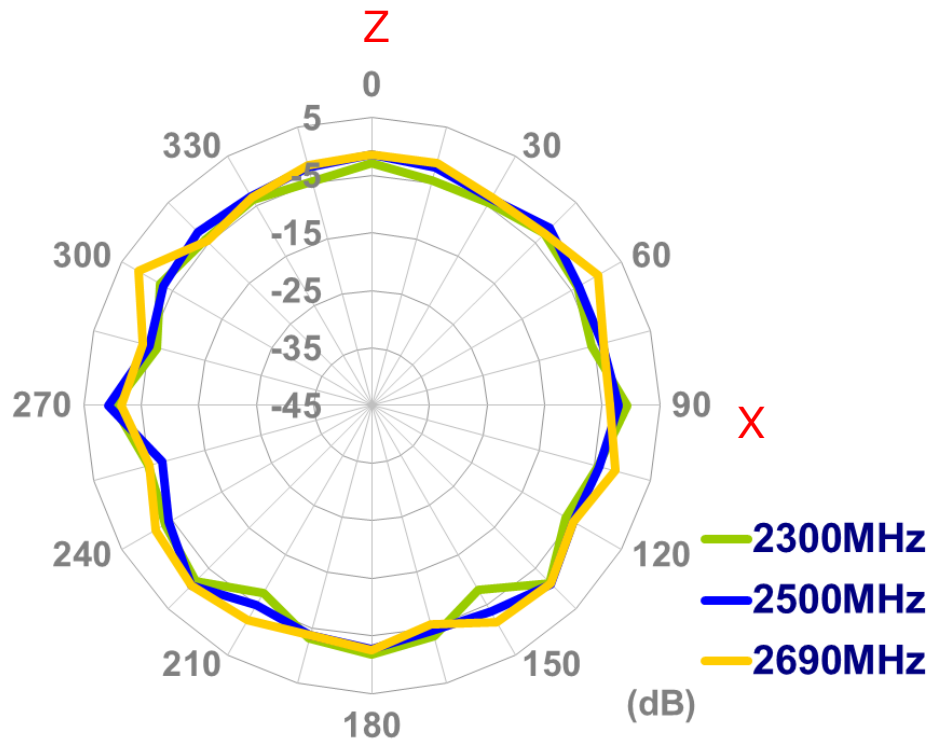

YZ Plane

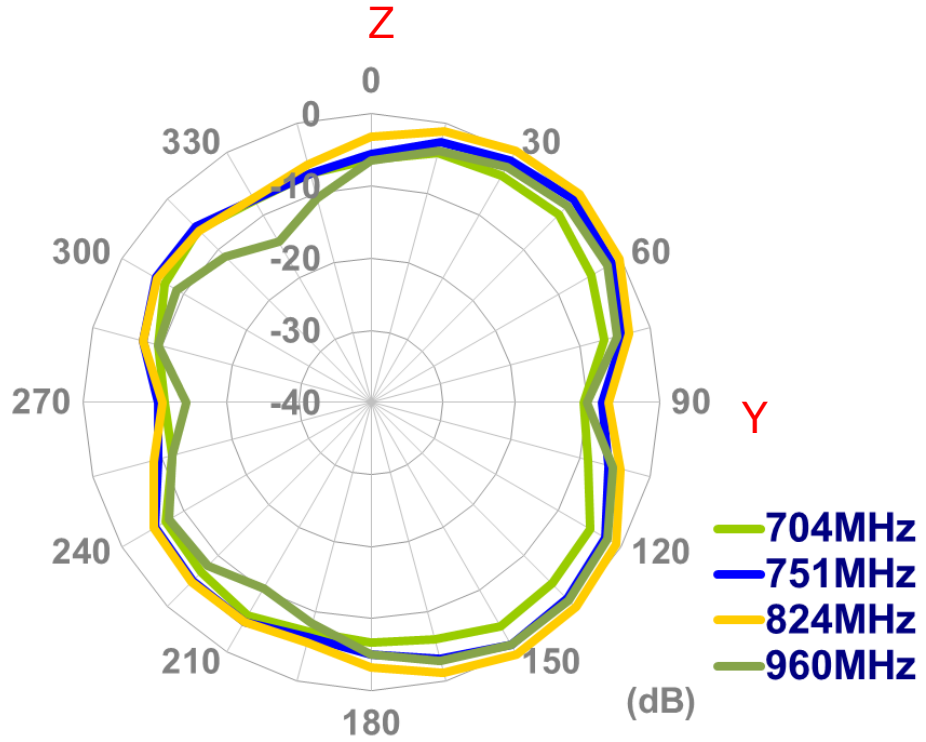

YZ Plane

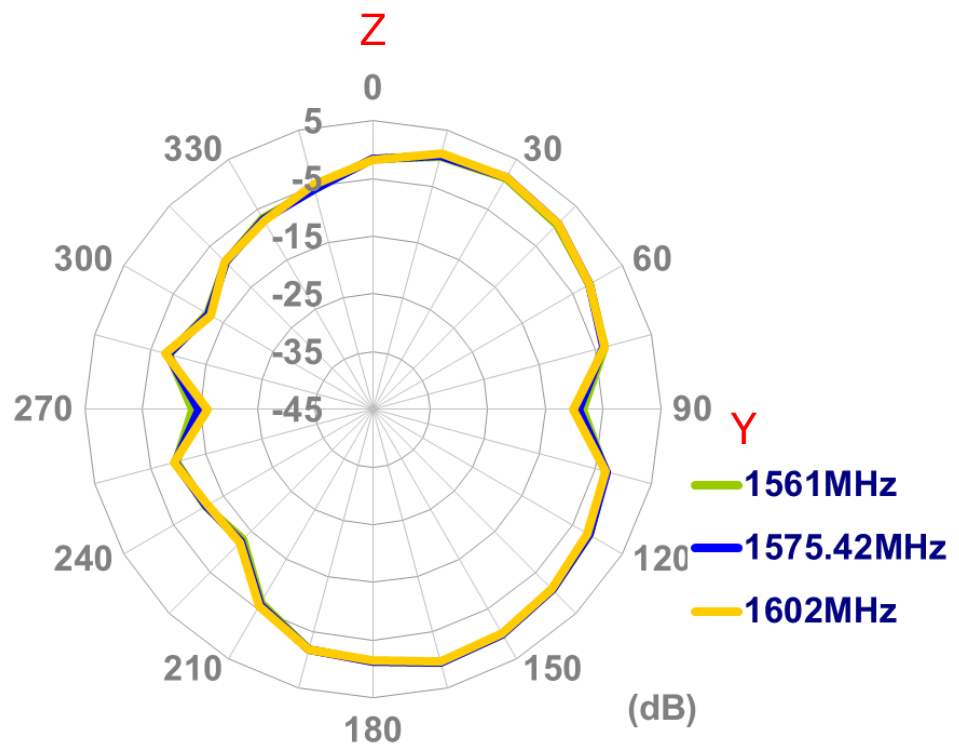

YZ Plane

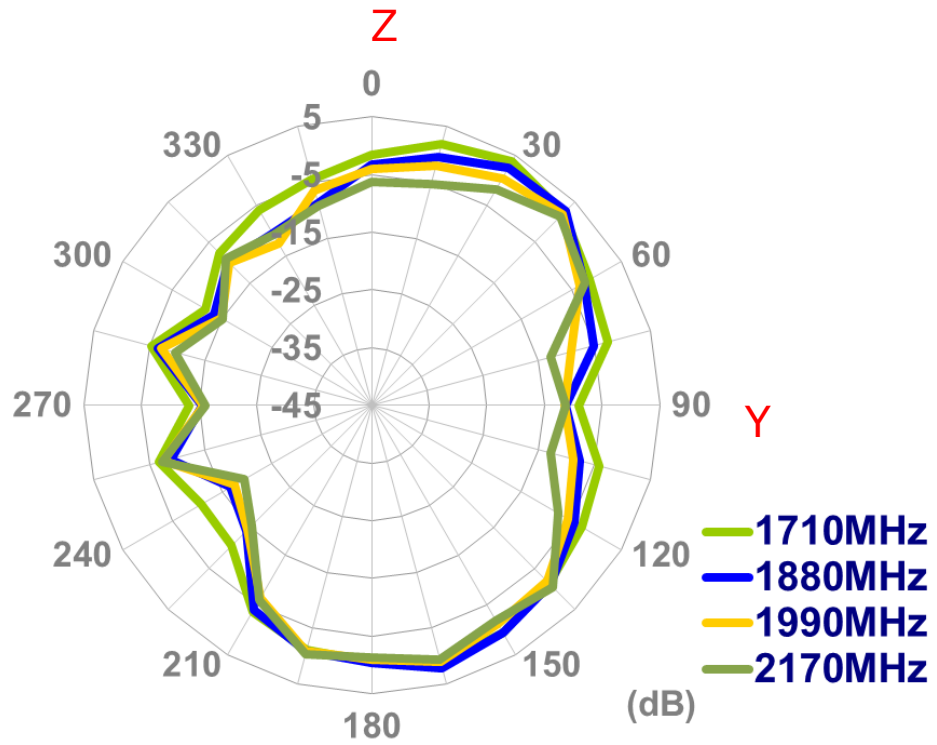

YZ Plane

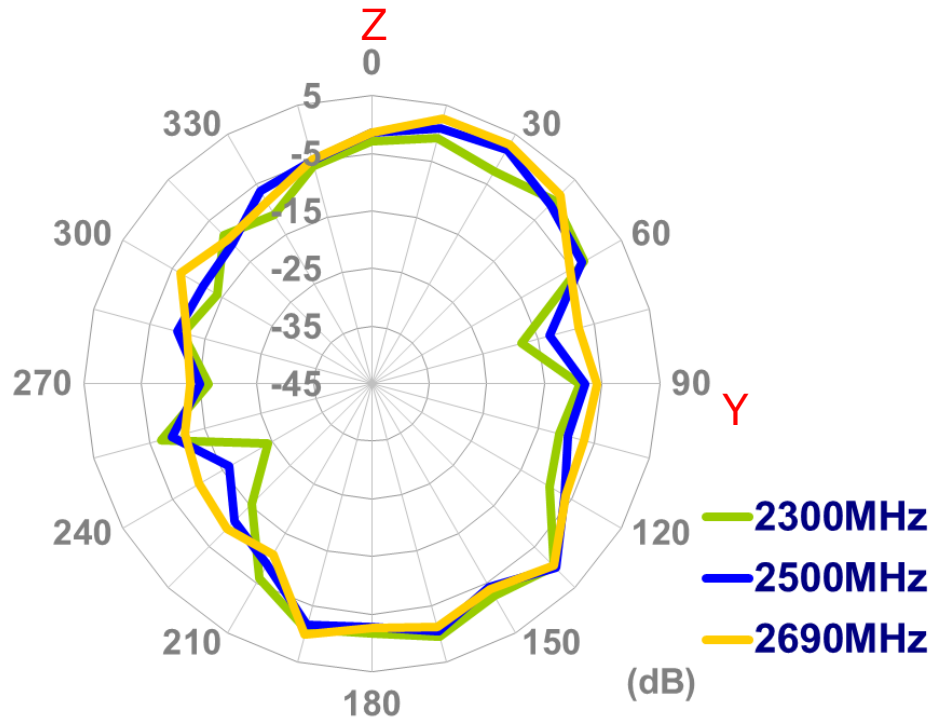

4.5 2D Radiation pattern (Bent Position in free space)

XY Plane

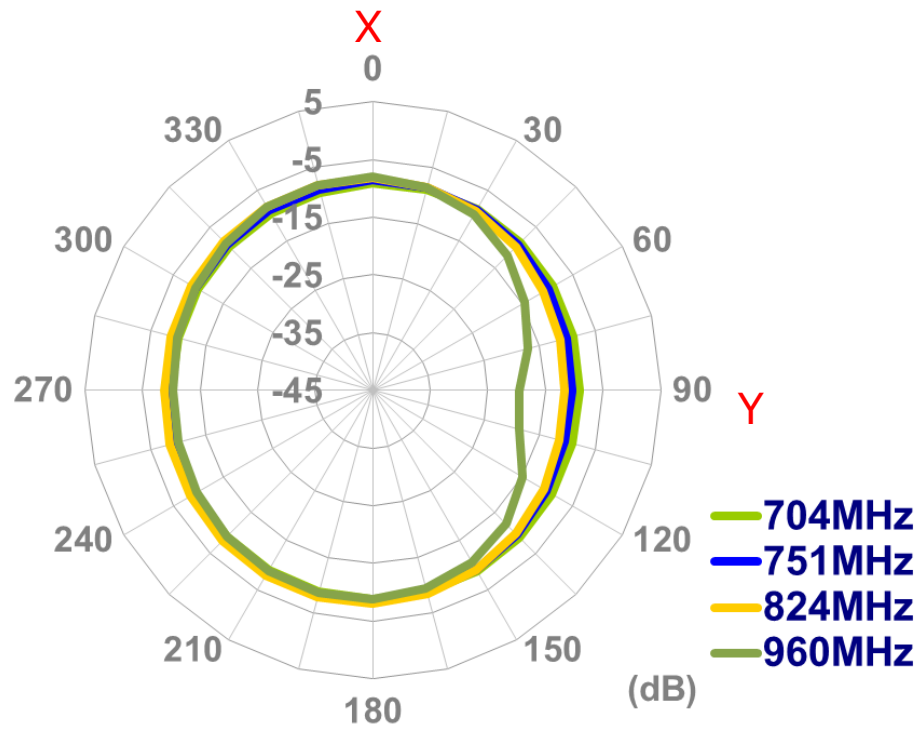

XY Plane

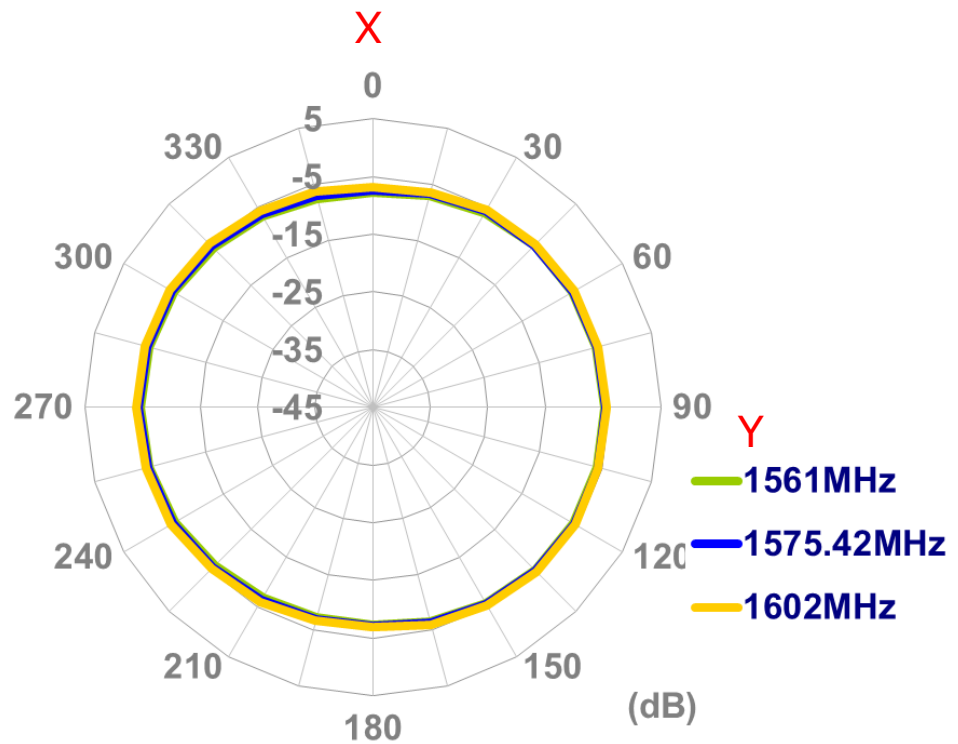

XY Plane

X

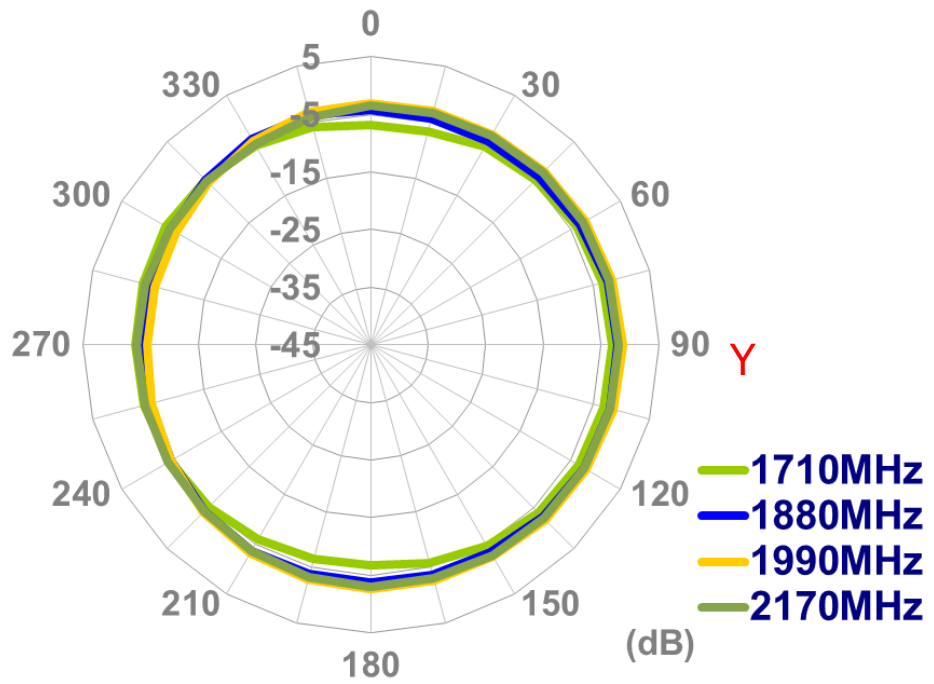

XY Plane

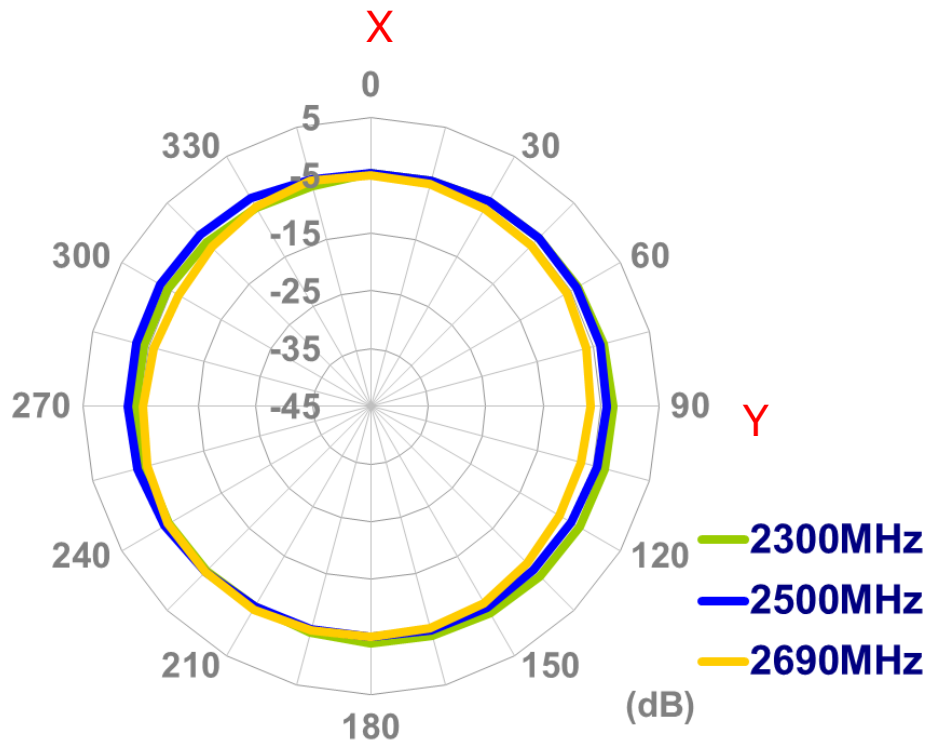

XZ Plane

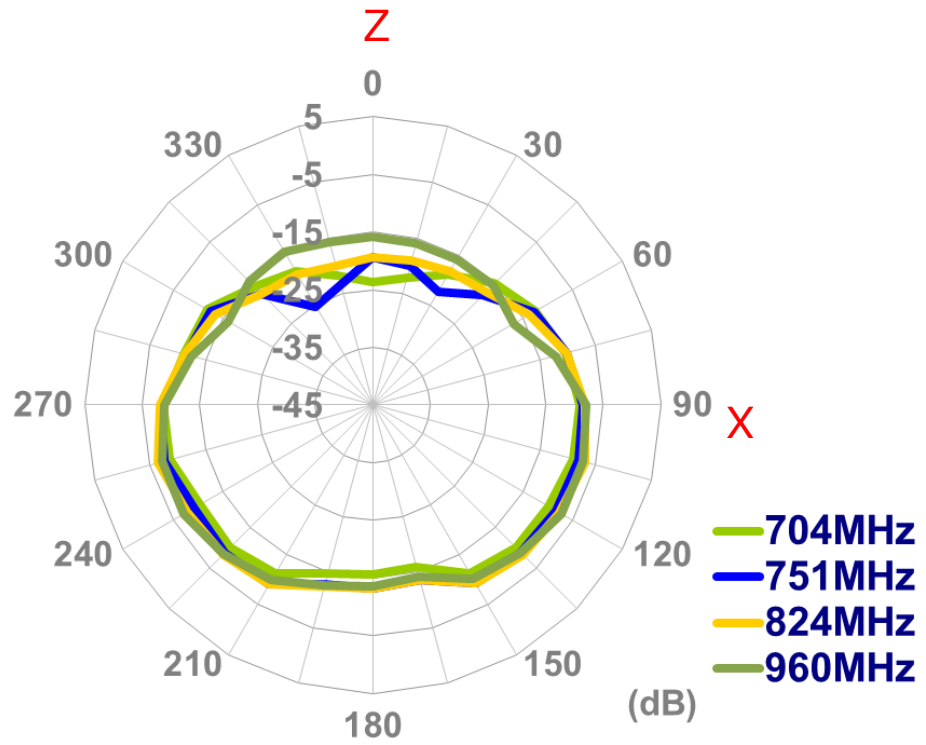

XZ Plane

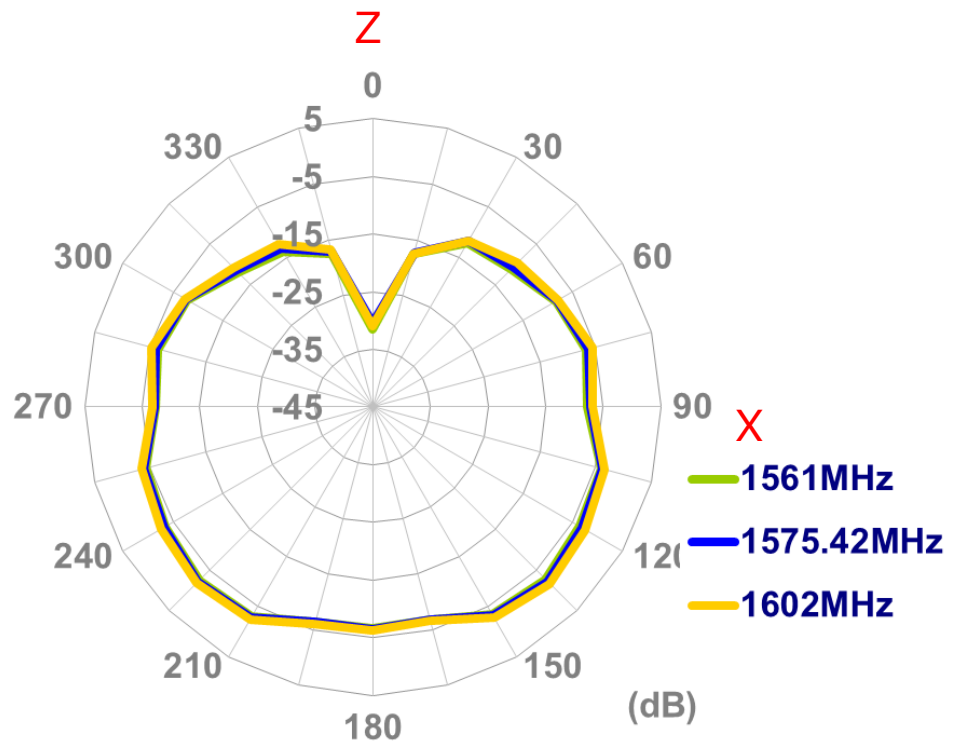

XZ Plane

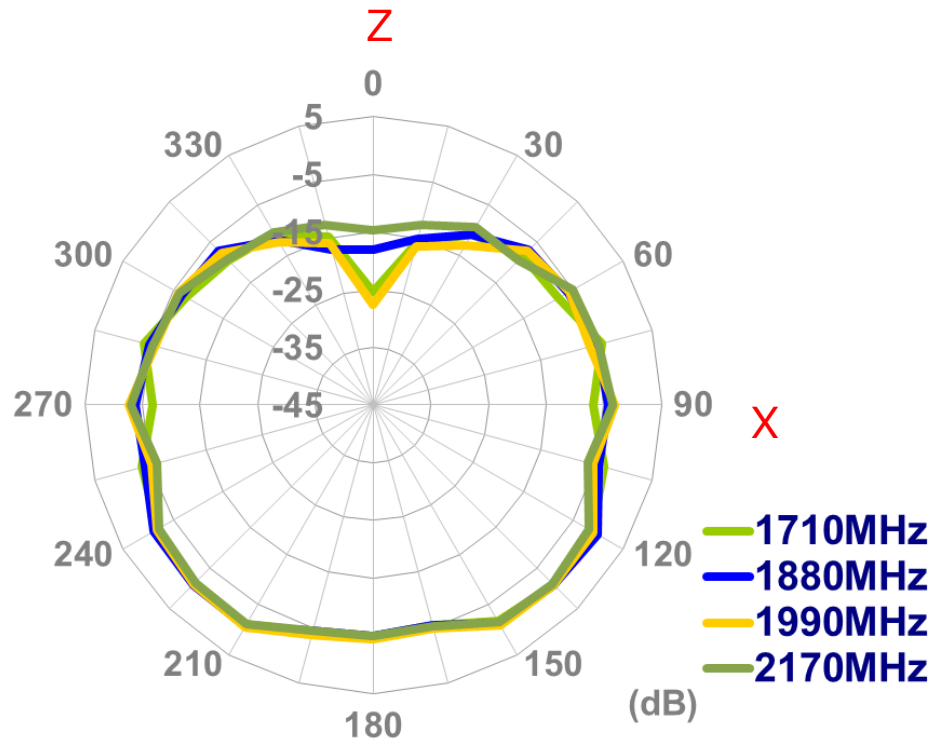

XZ Plane

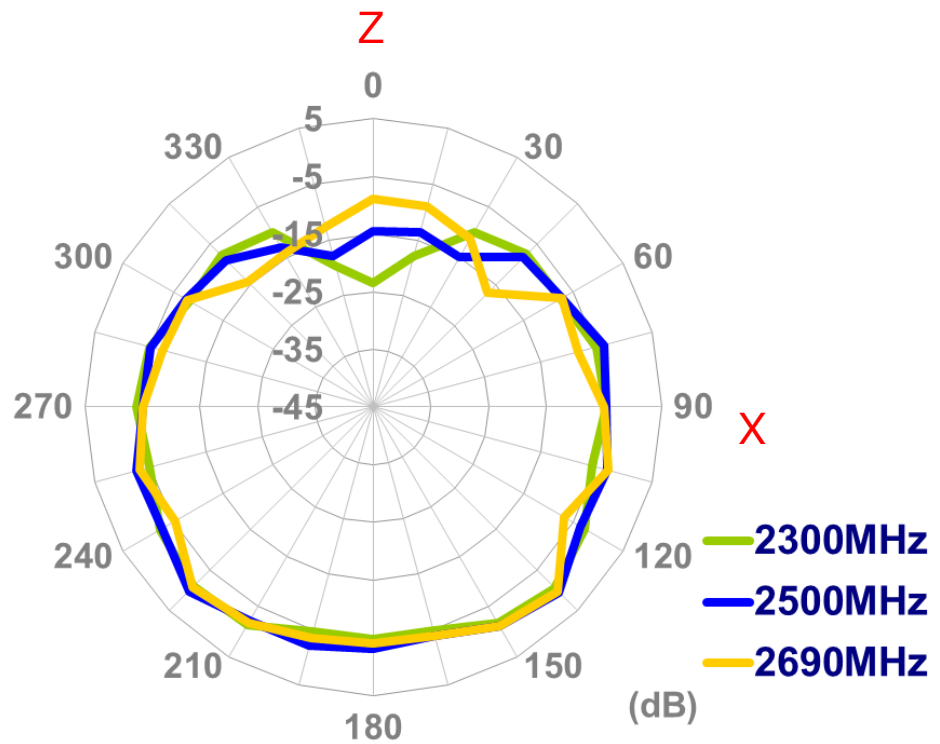

YZ Plane

Z

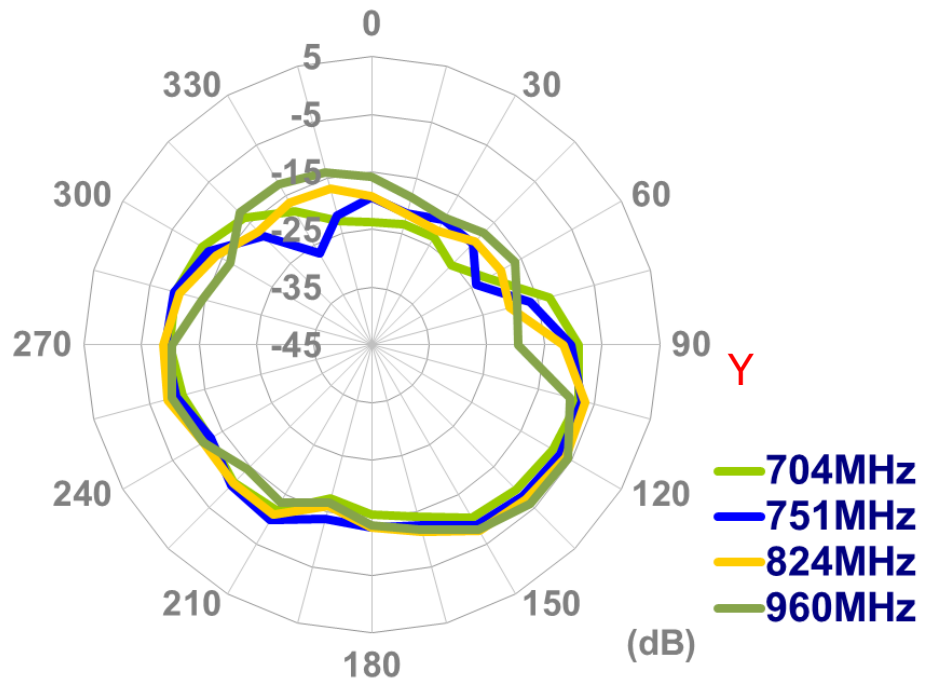

YZ Plane

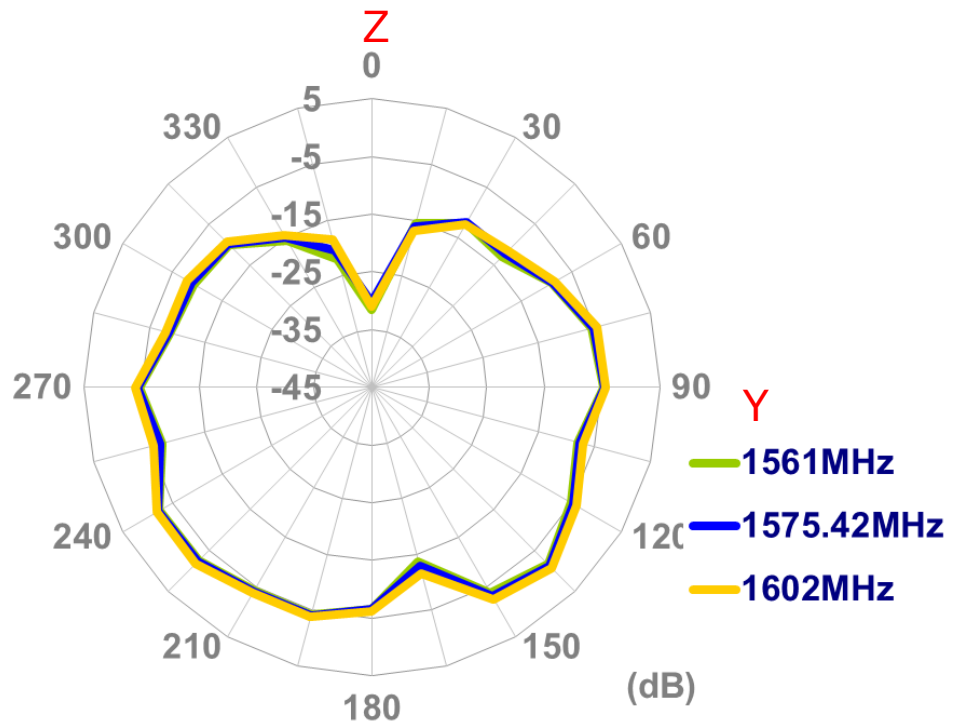

YZ Plane

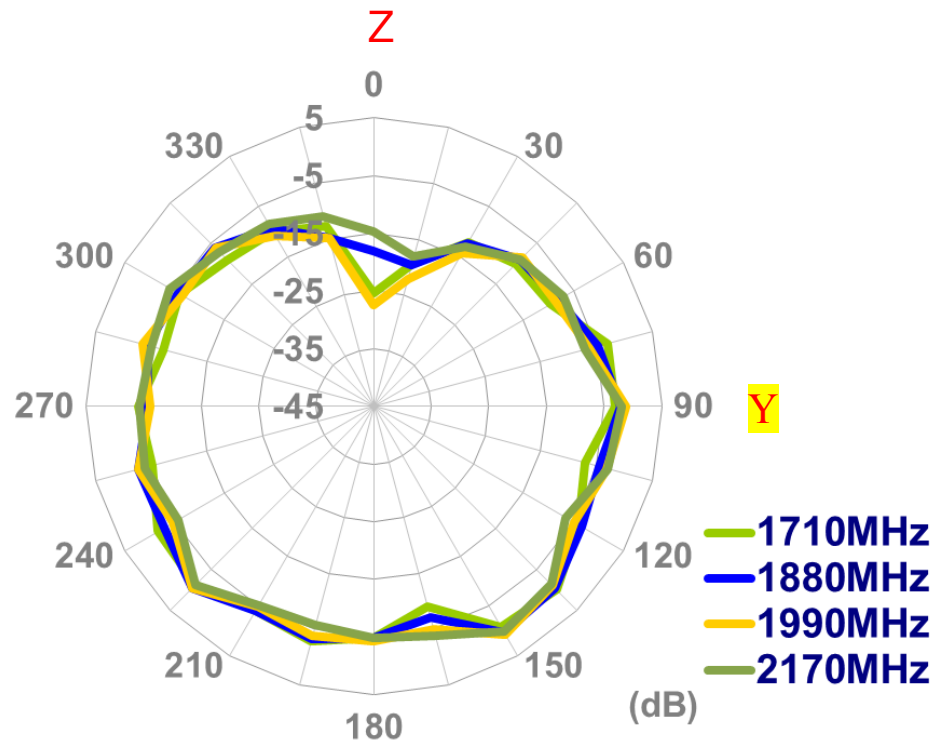

YZ Plane

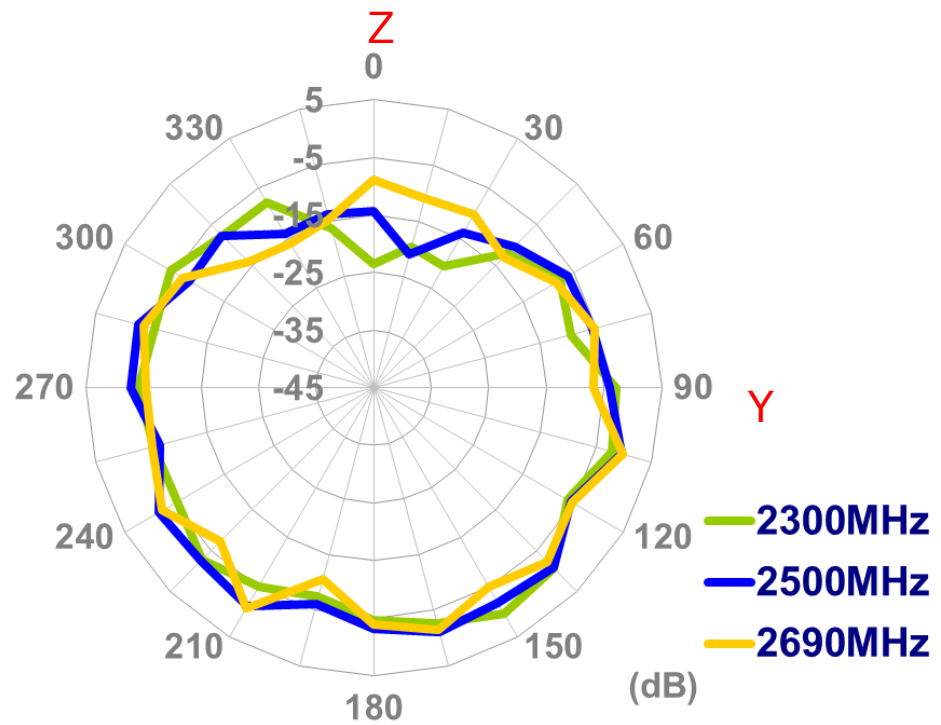

4.6 2D Radiation pattern (Bent Position with 15x9cm ground)

XY Plane

X

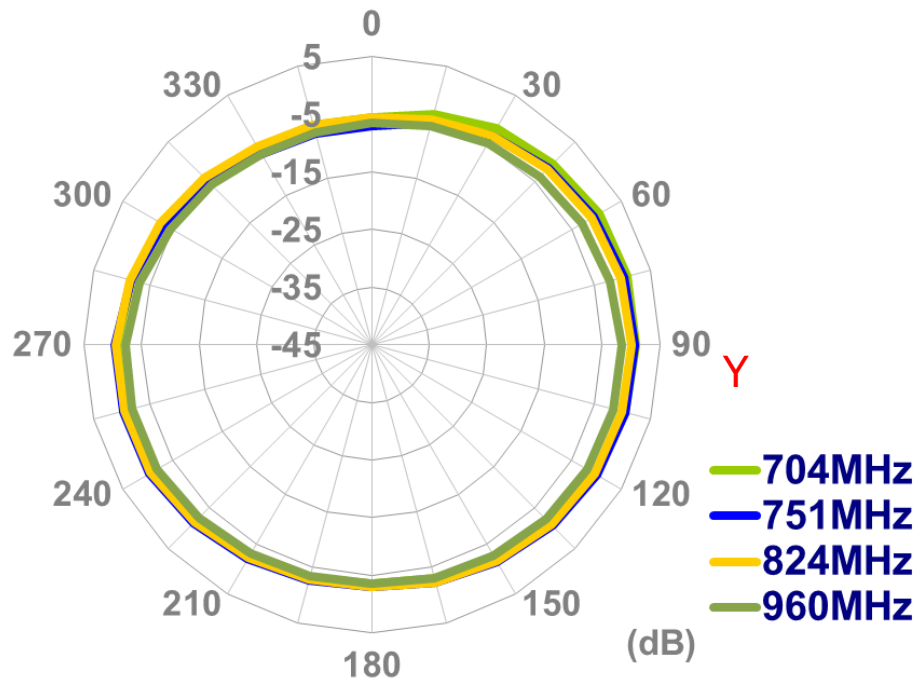

XY Plane

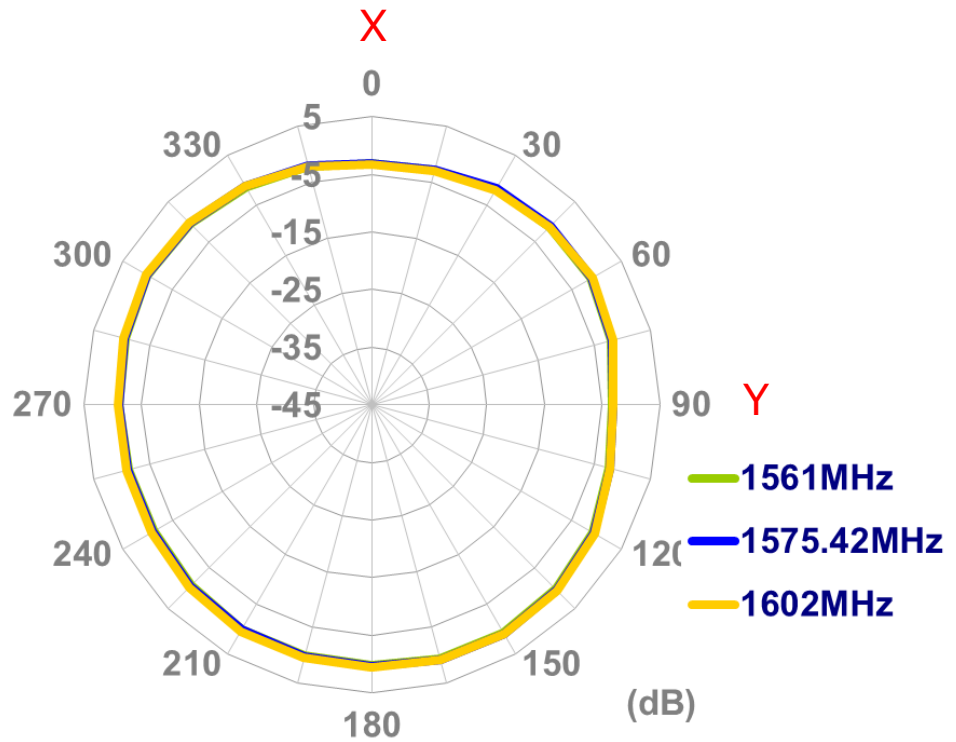

XY Plane

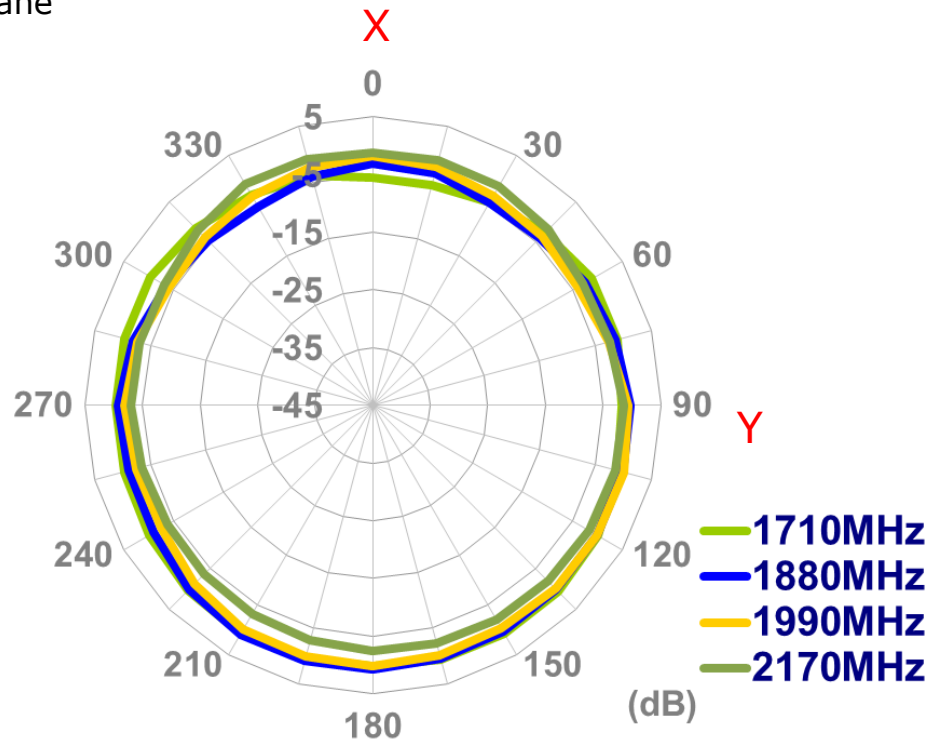

XY Plane

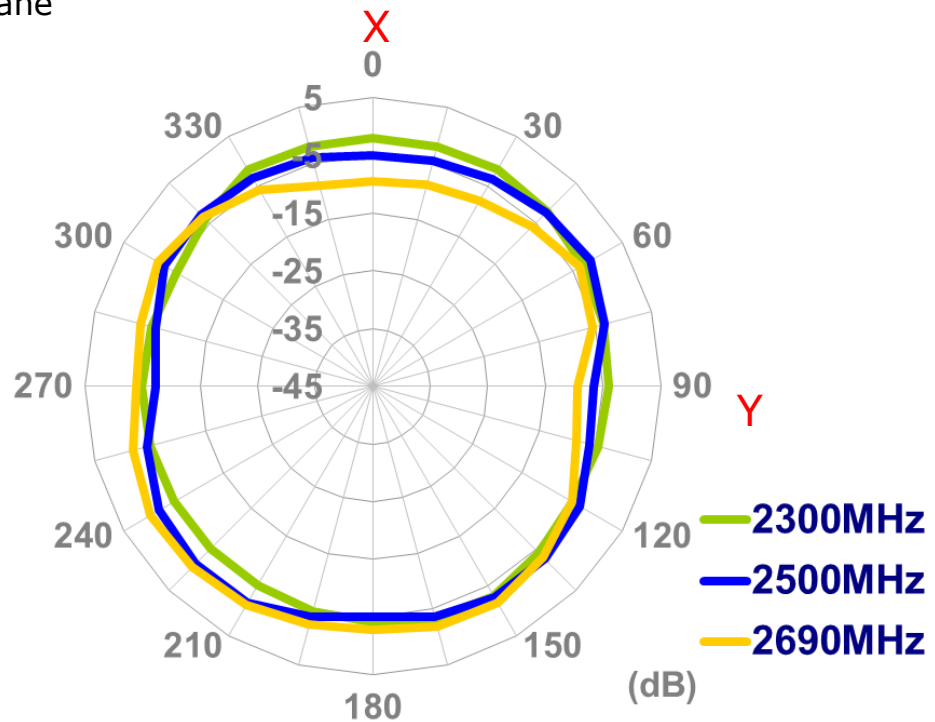

XZ Plane

Z

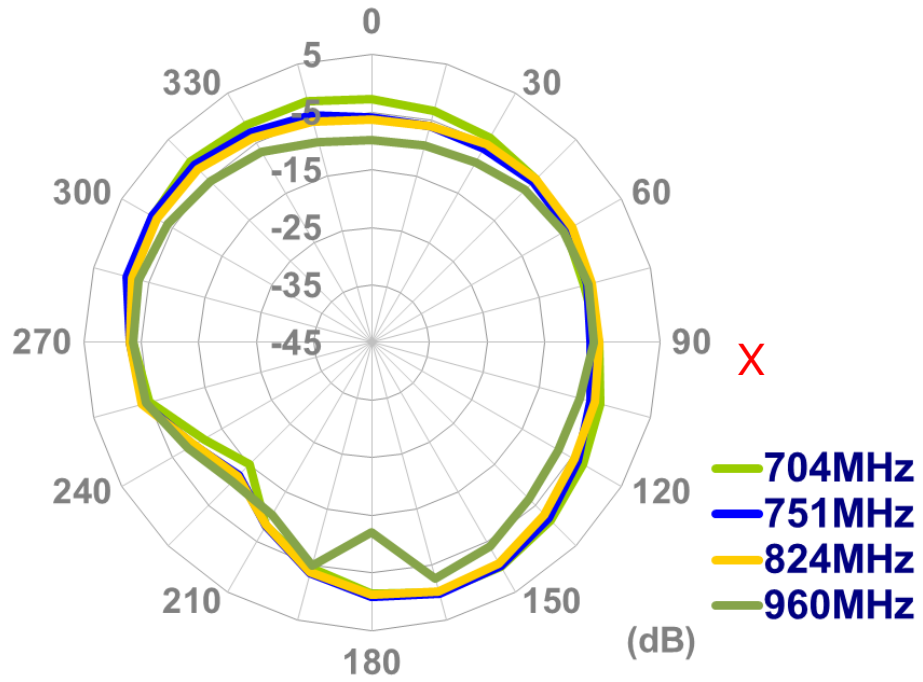

XZ Plane

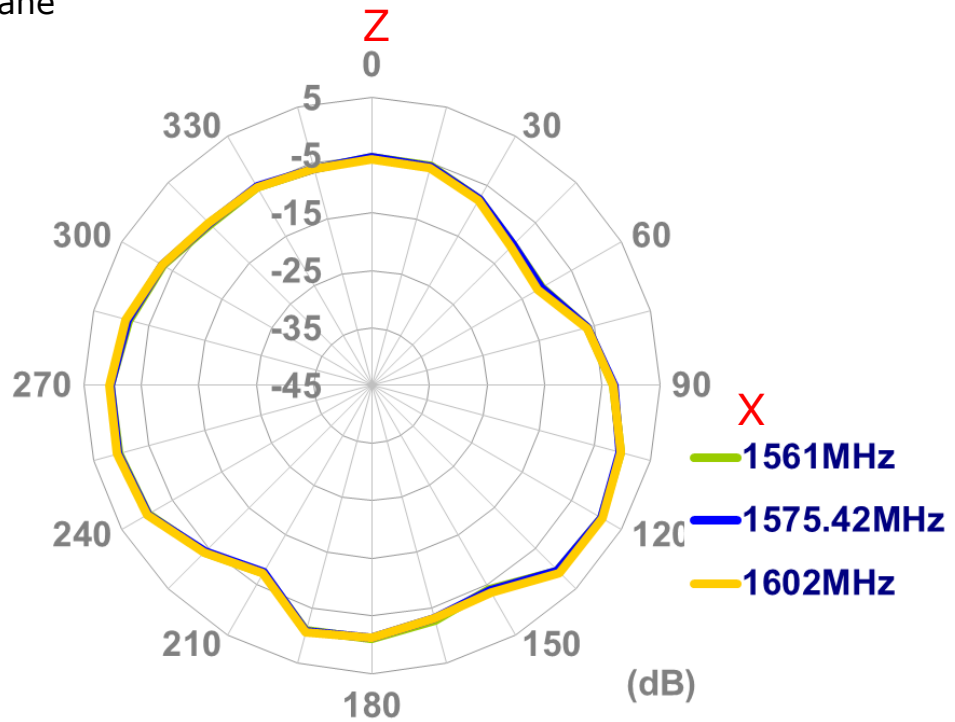

XZ Plane

Z

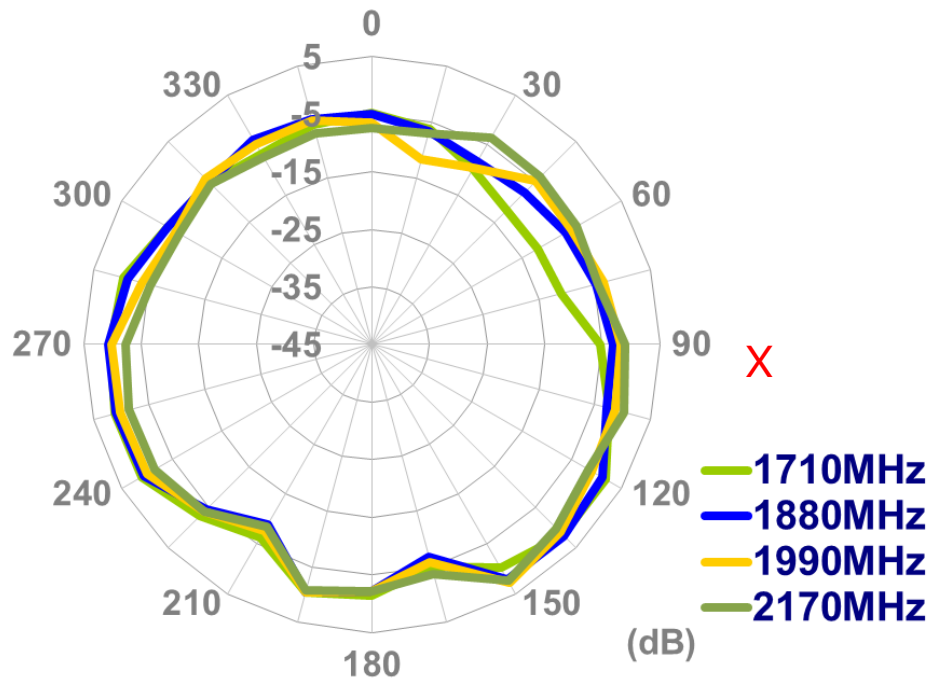

XZ Plane

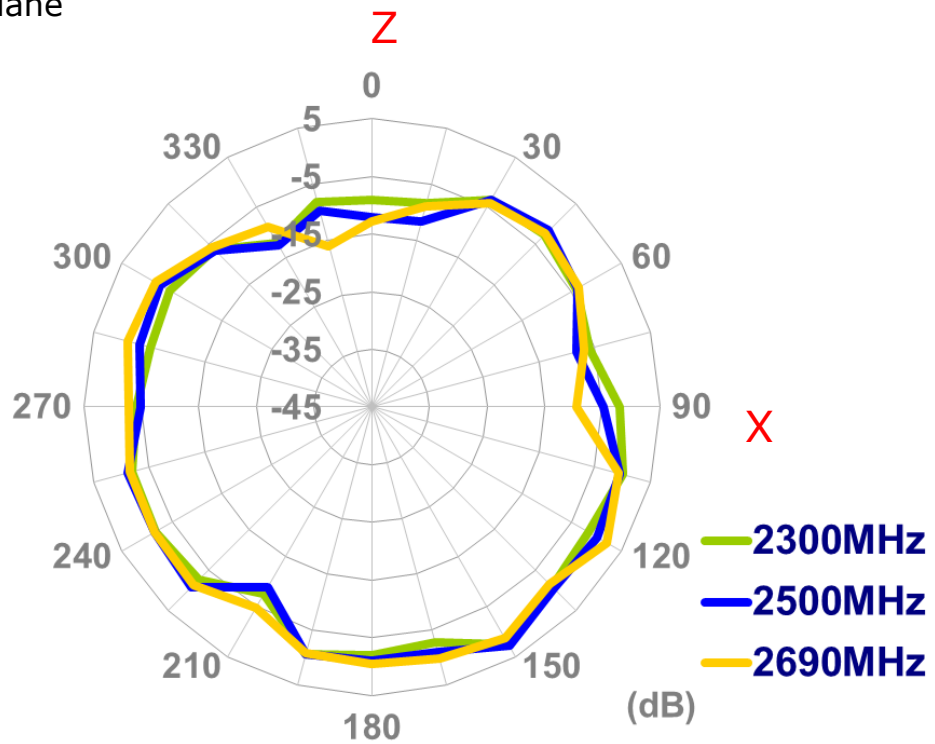

YZ Plane

Z

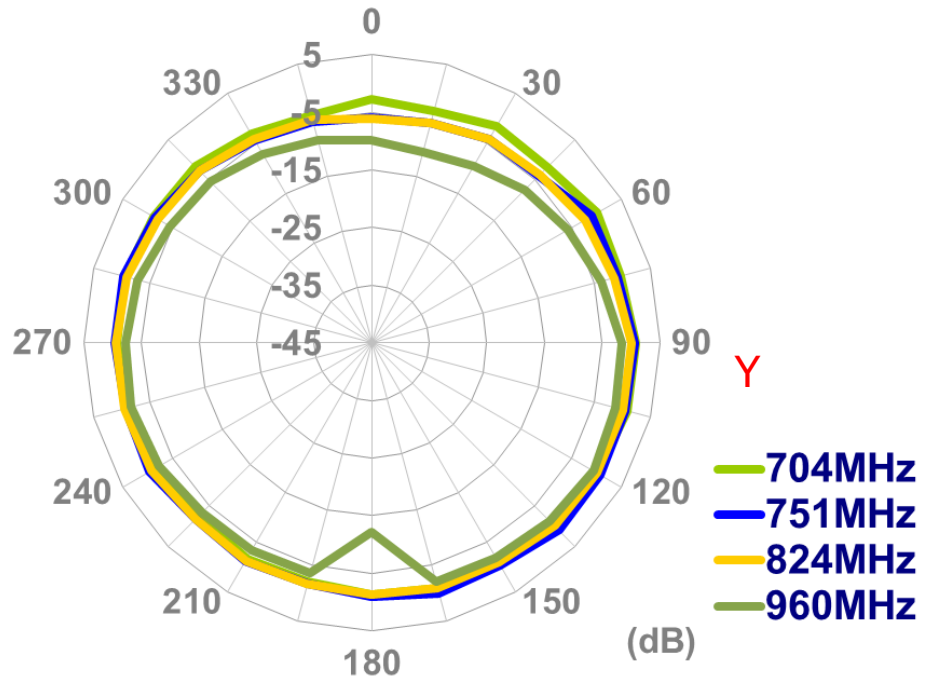

YZ Plane

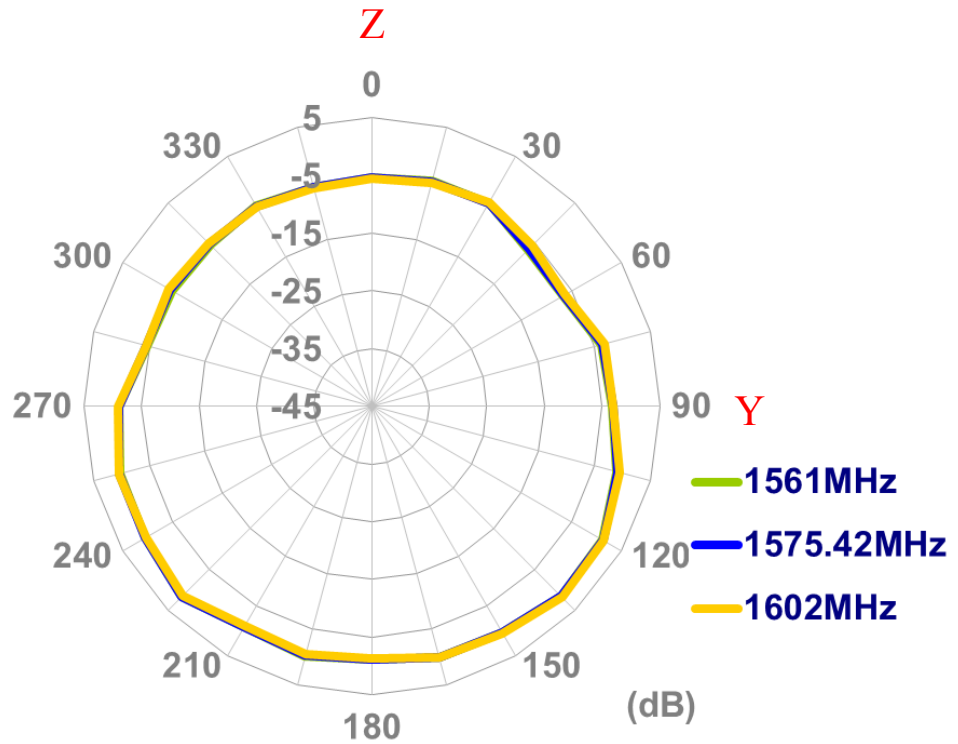

YZ Plane

Z

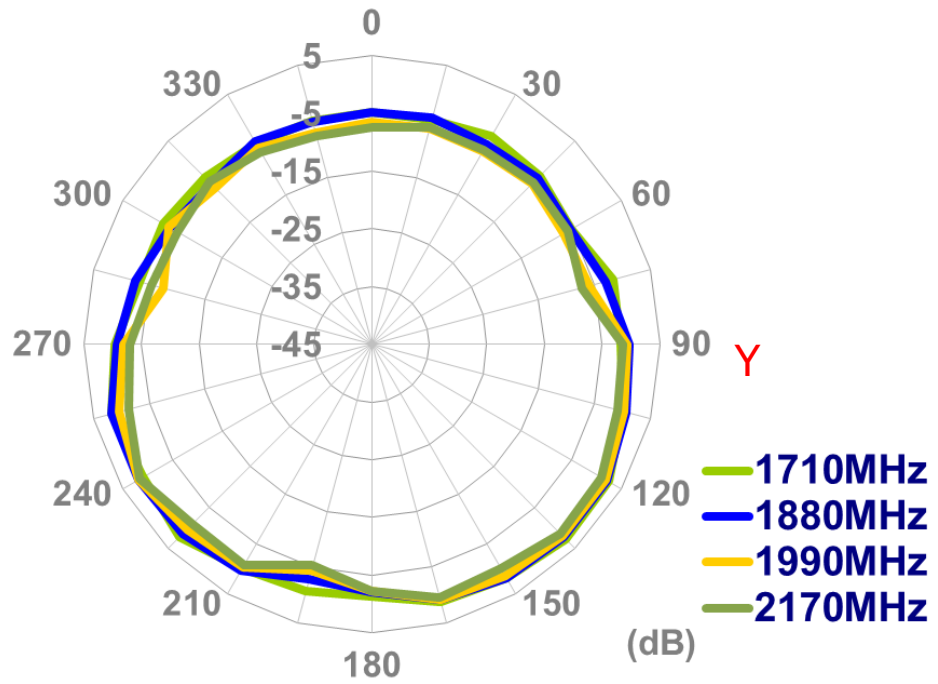

YZ Plane

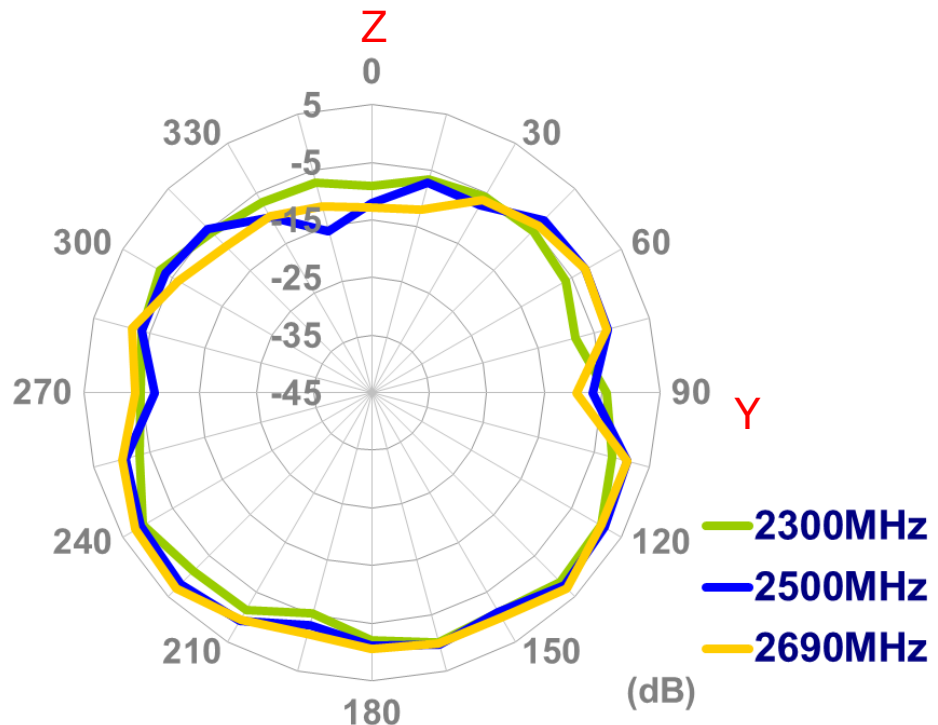

4.7 2D Radiation pattern (Bent Position with 30x30cm metal ground edge)

XY Plane

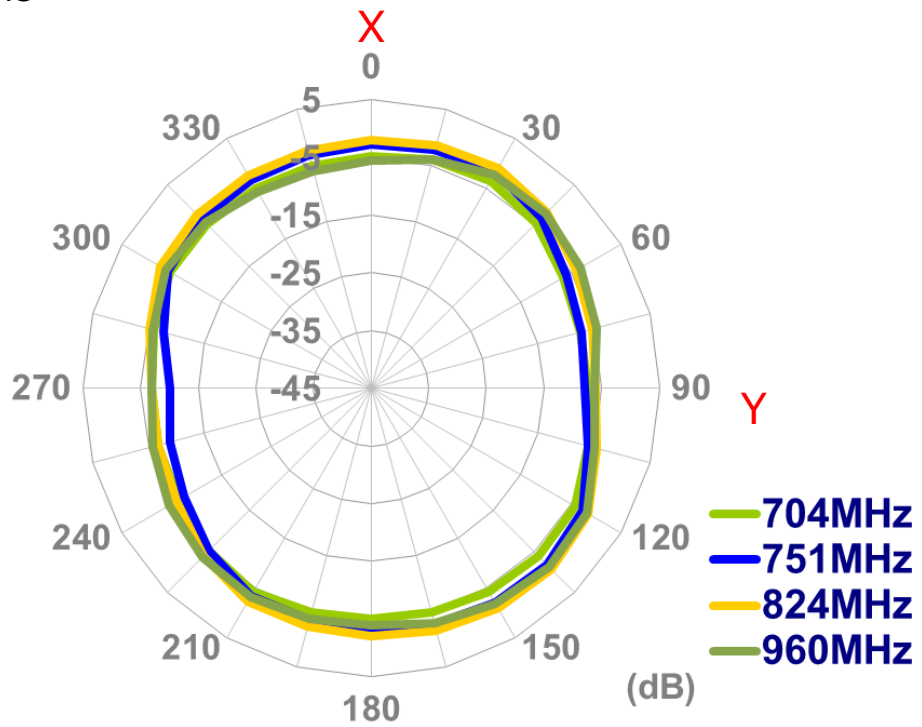

XY Plane

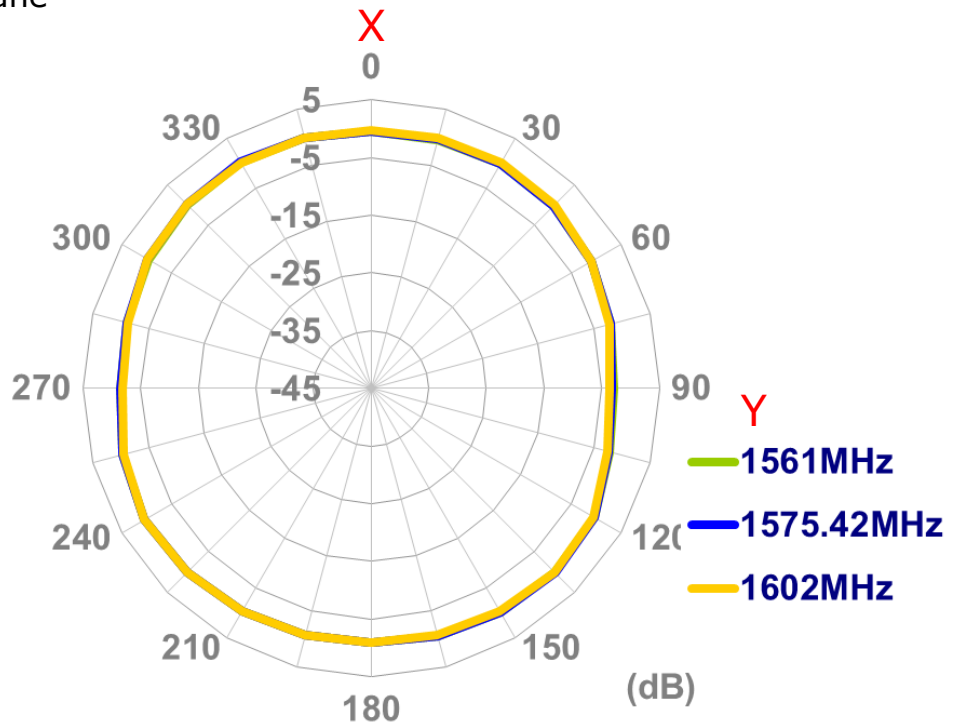

XY Plane

X

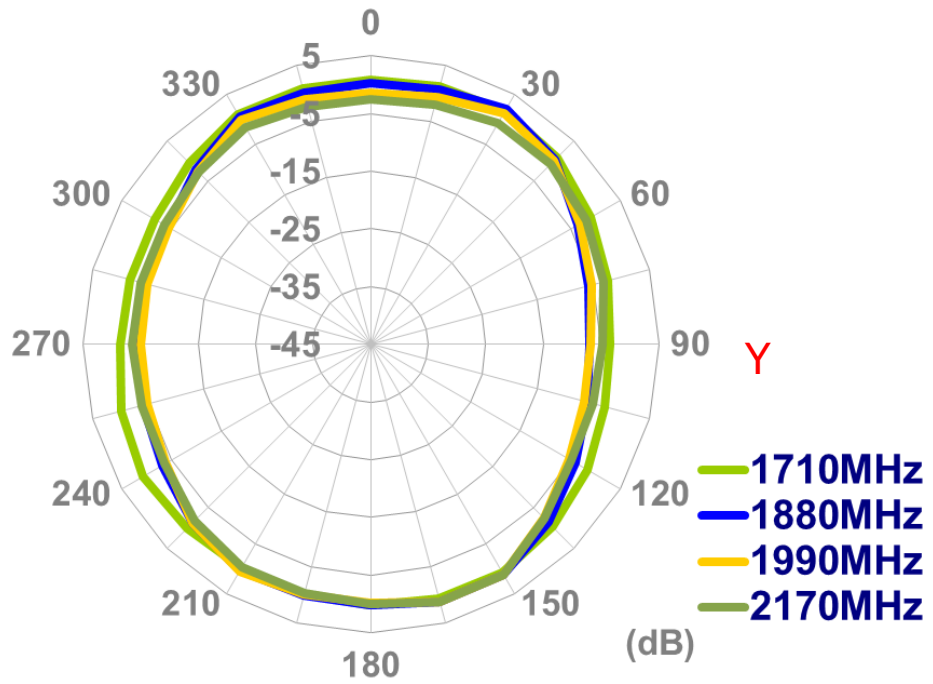

XY Plane

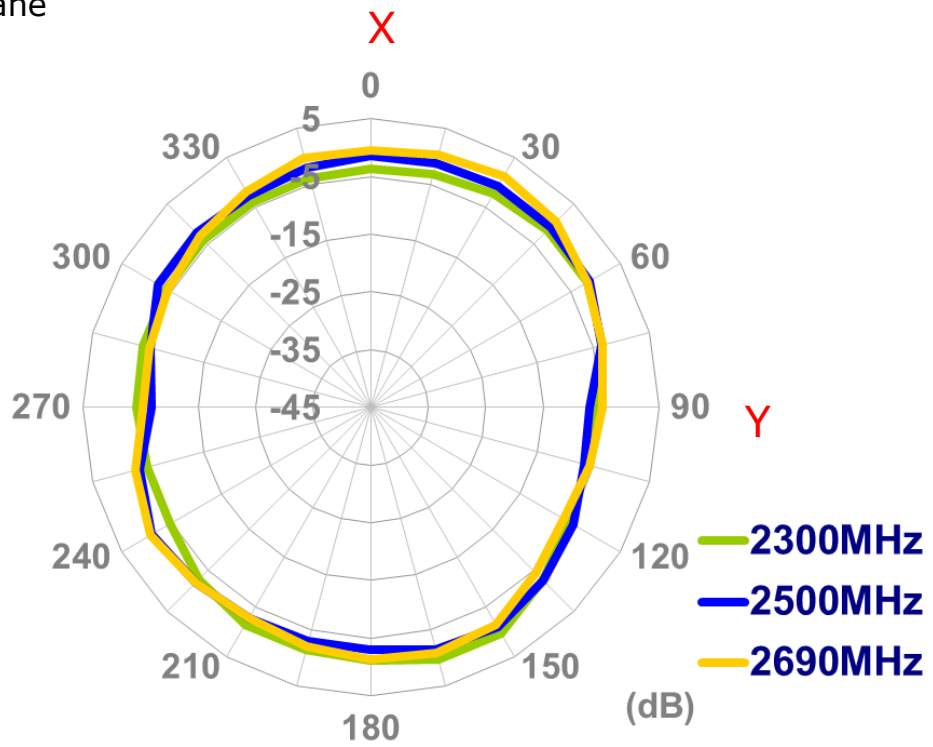

XZ Plane

Z

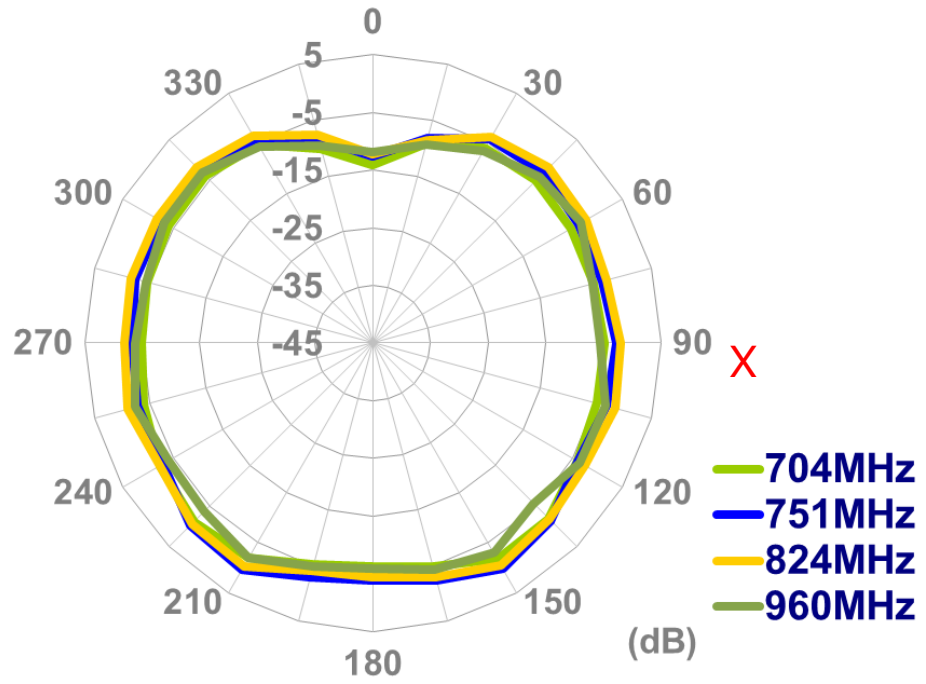

XZ Plane

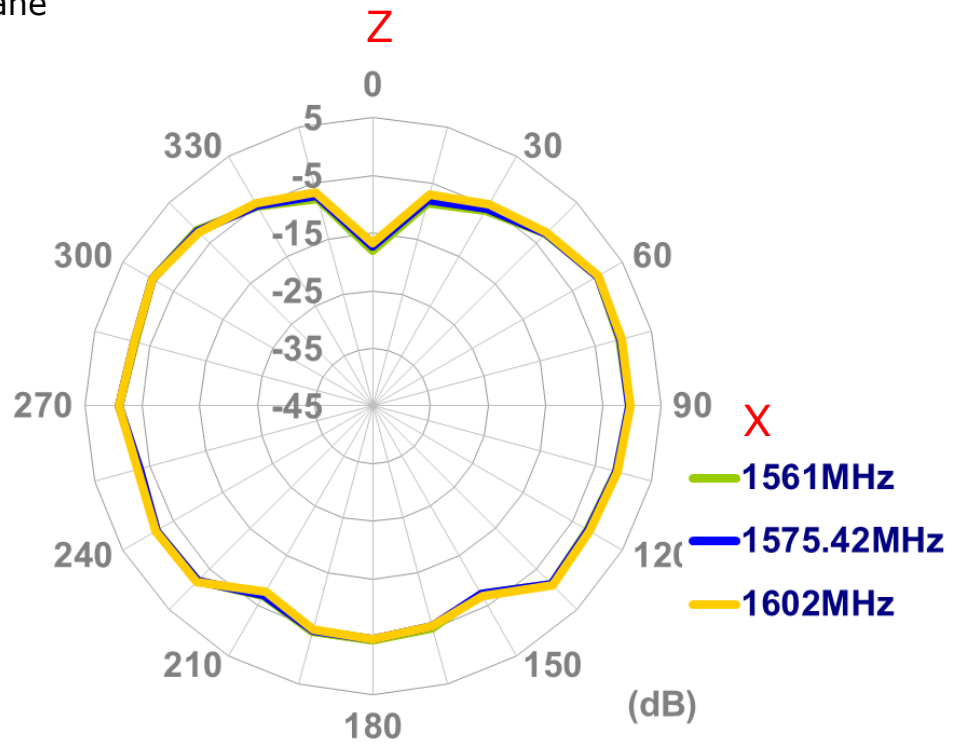

XZ Plane

Z

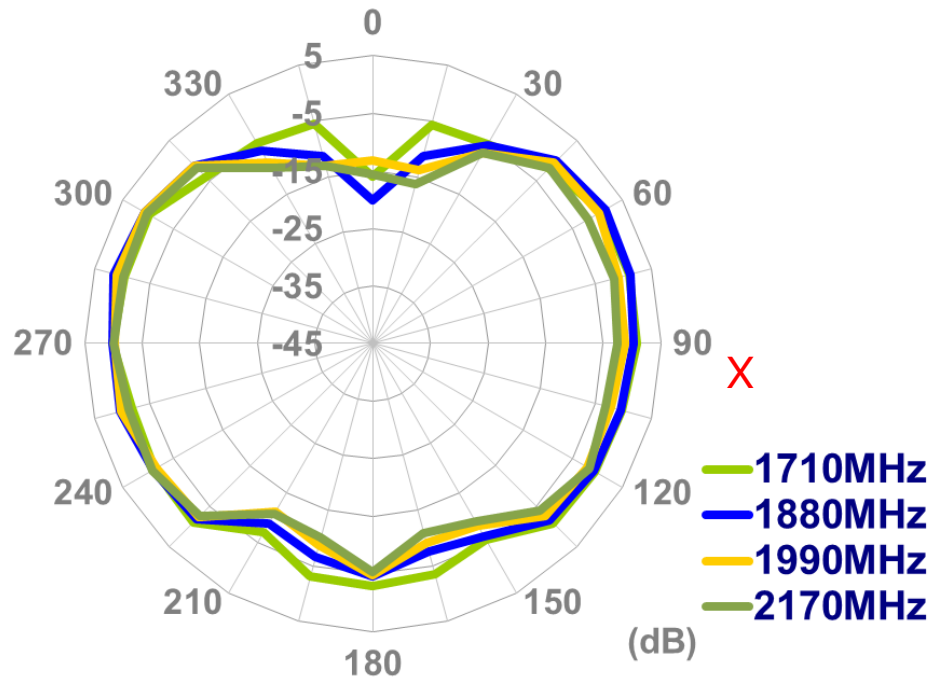

XZ Plane

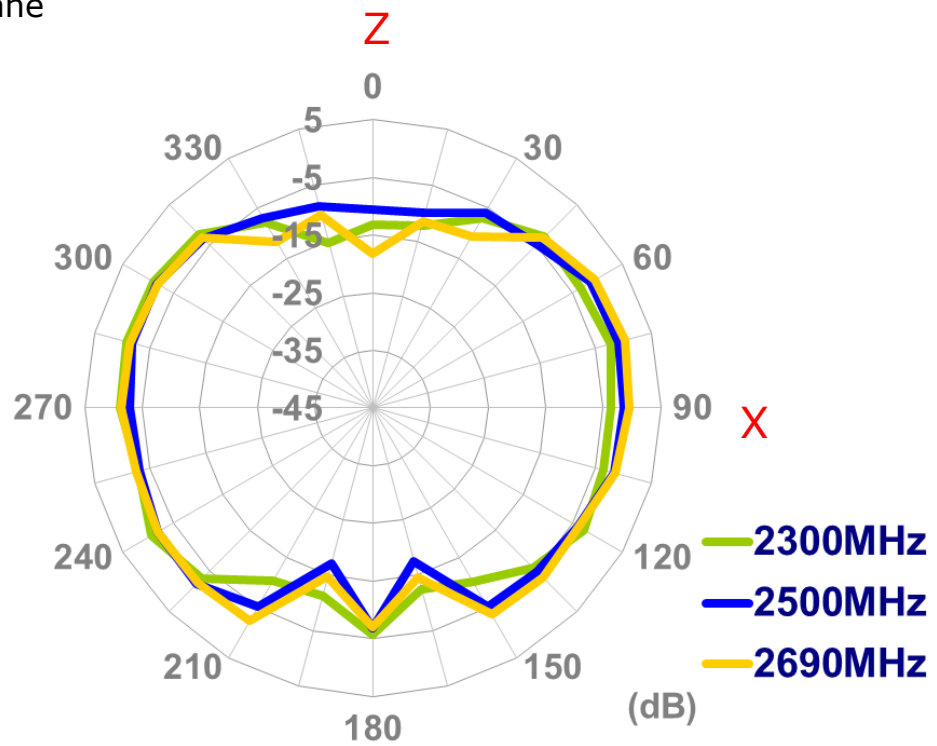

YZ Plane

Z

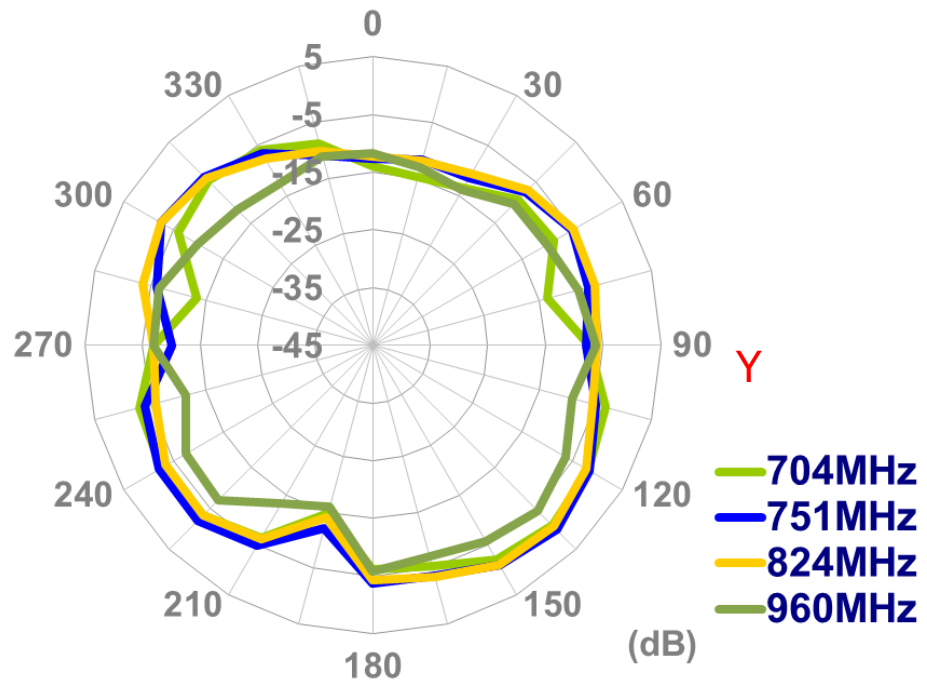

YZ Plane

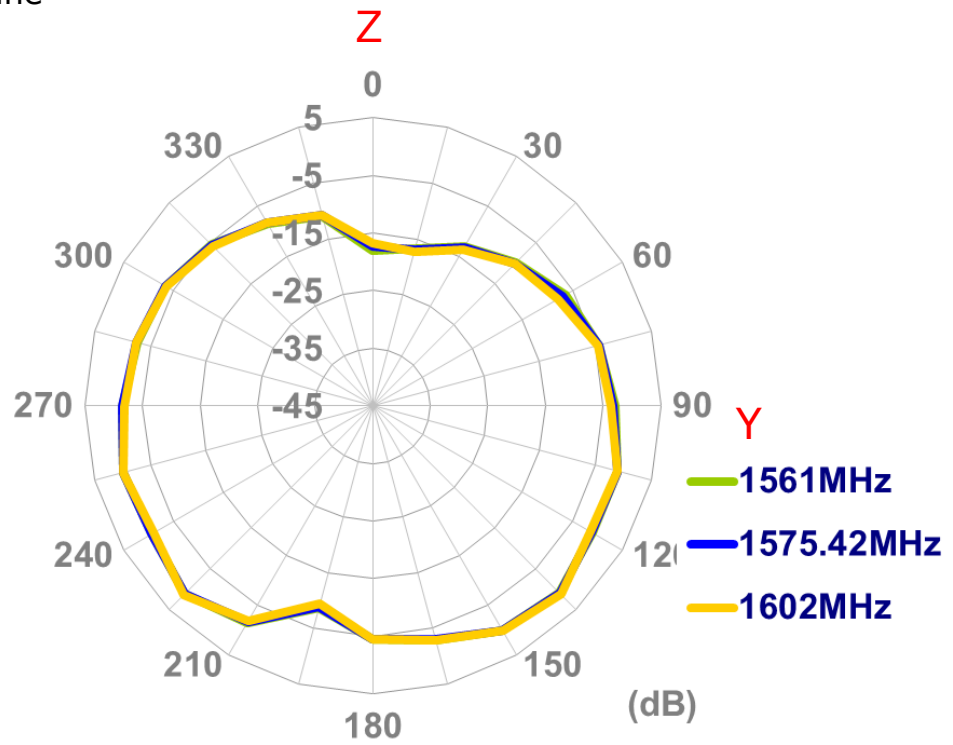

YZ Plane

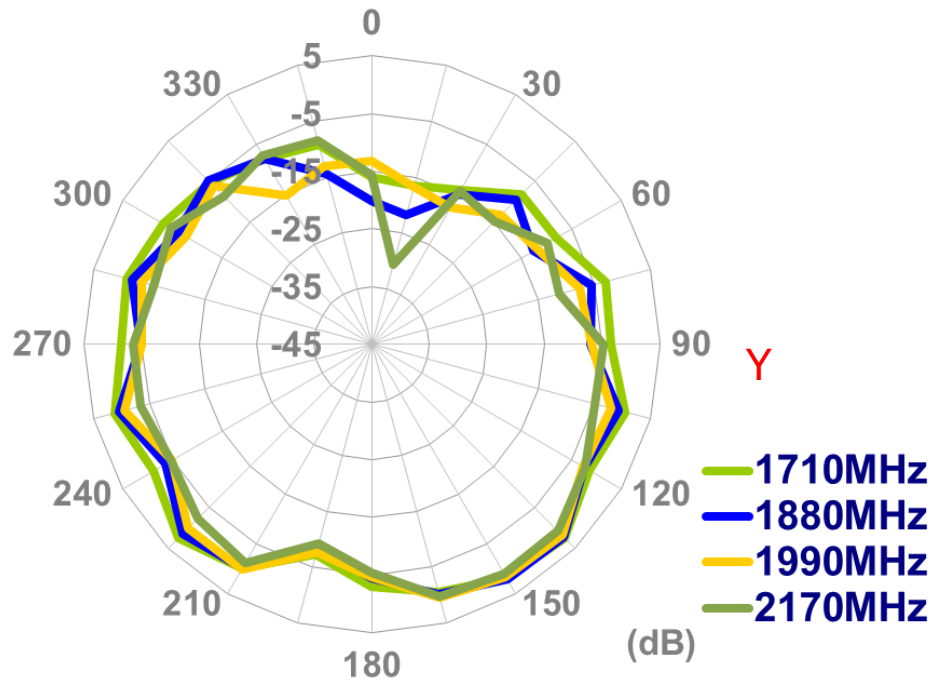

YZ Plane

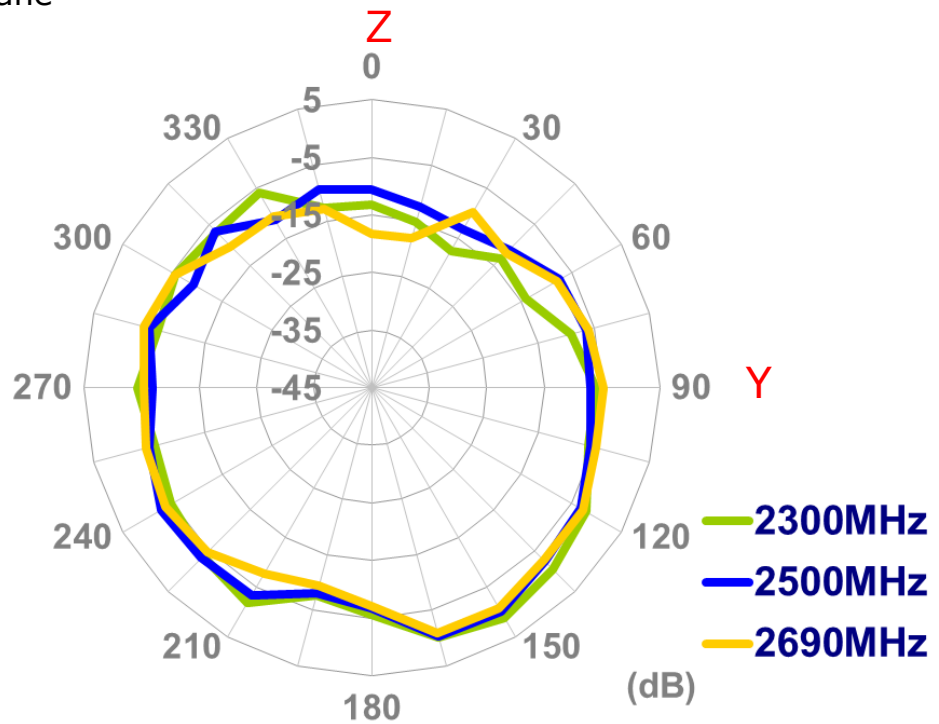

4.8 2D Radiation pattern (Bent Position with 30*30cm metal ground center)

XY Plane

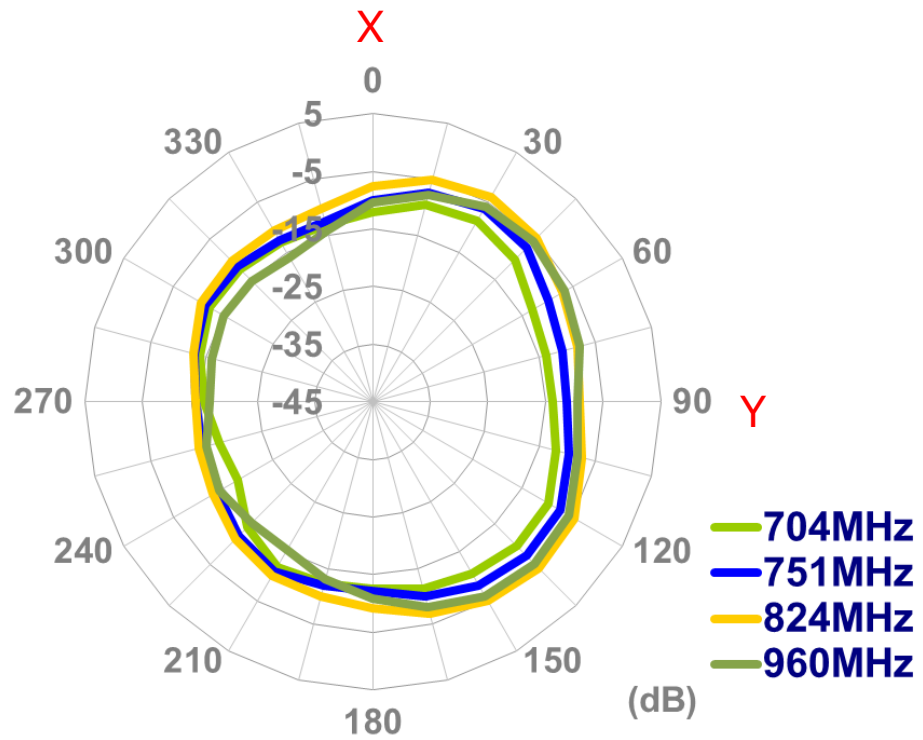

XY Plane

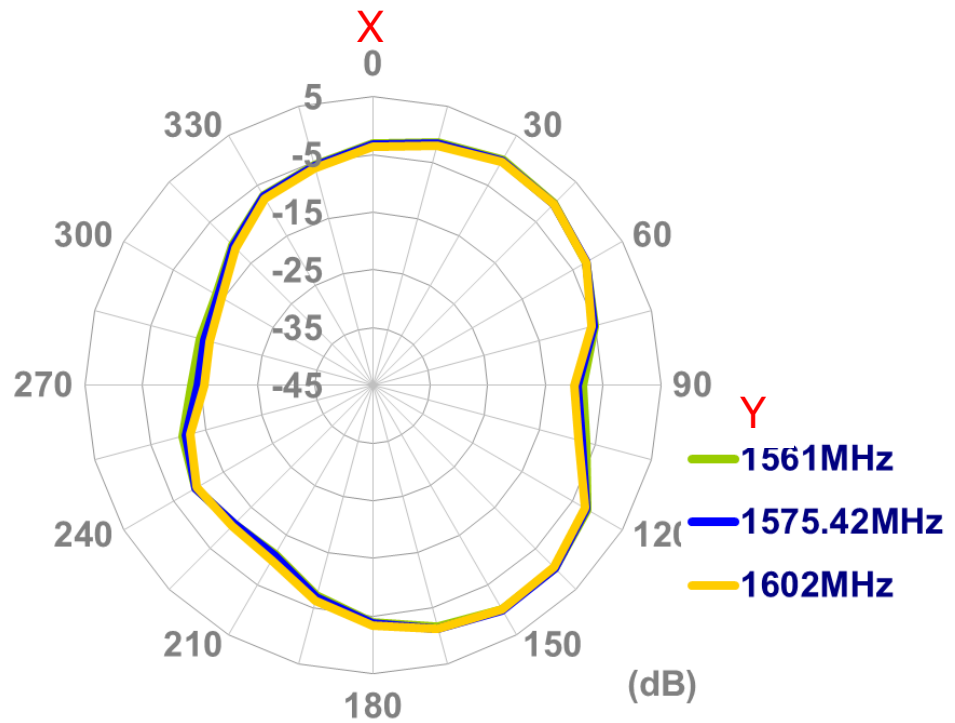

XY Plane

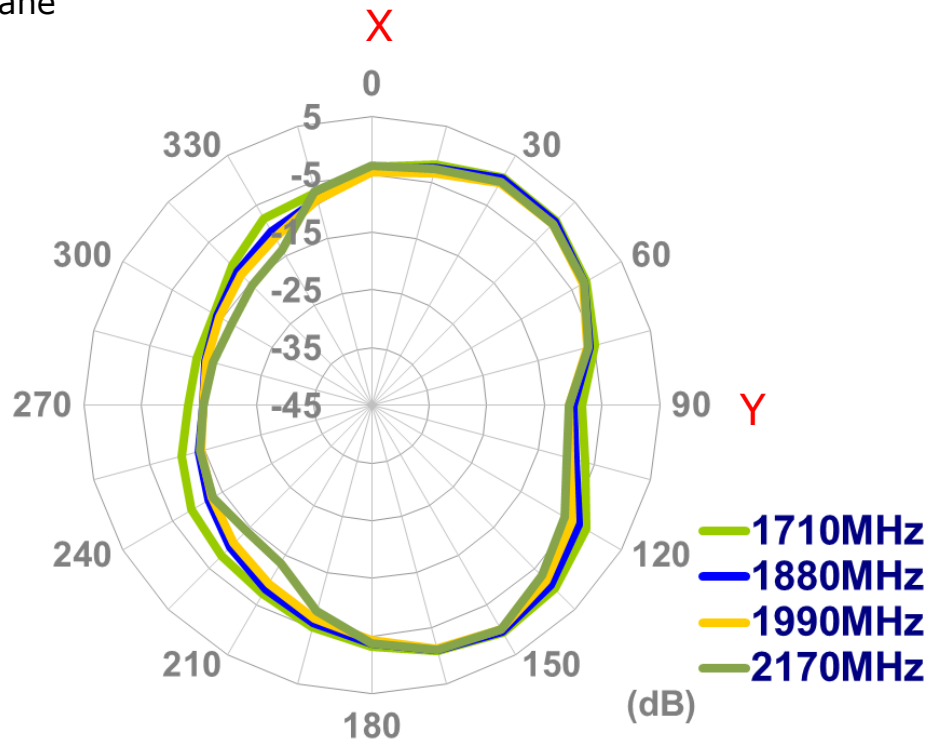

XY Plane

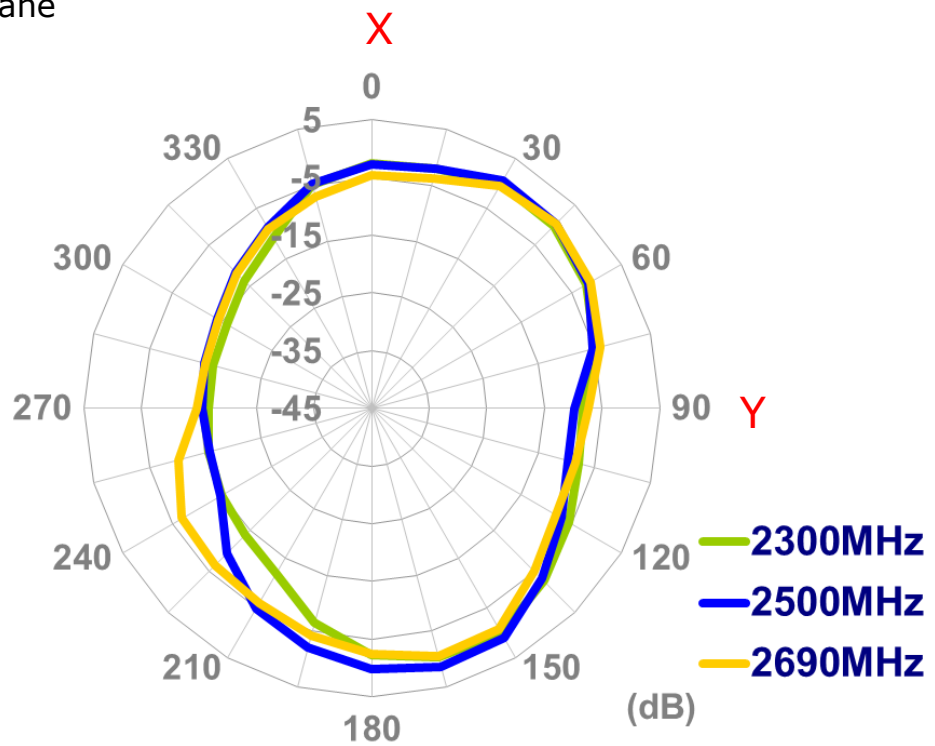

XZ Plane

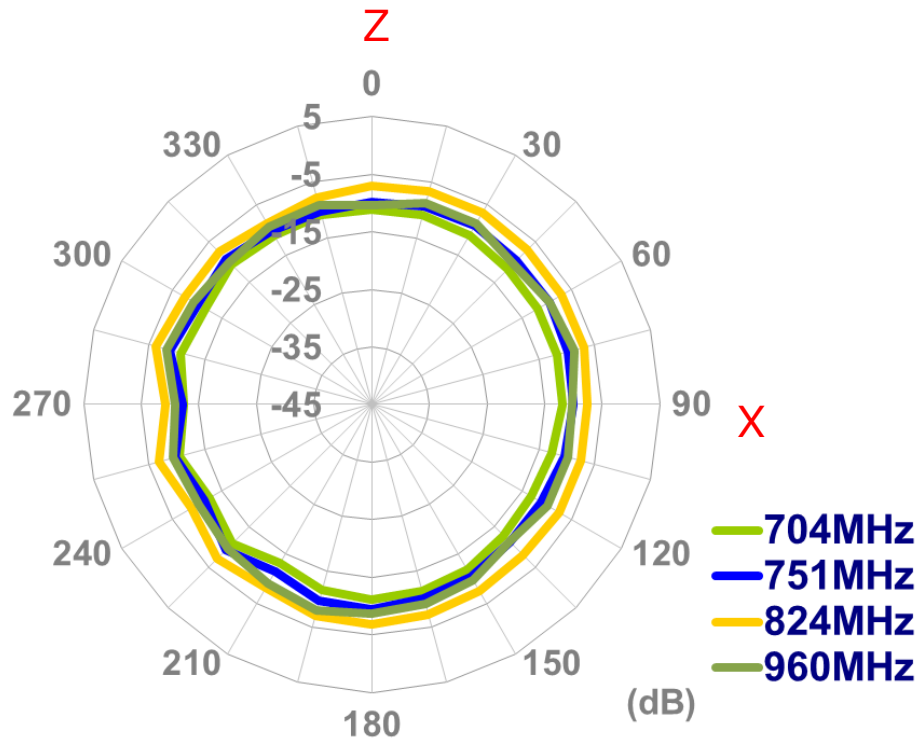

XZ Plane

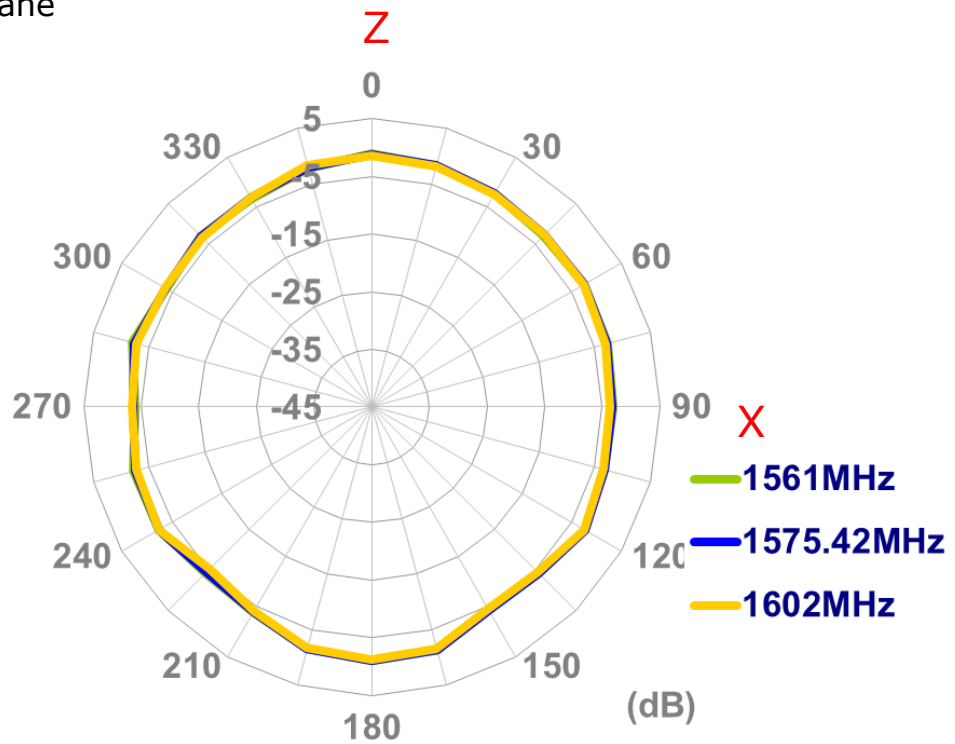

XZ Plane

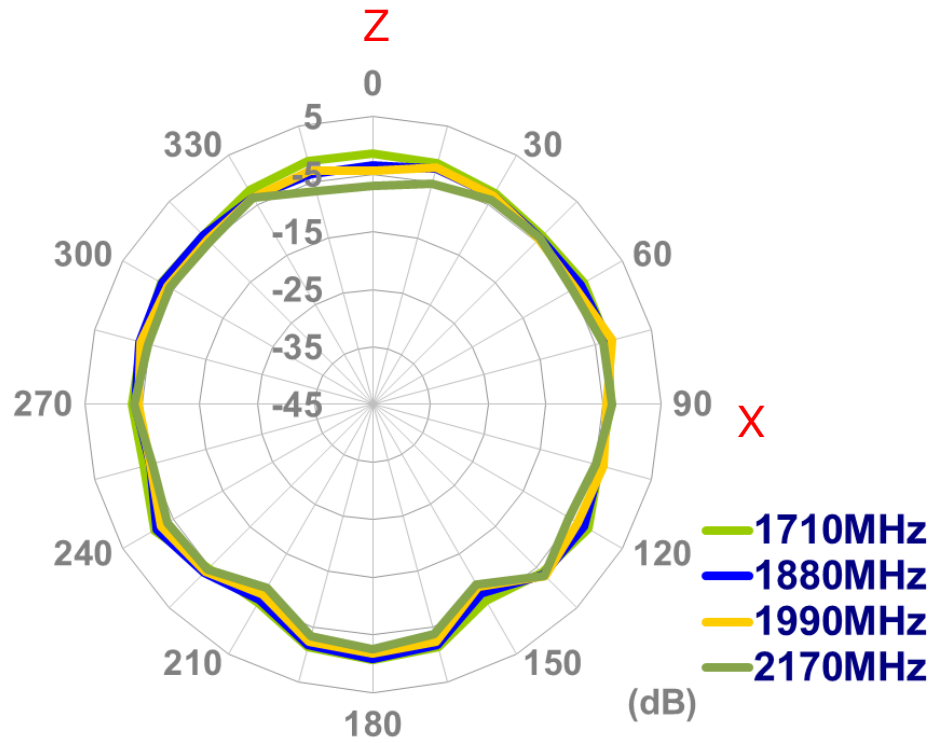

XZ Plane

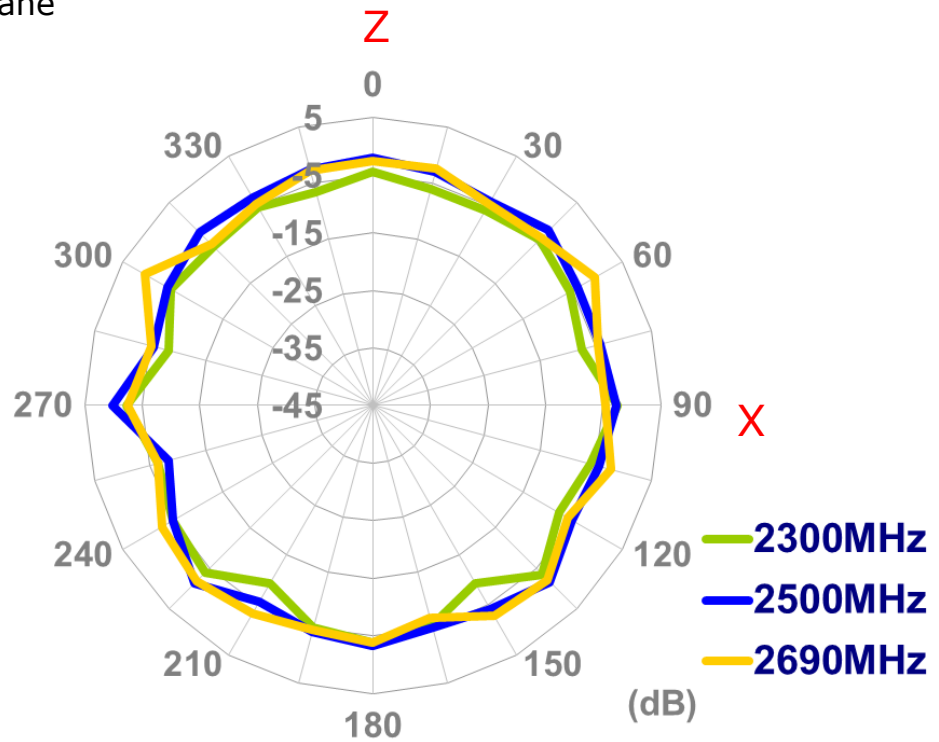

YZ Plane

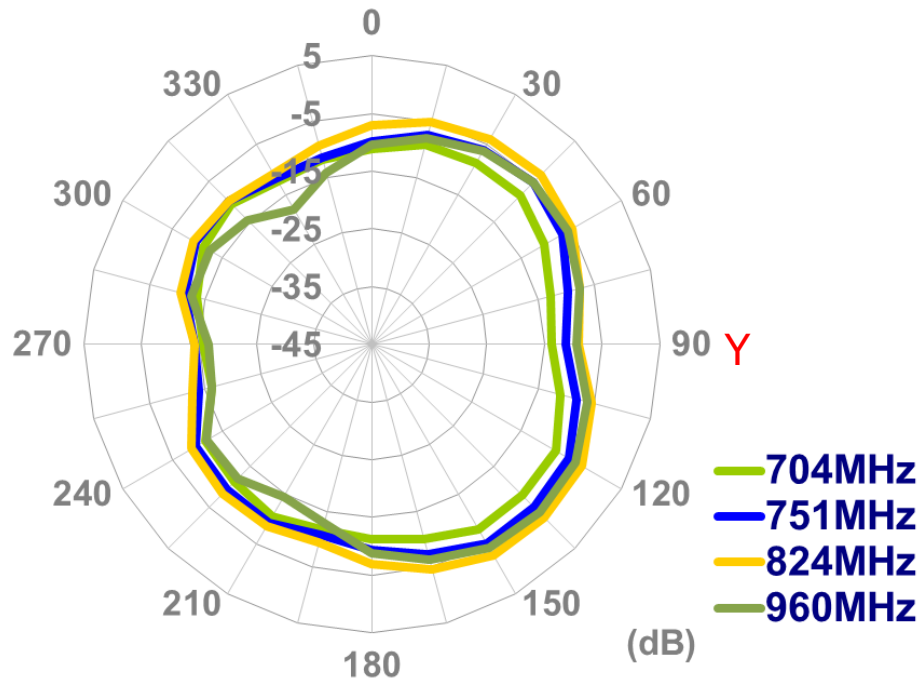

YZ Plane

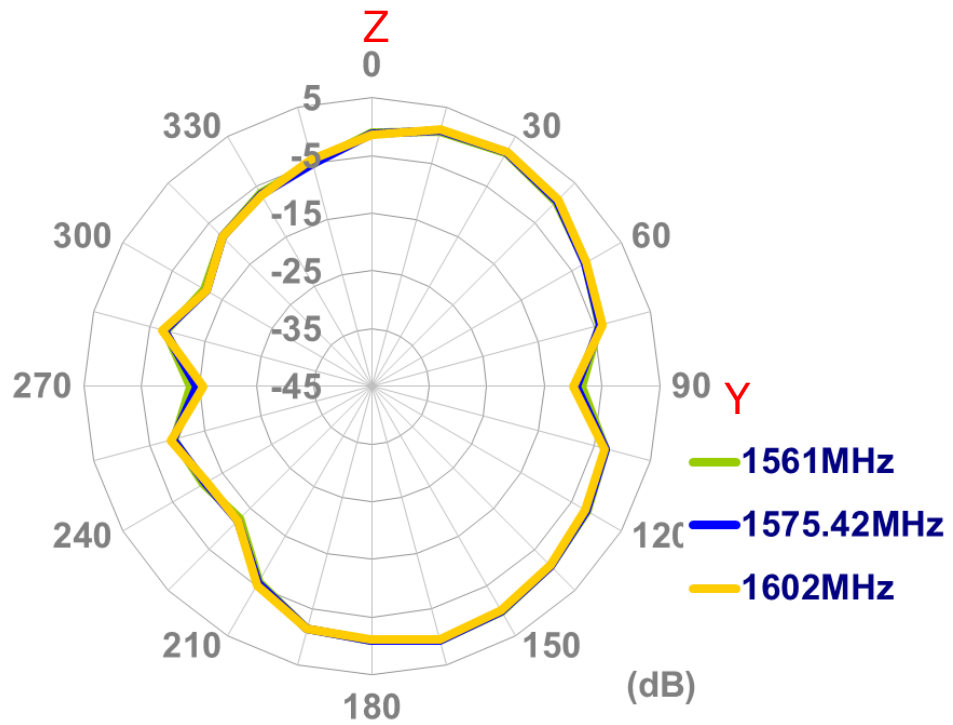

YZ Plane

Z

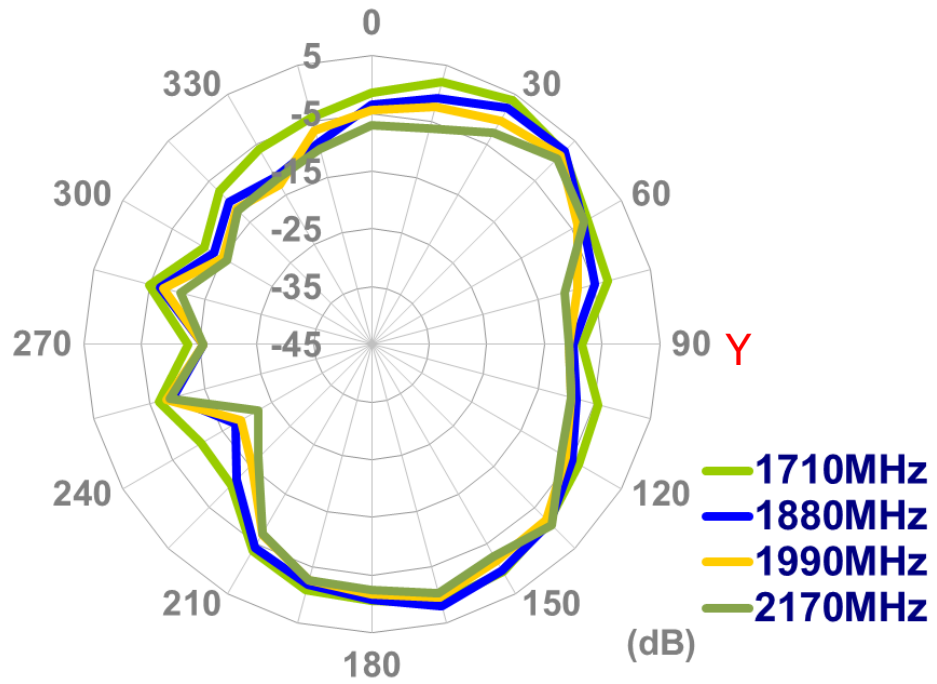

YZ Plane

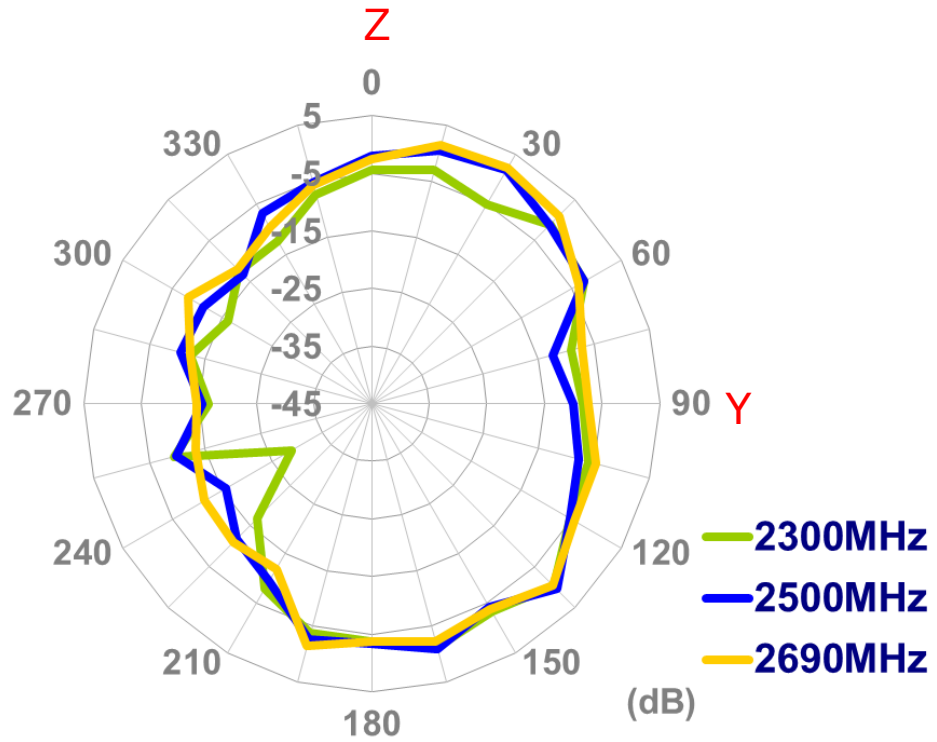

5. Installation

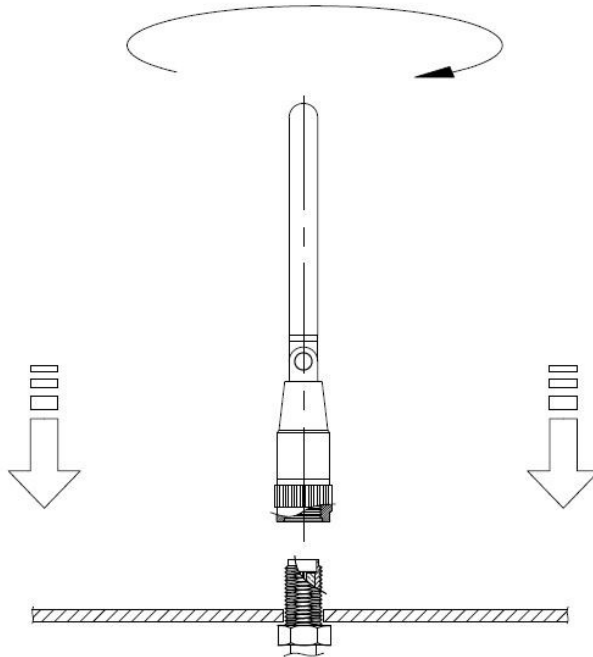

Recommended torque for mounting is 0.9 N.m
Maximum torque for mounting is 1.176 N.m

6. DRAWING

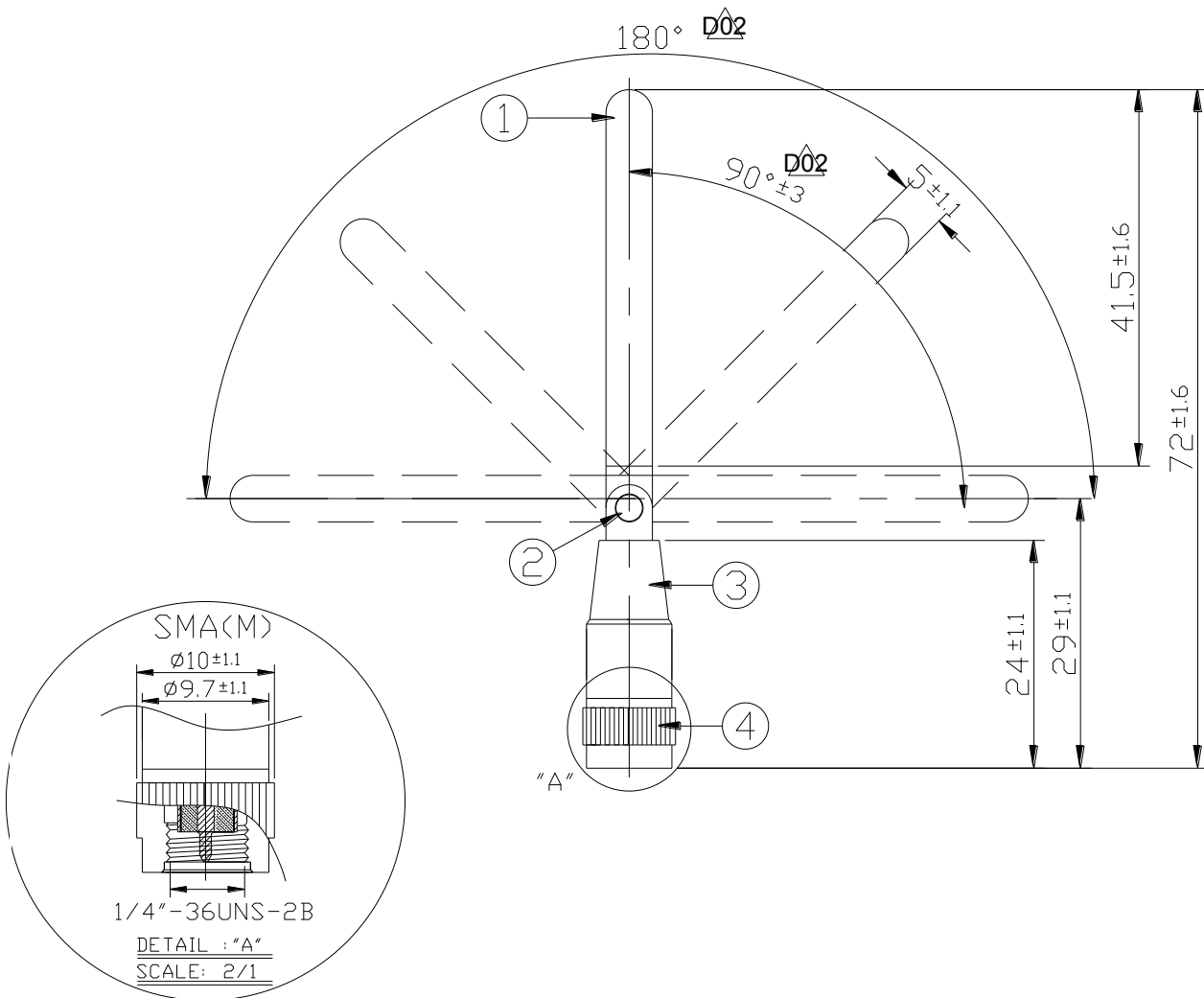

	Name	P/N	Material	Finish	QTY
1	Housing	001013F000002A	POM	Black	1
2	Hinge	000613F000002A	Brass	Ni Plated	1
3	Cap	000713G000002A	POM	Orange $\Delta 03$	1
4	SMA(M) ST	200213F000002A	Brass	Ni Plated	1

7. PACKAGING

