

LSF010x 1/2/8 Channel Bidirectional Multi-Voltage Level Translator for Open-Drain and Push-Pull Application

1 Features

- Provides Bidirectional Voltage Translation With No Direction Pin
- Supports Up to 100 MHz Up Translation and Greater Than 100 MHz Down Translation at $\leq 30\text{pF}$ Cap Load and Up To 40 MHz Up/Down Translation at 50 pF Cap Load
- Supports Hot Insertion
- Allow Bidirectional Voltage Level Translation Between
 - 0.95 V \leftrightarrow 1.8/2.5/3.3/5 V
 - 1.2 V \leftrightarrow 1.8/2.5/3.3/5 V
 - 1.8 V \leftrightarrow 2.5/3.3/5 V
 - 2.5 V \leftrightarrow 3.3/5 V
 - 3.3 V \leftrightarrow 5 V
- Low Standby Current
- 5 V Tolerance I/O Port to Support TTL
- Low Ron Provides Less Signal Distortion
- High-Impedance I/O pins For EN = Low
- Flow-Through Pinout for Ease PCB Trace Routing
- Latch-Up Performance Exceeds 100 mA Per JESD 17
- -40°C to 125°C Operating Temperature Range
- ESD Performance Tested Per JESD 22
 - 2000 V Human-Body Model (A114-B, Class II)
 - 200 V Machine Model (A115-A)
 - 1000 V Charged-Device Model (C101)

2 Applications

- GPIO, MDIO, PMBus, SMBus, SDIO, UART, I²C, and Other Interfaces in Telecom Infrastructure
- Industrial
- Automotive
- Personal Computing

3 Description

LSF family supports up to 100 MHz up translation and greater than 100 MHz down translation at $\leq 30\text{pF}$ cap load and up to 40 MHz up/down translation at 50 pF cap load which allows the LSF family to support more consumer or telecom interfaces (MDIO or SDIO). The LSF family has bidirectional voltage translation without the need for DIR pin which minimizes system effort (for PMBus, I²C, or SMBus).

LSF family supports 5 V tolerance on IO port which makes it compatible with TTL levels in industrial and telecom applications. The LSF family is able to set up different voltage translation levels on each channel which makes it very flexible.

Device Information⁽¹⁾

PART NUMBER	PACKAGE(PINS)	BODY SIZE (NOM)
LSF0101	SON (6)	1.45 mm x 1.00 mm
LSF0102	X2SON (8)	1.40 mm x 1.00 mm
	DSBGA (8)	1.90 mm x 1.00 mm
	SM8 (8)	2.80 mm x 2.95 mm
	VSSOP (8)	2.30 mm x 2.00 mm
LSF0108	VQFN (20)	4.50 mm x 2.50 mm
	TSSOP (20)	4.40 mm x 6.50 mm

(1) For all available packages, see the orderable addendum at the end of the data sheet.

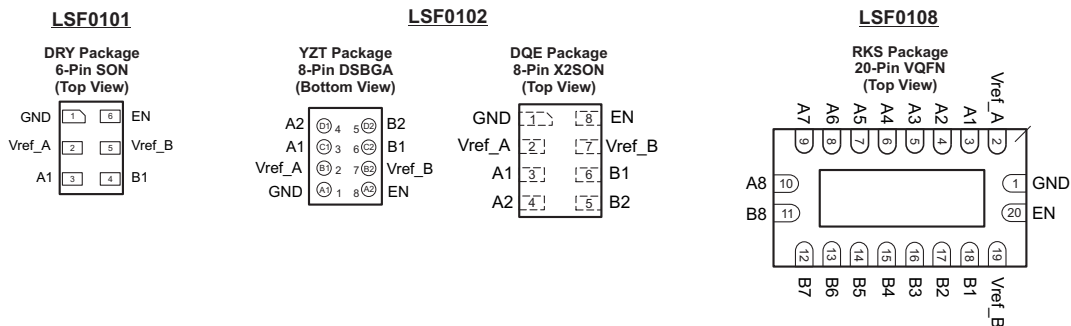

Table of Contents

1 Features	1	6.14 LSF0108 AC Performance (Translating Up) Switching Characteristics, $V_{GATE} = 2.5\text{ V}$	8
2 Applications	1	6.15 Typical Characteristics	8
3 Description	1	7 Parameter Measurement Information	9
4 Revision History	2	8 Detailed Description	10
5 Pin Configuration and Functions	3	8.1 Overview	10
6 Specifications	5	8.2 Functional Block Diagrams	10
6.1 Absolute Maximum Ratings	5	8.3 Feature Description	11
6.2 ESD Ratings	5	8.4 Device Functional Modes	11
6.3 Recommended Operating Conditions	5	9 Application and Implementation	12
6.4 Thermal Information: LSF0101, LSF0108	6	9.1 Application Information	12
6.5 Thermal Information: LSF0102	6	9.2 Typical Application	12
6.6 Electrical Characteristics	6	10 Power Supply Recommendations	19
6.7 LSF0101/02 AC Performance (Translating Down) Switching Characteristics, $V_{GATE} = 3.3\text{ V}$	7	11 Layout	19
6.8 LSF0108 AC Performance (Translating Down) Switching Characteristics, $V_{GATE} = 3.3\text{ V}$	7	11.1 Layout Guidelines	19
6.9 LSF0101/02 AC Performance (Translating Down) Switching Characteristics, $V_{GATE} = 2.5\text{ V}$	7	11.2 Layout Example	19
6.10 LSF0108 AC Performance (Translating Down) Switching Characteristics, $V_{GATE} = 2.5\text{ V}$	7	12 Device and Documentation Support	21
6.11 LSF0101/02 AC Performance (Translating Up) Switching Characteristics, $V_{GATE} = 3.3\text{ V}$	7	12.1 Related Links	21
6.12 LSF0108 AC Performance (Translating Up) Switching Characteristics, $V_{GATE} = 3.3\text{ V}$	7	12.2 Community Resources	21
6.13 LSF0101/02 AC Performance (Translating Up) Switching Characteristics, $V_{GATE} = 2.5\text{ V}$	8	12.3 Trademarks	21
		12.4 Electrostatic Discharge Caution	21
		12.5 Glossary	21
		13 Mechanical, Packaging, and Orderable Information	21

4 Revision History

NOTE: Page numbers for previous revisions may differ from page numbers in the current version.

Changes from Revision F (October 2015) to Revision G Page

- Added all available package dimensions in Device Information and changed the pin diagram description. 1

Changes from Revision E (July 2015) to Revision F Page

- Changed Features from "Supports High Speed Translation, Greater Than 100 MHz" to "Supports Up to 100 MHz Up Translation and Greater Than 100 MHz Down Translation at $\leq 30\text{pF}$ Cap Load and Up To 40 MHz Up/Down Translation at 50 pF Cap Load." 1
- Updated all propagation delay tables changed from generic to specific LSF devices. 7

Changes from Revision D (October 2014) to Revision E Page

- Deleted "Less Than 1.5 ns Max Propagation Delay" from Features. 1
- Updated ESD Ratings table. 5
- Increased MAX value for T_A , Operating free-air temperature, from 85°C to 125°C. 5

Changes from Revision C (May 2014) to Revision D Page

- Changed bidirectional voltage level translation from 1.0 to 0.95 1
- Changed YZT package to fix view error. 1
- Changed YZT package to fix view error. 3
- Added pin numbers to *Pin Functions* table. 4

- Added Vref_A footnote. 13

Changes from Revision B (May 2014) to Revision C **Page**

- Changed LSF0108 status from preview to production. 1
- Updated document title. 1
- Updated Handling Ratings table. 5

Changes from Revision A (January 2014) to Revision B **Page**

- Added LSF0108 to data sheet. 1

Changes from Original (December 2013) to Revision A **Page**

- Updated part number..... 1
- Updated *Electrical Characteristics* table..... 6

5 Pin Configuration and Functions

LSF0102 DCT or DCU Package
8-Pin SM8 or VSSOP
Top View

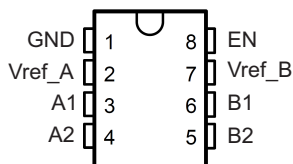

LSF0102 DQE Package
8-Pin X2SON
Top View

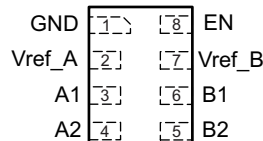

LSF0102 YZT Package
8-Pin DSBGA
Bottom View

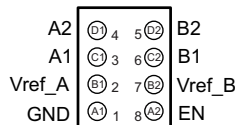

LSF0101 DRY Package
6-Pin SON
Top View

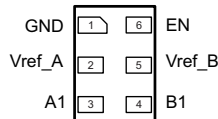

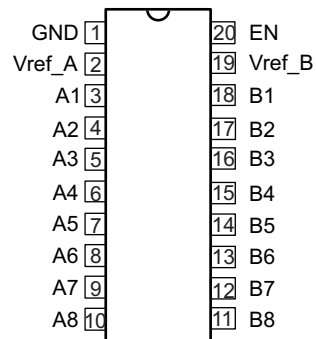
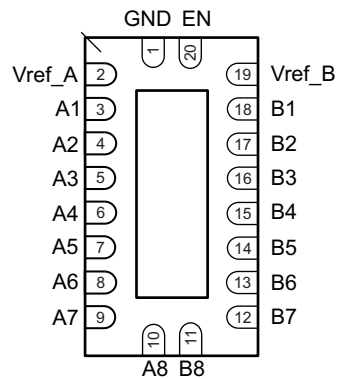
**LSF0108 PW Package
20-Pin TSSOP
Top View**

**LSF0108 RKS Package
20-Pin VQFN
Top View**

Pin Functions

NAME	PIN			DESCRIPTION
	DCT, DCU, DQE, YZT NO.	DRY NO.	PW or RKS NO.	
An	3, 4	3	3 to 10	Data port
Bn	6, 5	4	18 to 11	
EN	8	6	20	Switch enable input; connect to Vref_B and pull-up through a high resistor (200 kΩ).
GND	1	1	1	Ground
Vref_A	2	2	2	Reference supply voltage; see Application and Implementation .
Vref_B	7	5	19	Reference supply voltage; see Application and Implementation .

6 Specifications

6.1 Absolute Maximum Ratings⁽¹⁾

over operating free-air temperature (unless otherwise noted)

		MIN	MAX	UNIT
V_I	Input voltage ⁽²⁾	-0.5	7	V
$V_{I/O}$	Input/output voltage ⁽²⁾	-0.5	7	V
	Continuous channel current		128	mA
I_{IK}	Input clamp current	$V_I < 0$	-50	mA
$R_{\theta JA}$	Package thermal impedance ⁽³⁾	DCT package	220	°C/W
		DCU package	227	
T_{stg}	Storage temperature range	-65	150	°C

- (1) Stresses beyond those listed under "absolute maximum ratings" may cause permanent damage to the device. These are stress ratings only, and functional operation of the device at these or any other conditions beyond those indicated under "recommended operating conditions" is not implied. Exposure to absolute-maximum-rated conditions for extended periods may affect device reliability.
- (2) The input and input/output negative-voltage ratings may be exceeded if the input and input/output clamp-current ratings are observed.
- (3) The package thermal impedance is calculated in accordance with JESD 51-7.

6.2 ESD Ratings

		VALUE	UNIT
$V_{(ESD)}$	Electrostatic discharge	Human-body model (HBM), per ANSI/ESDA/JEDEC JS-001 ⁽¹⁾	±2000
		Charged-device model (CDM), per JEDEC specification JESD22-C101 ⁽²⁾	±1000

- (1) JEDEC document JEP155 states that 500-V HBM allows safe manufacturing with a standard ESD control process. Manufacturing with less than 500-V HBM is possible with the necessary precautions.
- (2) JEDEC document JEP157 states that 250-V CDM allows safe manufacturing with a standard ESD control process. Manufacturing with less than 250-V CDM is possible with the necessary precautions.

6.3 Recommended Operating Conditions

over operating free-air temperature range (unless otherwise noted)

		MIN	MAX	UNIT
$V_{I/O}$	Input/output voltage	0	5	V
$V_{ref_A/B/EN}$	Reference voltage	0	5	V
I_{PASS}	Pass transistor current		64	mA
T_A	Operating free-air temperature	-40	125	°C

6.4 Thermal Information: LSF0101, LSF0108

THERMAL METRIC ⁽¹⁾		LSF0101	LSF0108	LSF0108	UNIT
		DRY (SON)	RKS (VQFN)	PW (TSSOP)	
		6 PINS	20 PINS	20 PINS	
$R_{\theta JA}$	Junction-to-ambient thermal resistance	407.0	49.3	106.6	°C/W
$R_{\theta JC(top)}$	Junction-to-case (top) thermal resistance	285.2	45.9	41.0	°C/W
$R_{\theta JB}$	Junction-to-board thermal resistance	271.6	20.6	57.6	°C/W
Ψ_{JT}	Junction-to-top characterization parameter	113.5	2.5	4.2	°C/W
Ψ_{JB}	Junction-to-board characterization parameter	271.0	20.6	47.0	°C/W
$R_{\theta JC(bot)}$	Junction-to-case (bottom) thermal resistance	n/a	3.4	n/a	°C/W

(1) For more information about traditional and new thermal metrics, see the *IC Package Thermal Metrics* application report, [SPRA953](#).

6.5 Thermal Information: LSF0102

THERMAL METRIC ⁽¹⁾		LSF0102	LSF0102	LSF0102	LSF0102	UNIT
		DCU (US8)	DCT (SM8)	DQE (X2SON)	YZT (DSBGA)	
		8 PINS	8 PINS	8 PINS	8 PINS	
$R_{\theta JA}$	Junction-to-ambient thermal resistance	210.1	189.6	246.5	125.5	°C/W
$R_{\theta JC(top)}$	Junction-to-case (top) thermal resistance	89.1	119.6	149.1	1.0	°C/W
$R_{\theta JB}$	Junction-to-board thermal resistance	88.8	102.1	100.0	62.7	°C/W
Ψ_{JT}	Junction-to-top characterization parameter	8.3	44.5	17.1	3.4	°C/W
Ψ_{JB}	Junction-to-board characterization parameter	88.4	101.0	99.8	62.7	°C/W
$R_{\theta JC(bot)}$	Junction-to-case (bottom) thermal resistance	n/a	n/a	n/a	n/a	°C/W

(1) For more information about traditional and new thermal metrics, see the *IC Package Thermal Metrics* application report, [SPRA953](#).

6.6 Electrical Characteristics

over recommended operating free-air temperature range (unless otherwise noted)

PARAMETER	TEST CONDITIONS		MIN	TYP ⁽¹⁾	MAX	UNIT
V_{IK}	$I_I = -18 \text{ mA}$, $V_{EN} = 0$				-1.2	V
I_{IH}	$V_I = 5 \text{ V}$, $V_{EN} = 0$				5.0	μA
I_{CC}	$V_{ref_B} = V_{EN} = 5.5 \text{ V}$, $V_{ref_A} = 4.5 \text{ V}$ or 1 V , $I_O = 0$, $V_I = V_{CC}$ or GND			1		μA
$C_{I(ref_A/B/EN)}$	$V_I = 3 \text{ V}$ or 0			11		pF
$C_{io(off)}$	$V_O = 3 \text{ V}$ or 0 , $V_{EN} = 0$			4.0	6.0	pF
$C_{io(on)}$	$V_O = 3 \text{ V}$ or 0 , $V_{EN} = 3 \text{ V}$			10.5	12.5	pF
$r_{on}^{(2)}$	$V_I = 0$, $I_O = 64 \text{ mA}$	$V_{ref_A} = 3.3 \text{ V}$; $V_{ref_B} = V_{EN} = 5 \text{ V}$		8.0		Ω
		$V_{ref_A} = 1.8 \text{ V}$; $V_{ref_B} = V_{EN} = 5 \text{ V}$		9.0		
		$V_{ref_A} = 1.0 \text{ V}$; $V_{ref_B} = V_{EN} = 5 \text{ V}$		10		
	$V_I = 0$, $I_O = 32 \text{ mA}$	$V_{ref_A} = 1.8 \text{ V}$; $V_{ref_B} = V_{EN} = 5 \text{ V}$		10		Ω
		$V_{ref_A} = 2.5 \text{ V}$; $V_{ref_B} = V_{EN} = 5 \text{ V}$		15		
	$V_I = 1.8 \text{ V}$, $I_O = 15 \text{ mA}$	$V_{ref_A} = 3.3 \text{ V}$; $V_{ref_B} = V_{EN} = 5 \text{ V}$		9.0		Ω
	$V_I = 1.0 \text{ V}$, $I_O = 10 \text{ mA}$	$V_{ref_A} = 1.8 \text{ V}$; $V_{ref_B} = V_{EN} = 3.3 \text{ V}$		18		Ω
$V_I = 0 \text{ V}$, $I_O = 10 \text{ mA}$	$V_{ref_A} = 1.0 \text{ V}$; $V_{ref_B} = V_{EN} = 3.3 \text{ V}$		20		Ω	
$V_I = 0 \text{ V}$, $I_O = 10 \text{ mA}$	$V_{ref_A} = 1.0 \text{ V}$; $V_{ref_B} = V_{EN} = 1.8 \text{ V}$		30		Ω	

(1) All typical values are at $T_A = 25^\circ\text{C}$.

(2) Measured by the voltage drop between the A and B pins at the indicated current through the switch. On-state resistance is determined by the lowest voltage of the two (A or B) pins.

6.7 LSF0101/02 AC Performance (Translating Down) Switching Characteristics, $V_{GATE} = 3.3\text{ V}$

over recommended operating free-air temperature range, $V_{GATE} = 3.3\text{ V}$, $V_{IH} = 3.3\text{ V}$, $V_{IL} = 0$, and $V_M = 1.15\text{ V}$ (unless otherwise noted) (see [Figure 2](#))

PARAMETER	FROM (INPUT)	TO (OUTPUT)	$C_L = 50\text{ pF}$		$C_L = 30\text{ pF}$		$C_L = 15\text{ pF}$		UNIT
			TYP	MAX	TYP	MAX	TYP	MAX	
t_{PLH}	A or B	B or A	1.1		0.7		0.3		ns
t_{PHL}			1.2		0.8		0.4		

6.8 LSF0108 AC Performance (Translating Down) Switching Characteristics, $V_{GATE} = 3.3\text{ V}$

over recommended operating free-air temperature range, $V_{GATE} = 3.3\text{ V}$, $V_{IH} = 3.3\text{ V}$, $V_{IL} = 0$, and $V_M = 1.15\text{ V}$ (unless otherwise noted) (see [Figure 2](#))

PARAMETER	FROM (INPUT)	TO (OUTPUT)	$C_L = 50\text{ pF}$		$C_L = 30\text{ pF}$		$C_L = 15\text{ pF}$		UNIT
			TYP	MAX	TYP	MAX	TYP	MAX	
t_{PLH}	A or B	B or A	1.9		1.4		0.75		ns
t_{PHL}			2		1.5		0.85		

6.9 LSF0101/02 AC Performance (Translating Down) Switching Characteristics, $V_{GATE} = 2.5\text{ V}$

over recommended operating free-air temperature range, $V_{GATE} = 2.5\text{ V}$, $V_{IH} = 2.5\text{ V}$, $V_{IL} = 0$, and $V_M = 0.75\text{ V}$ (unless otherwise noted) (see [Figure 2](#))

PARAMETER	FROM (INPUT)	TO (OUTPUT)	$C_L = 50\text{ pF}$		$C_L = 30\text{ pF}$		$C_L = 15\text{ pF}$		UNIT
			TYP	MAX	TYP	MAX	TYP	MAX	
t_{PLH}	A or B	B or A	1.2		0.8		0.35		ns
t_{PHL}			1.3		1		0.5		

6.10 LSF0108 AC Performance (Translating Down) Switching Characteristics, $V_{GATE} = 2.5\text{ V}$

over recommended operating free-air temperature range, $V_{GATE} = 2.5\text{ V}$, $V_{IH} = 2.5\text{ V}$, $V_{IL} = 0$, and $V_M = 0.75\text{ V}$ (unless otherwise noted) (see [Figure 2](#))

PARAMETER	FROM (INPUT)	TO (OUTPUT)	$C_L = 50\text{ pF}$		$C_L = 30\text{ pF}$		$C_L = 15\text{ pF}$		UNIT
			TYP	MAX	TYP	MAX	TYP	MAX	
t_{PLH}	A or B	B or A	2		1.45		0.8		ns
t_{PHL}			2.1		1.55		0.9		

6.11 LSF0101/02 AC Performance (Translating Up) Switching Characteristics, $V_{GATE} = 3.3\text{ V}$

over recommended operating free-air temperature range, $V_{GATE} = 3.3\text{ V}$, $V_{IH} = 2.3\text{ V}$, $V_{IL} = 0$, $V_T = 3.3\text{ V}$, $V_M = 1.15\text{ V}$ and $R_L = 300$ (unless otherwise noted) (see [Figure 2](#))

PARAMETER	FROM (INPUT)	TO (OUTPUT)	$C_L = 50\text{ pF}$		$C_L = 30\text{ pF}$		$C_L = 15\text{ pF}$		UNIT
			TYP	MAX	TYP	MAX	TYP	MAX	
t_{PLH}	A or B	B or A	1		0.8		0.4		ns
t_{PHL}			1		0.9		0.4		

6.12 LSF0108 AC Performance (Translating Up) Switching Characteristics, $V_{GATE} = 3.3\text{ V}$

over recommended operating free-air temperature range, $V_{GATE} = 3.3\text{ V}$, $V_{IH} = 2.3\text{ V}$, $V_{IL} = 0$, $V_T = 3.3\text{ V}$, $V_M = 1.15\text{ V}$ and $R_L = 300$ (unless otherwise noted) (see [Figure 2](#))

PARAMETER	FROM (INPUT)	TO (OUTPUT)	$C_L = 50\text{ pF}$		$C_L = 30\text{ pF}$		$C_L = 15\text{ pF}$		UNIT
			TYP	MAX	TYP	MAX	TYP	MAX	
t_{PLH}	A or B	B or A	2.1		1.55		0.9		ns
t_{PHL}			2.2		1.65		1		

LSF0101, LSF0102, LSF0108

SDLS966G – DECEMBER 2013 – REVISED FEBRUARY 2016

www.ti.com

6.13 LSF0101/02 AC Performance (Translating Up) Switching Characteristics, $V_{GATE} = 2.5\text{ V}$

over recommended operating free-air temperature range, $V_{GATE} = 2.5\text{ V}$, $V_{IH} = 1.5\text{ V}$, $V_{IL} = 0$, $V_T = 2.5\text{ V}$, $V_M = 0.75\text{ V}$ and $R_L = 300$ (unless otherwise noted) (see [Figure 2](#))

PARAMETER	FROM (INPUT)	TO (OUTPUT)	$C_L = 50\text{ pF}$		$C_L = 30\text{ pF}$		$C_L = 15\text{ pF}$		UNIT
			TYP	MAX	TYP	MAX	TYP	MAX	
t_{PLH}	A or B	B or A	1.1		0.9		0.45		ns
t_{PHL}			1.3		1.1		0.6		

6.14 LSF0108 AC Performance (Translating Up) Switching Characteristics, $V_{GATE} = 2.5\text{ V}$

over recommended operating free-air temperature range, $V_{GATE} = 2.5\text{ V}$, $V_{IH} = 1.5\text{ V}$, $V_{IL} = 0$, $V_T = 2.5\text{ V}$, $V_M = 0.75\text{ V}$ and $R_L = 300$ (unless otherwise noted) (see [Figure 2](#))

PARAMETER	FROM (INPUT)	TO (OUTPUT)	$C_L = 50\text{ pF}$		$C_L = 30\text{ pF}$		$C_L = 15\text{ pF}$		UNIT
			TYP	MAX	TYP	MAX	TYP	MAX	
t_{PLH}	A or B	B or A	1.8		1.35		0.8		ns
t_{PHL}			1.9		1.45		0.9		

6.15 Typical Characteristics

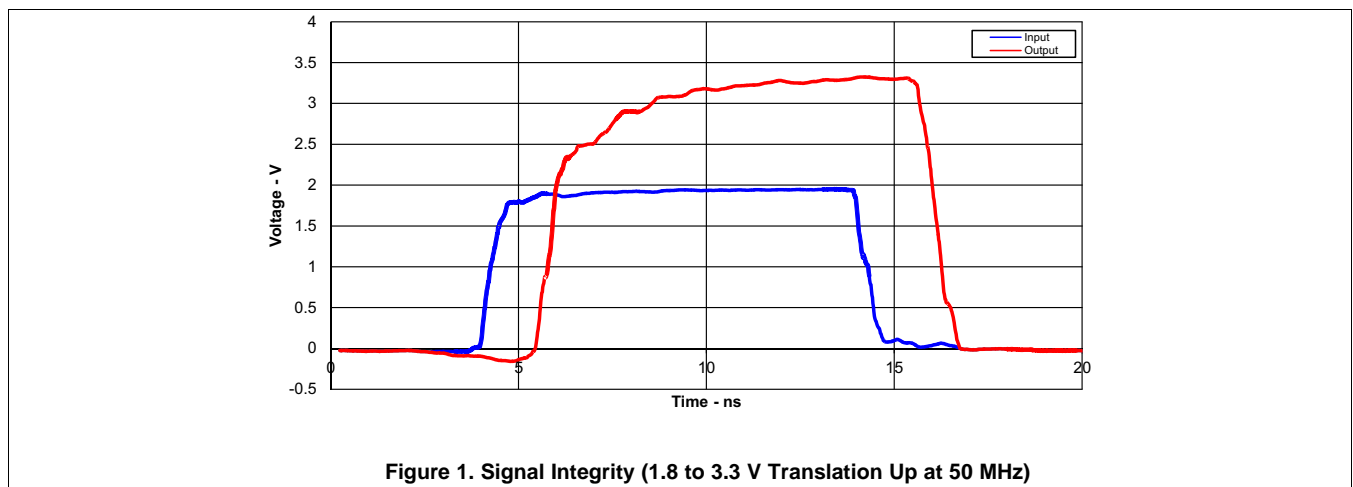
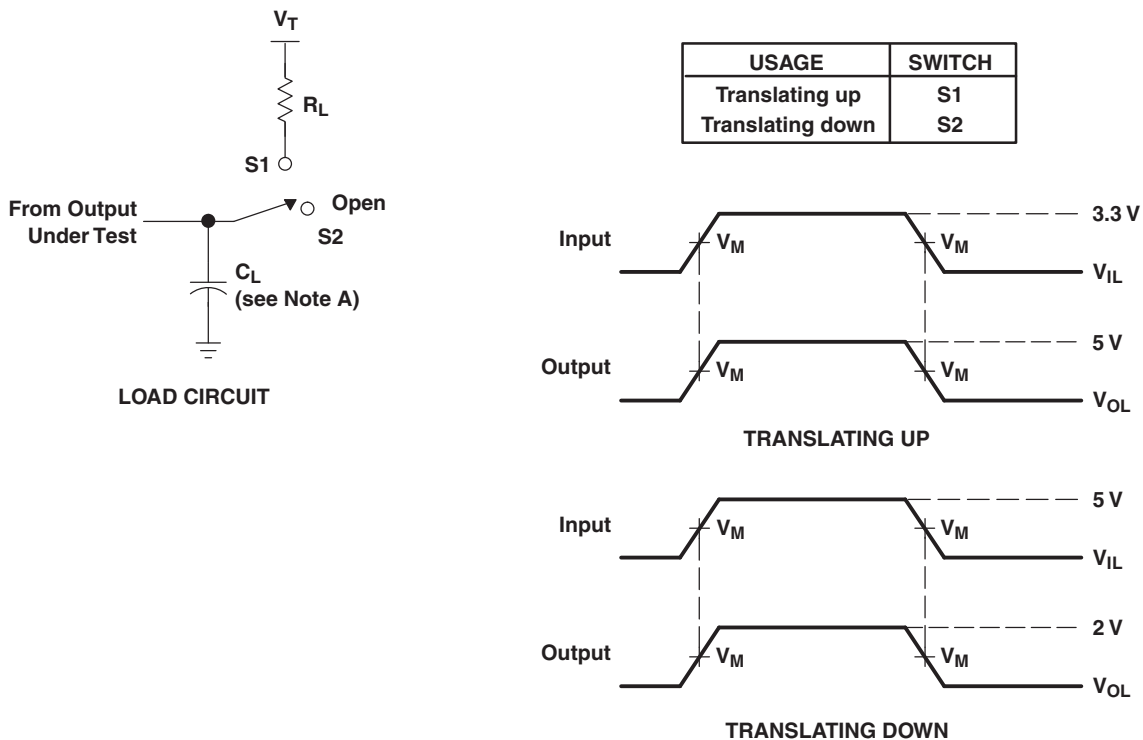

Figure 1. Signal Integrity (1.8 to 3.3 V Translation Up at 50 MHz)

7 Parameter Measurement Information



- NOTES: A. C_L includes probe and jig capacitance.
 B. All input pulses are supplied by generators having the following characteristics: PRR \leq 10 MHz, $Z_0 = 50 \Omega$, $t_r \leq 2$ ns, $t_f \leq 2$ ns.
 C. The outputs are measured one at a time, with one transition per measurement.

Figure 2. Load Circuit for Outputs

8 Detailed Description

8.1 Overview

The LSF family can be used in level translation applications for interfacing devices or systems operating at different interface voltages with one another. The LSF family is ideal for use in applications where an open-drain driver is connected to the data I/Os. With appropriate pull-up resistors and layout, LSF can achieve 100 MHz. The LSF family can also be used in applications where a push-pull driver is connected to the data I/Os.

8.2 Functional Block Diagrams

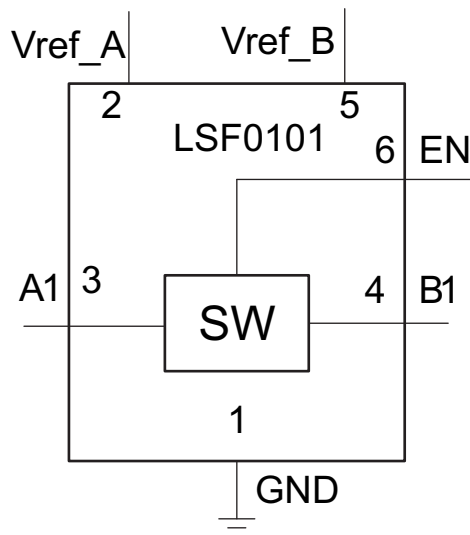

Figure 3. LSF0101 Functional Block Diagram

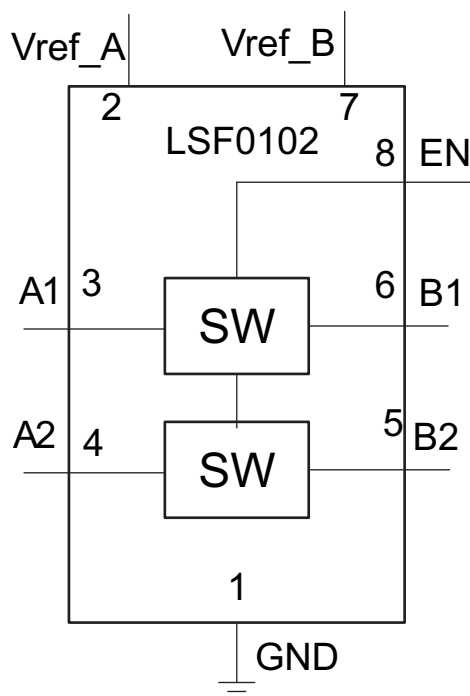

Figure 4. LSF0102 Functional Block Diagram

Functional Block Diagrams (continued)

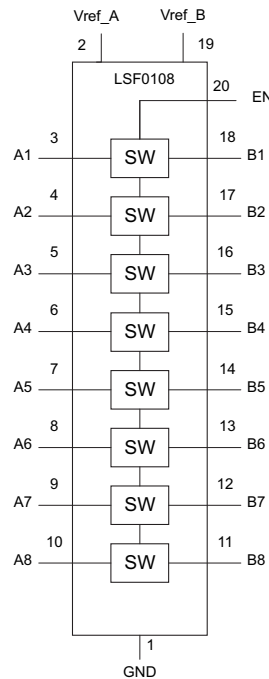

Figure 5. LSF0108 Functional Block Diagram

8.3 Feature Description

The LSF family are bidirectional voltage level translators operational from 0.95 to 4.5 V (Vref_A) and 1.8 to 5.5 V (Vref_B). This allows bidirectional voltage translations between 1 V and 5 V without the need for a direction pin in open-drain or push-pull applications. LSF family supports level translation applications with transmission speeds greater than 100 Mbps for open-drain systems using a 30-pF capacitance and 250-Ω pullup resistor.

When the An or Bn port is LOW, the switch is in the ON-state and a low resistance connection exists between the An and Bn ports. The low R_{on} of the switch allows connections to be made with minimal propagation delay and signal distortion. Assuming the higher voltage is on the Bn port when the Bn port is HIGH, the voltage on the An port is limited to the voltage set by Vref_A. When the An port is HIGH, the Bn port is pulled to the drain pull-up supply voltage ($V_{pu\#}$) by the pull-up resistors. This functionality allows a seamless translation between higher and lower voltages selected by the user without the need for directional control.

The supply voltage ($V_{pu\#}$) for each channel can be individually set up with a pull-up resistor. For example, CH1 can be used in up-translation mode (1.2 V ↔ 3.3 V) and CH2 in down-translation mode (2.5 V ↔ 1.8 V).

When EN is HIGH, the translator switch is on, and the An I/O is connected to the Bn I/O, respectively, allowing bidirectional data flow between ports. When EN is LOW, the translator switch is off, and a high-impedance state exists between ports. The EN input circuit is designed to be supplied by Vref_B. To ensure the high-impedance state during power-up or power-down, EN must be LOW.

8.4 Device Functional Modes

Table 1 expresses the functional modes of the LSF devices.

Table 1. Function Table

INPUT EN ⁽¹⁾ PIN	FUNCTION
H	An = Bn
L	H-Z

(1) EN is controlled by Vref_B logic levels and should be at least 1 V higher than Vref_A for best translator.

9 Application and Implementation

NOTE

Information in the following applications sections is not part of the TI component specification, and TI does not warrant its accuracy or completeness. TI's customers are responsible for determining suitability of components for their purposes. Customers should validate and test their design implementation to confirm system functionality.

9.1 Application Information

The LSF devices are able to perform voltage translation for open-drain or push-pull interface. [Table 2](#) provides some consumer/telecom interfaces as reference in regards to the different channel numbers that are supported by the LSF family.

Table 2. Voltage Translator for Consumer/Telecom Interface

Part Name	Channel Number	Interface
LSF0101	1	GPIO
LSF0102	2	GPIO, MDIO, SMBus, PMBus, I ² C
LSF0108	8	GPIO, MDIO, SDIO, SVID, UART, SMBus, PMBus, I ² C, SPI

9.2 Typical Application

9.2.1 I²C PMBus, SMBus, GPIO

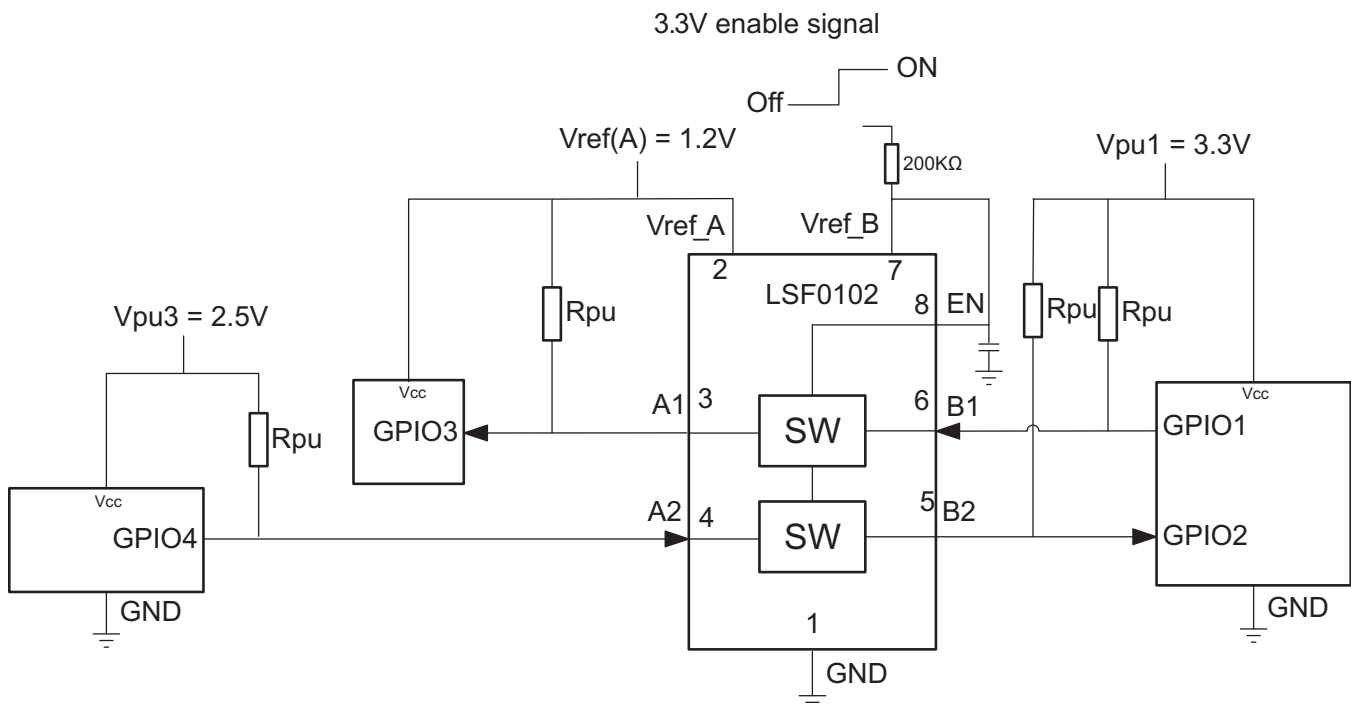

Figure 6. Bidirectional Translation to Multiple Voltage Levels

9.2.1.1 Design Requirements

9.2.1.1.1 Enable, Disable, and Reference Voltage Guidelines

The LSF family has an EN input that is used to disable the device by setting EN LOW, which places all I/Os in the high-impedance state. Since LSF family is switch-type voltage translator, the power consumption is very low. It is recommended to always enable LSF family for bidirectional application (I²C, SMBus, PMBus, or MDIO).

Typical Application (continued)

Table 3. Application Operating Condition

PARAMETER		MIN	TYP	MAX	UNIT
Vref_A ⁽¹⁾	reference voltage (A)	0.95		4.5	V
Vref_B	reference voltage (B)	Vref_A + 0.8		5.5	V
V _{I(EN)}	input voltage on EN pin	Vref_A + 0.8		5.5	V
V _{pu}	pull-up supply voltage	0		Vref_B	V

(1) Vref_A have to be the lowest voltage level across all of inputs and outputs.

The 200 kΩ, pull-up resistor is required to allow Vref_B to regulate the EN input. A filter capacitor on Vref_B is recommended. Also Vref_B and V_{I(EN)} are recommended to be at 1.0 V higher than Vref_A for best signal integrity.

9.2.1.2 Detailed Design Procedure

9.2.1.2.1 Bidirectional Translation

For the bidirectional clamping configuration (higher voltage to lower voltage or lower voltage to higher voltage), the EN input must be connected to Vref_B and both pins pulled to HIGH side V_{pu} through a pull-up resistor (typically 200 kΩ). This allows Vref_B to regulate the EN input. A filter capacitor on Vref_B is recommended. The master output driver can be push-pull or open-drain (pull-up resistors may be required) and the slave device output can be push-pull or open-drain (pull-up resistors are required to pull the Bn outputs to V_{pu}).

If either output is push-pull, data must be unidirectional or the outputs must be tri-state and be controlled by some direction-control mechanism to prevent HIGH-to-LOW contentions in either direction. If both outputs are open-drain, no direction control is needed.

In [Figure 6](#), the reference supply voltage (Vref_A) is connected to the processor core power supply voltage. When Vref_B is connected through a 200 kΩ resistor to a 3.3 V V_{pu} power supply, and Vref_A is set 1.0 V. The output of A3 and B4 has a maximum output voltage equal to Vref_A, and the bidirectional interface (Ch1/2, MDIO) has a maximum output voltage equal to V_{pu}.

9.2.1.2.2 Pull-up Resistor Sizing

The pull-up resistor value needs to limit the current through the pass transistor when it is in the ON state to about 15 mA. This ensures a pass voltage of 260 mV to 350 mV. If the current through the pass transistor is higher than 15 mA, the pass voltage also is higher in the ON state. To set the current through each pass transistor at 15 mA, to calculate the pull-up resistor value use the following equation:

$$R_{pu} = (V_{pu} - 0.35 \text{ V}) / 0.015 \text{ A} \quad (1)$$

[Table 4](#) summarizes resistor values, reference voltages, and currents at 15 mA, 10 mA, and 3 mA. The resistor value shown in the +10% column (or a larger value) should be used to ensure that the pass voltage of the transistor is 350 mV or less. The external driver must be able to sink the total current from the resistors on both sides of the LSF family device at 0.175 V, although the 15 mA applies only to current flowing through the LSF family device.

Table 4. Pull-up Resistor Values⁽¹⁾⁽²⁾

V _{DPU}	15 mA		10 mA		3 mA	
	NOMINAL (Ω)	+10% ⁽³⁾ (Ω)	NOMINAL (Ω)	+10% ⁽³⁾ (Ω)	NOMINAL (Ω)	+10% ⁽³⁾ (Ω)
5 V	310	341	465	512	1550	1705
3.3 V	197	217	295	325	983	1082
2.5 V	143	158	215	237	717	788
1.8 V	97	106	145	160	483	532
1.5 V	77	85	115	127	383	422
1.2 V	57	63	85	94	283	312

(1) Calculated for V_{OL} = 0.35 V

(2) Assumes output driver V_{OL} = 0.175 V at stated current

(3) +10% to compensate for V_{DD} range and resistor tolerance

9.2.1.2.3 LSF Family Bandwidth

The maximum frequency of the LSF family is dependent on the application. The device can operate at speeds of >100 MHz given the correct conditions. The maximum frequency is dependent upon the loading of the application. The LSF family behaves like a standard switch where the bandwidth of the device is dictated by the on resistance and on capacitance of the device.

Figure 7 shows a bandwidth measurement of the LSF family using a two-port network analyzer.

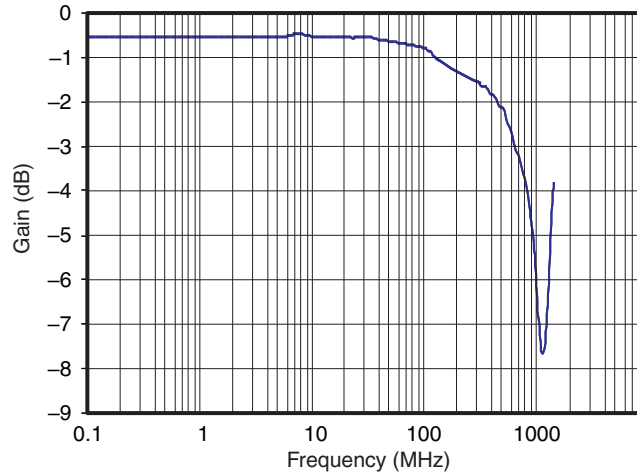

Figure 7. 3-dB Bandwidth

The 3-dB point of the LSF family is ≈ 600 MHz; however, this measurement is an analog type of measurement. For digital applications the signal should not degrade up to the fifth harmonic of the digital signal. The frequency bandwidth should be at least five times the maximum digital clock rate. This component of the signal is very important in determining the overall shape of the digital signal. In the case of the LSF family, a digital clock frequency of greater than 100 MHz can be achieved.

The LSF family does not provide any drive capability. Therefore higher frequency applications will require higher drive strength from the host side. No pull-up resistor is needed on the host side (3.3 V) if the LSF family is being driven by standard CMOS totem pole output driver. Ideally, it is best to minimize the trace length from the LSF family on the sink side (1.8 V) to minimize signal degradation.

All fast edges have an infinite spectrum of frequency components; however, there is an inflection (or knee) in the frequency spectrum of fast edges where frequency components higher than f_{knee} are insignificant in determining the shape of the signal.

To calculate the maximum practical frequency component, or the knee frequency (f_{knee}), use the following equations:

$$f_{knee} = 0.5 / RT \text{ (10 – 80\%)} \tag{2}$$

$$f_{knee} = 0.4 / RT \text{ (20 – 80\%)} \tag{3}$$

For signals with rise time characteristics based on 10% to 90% thresholds, f_{knee} is equal to 0.5 divided by the rise time of the signal. For signals with rise time characteristics based on 20% to 80% thresholds, which is very common in many of today's device specifications, f_{knee} is equal to 0.4 divided by the rise time of the signal.

Some guidelines to follow that will help maximize the performance of the device:

- Keep trace length to a minimum by placing the LSF family close to the I²C output of the processor.
- The trace length should be less than half the time of flight to reduce ringing and line reflections or non-monotonic behavior in the switching region.
- To reduce overshoots, a pull-up resistor can be added on the 1.8 V side; be aware that a slower fall time is to be expected.

9.2.1.3 Application Curve

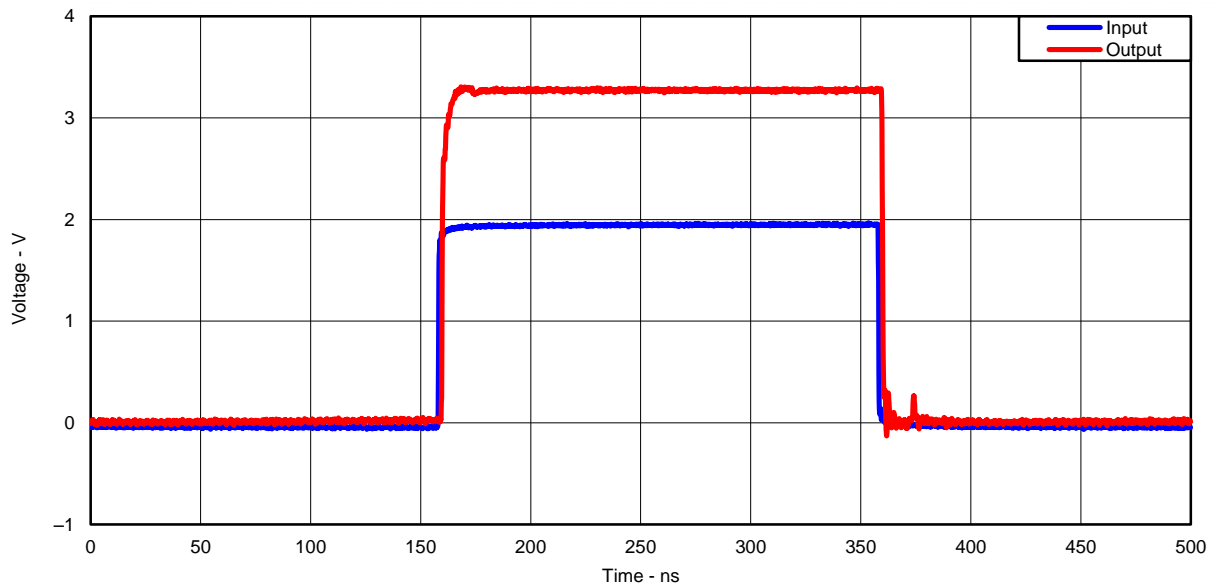

Figure 8. Captured Waveform From Above I²C Set-Up (1.8 V to 3.3 V at 2.5 MHz)

9.2.2 MDIO

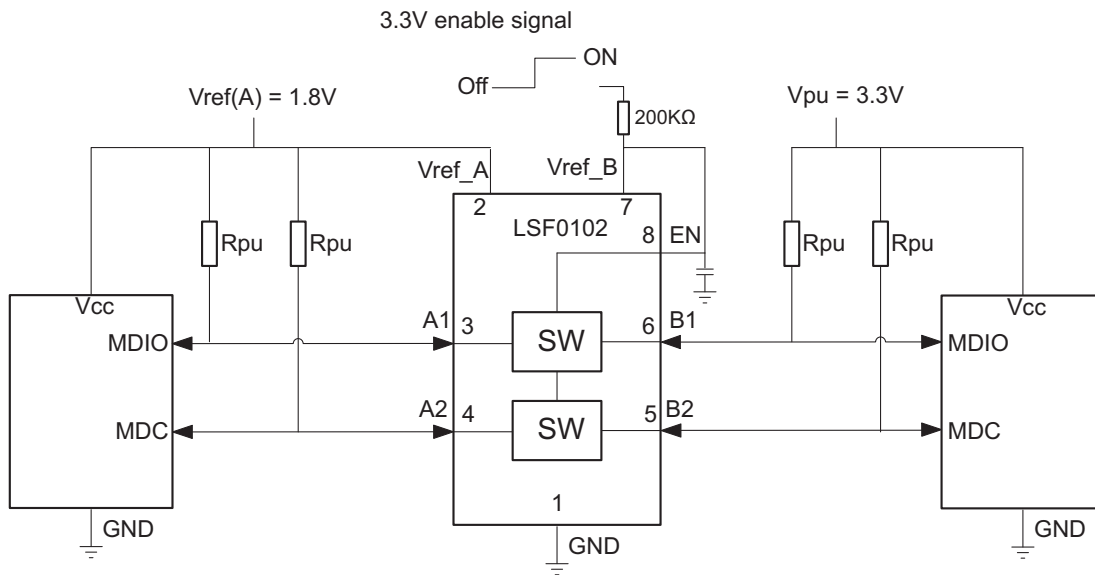

Figure 9. Typical Application Circuit (MDIO/Bidirectional Interface)

9.2.2.1 Design Requirements

Refer to [Design Requirements](#).

9.2.2.2 Detailed Design Procedure

Refer to [Detailed Design Procedure](#).

9.2.2.3 Application Curve

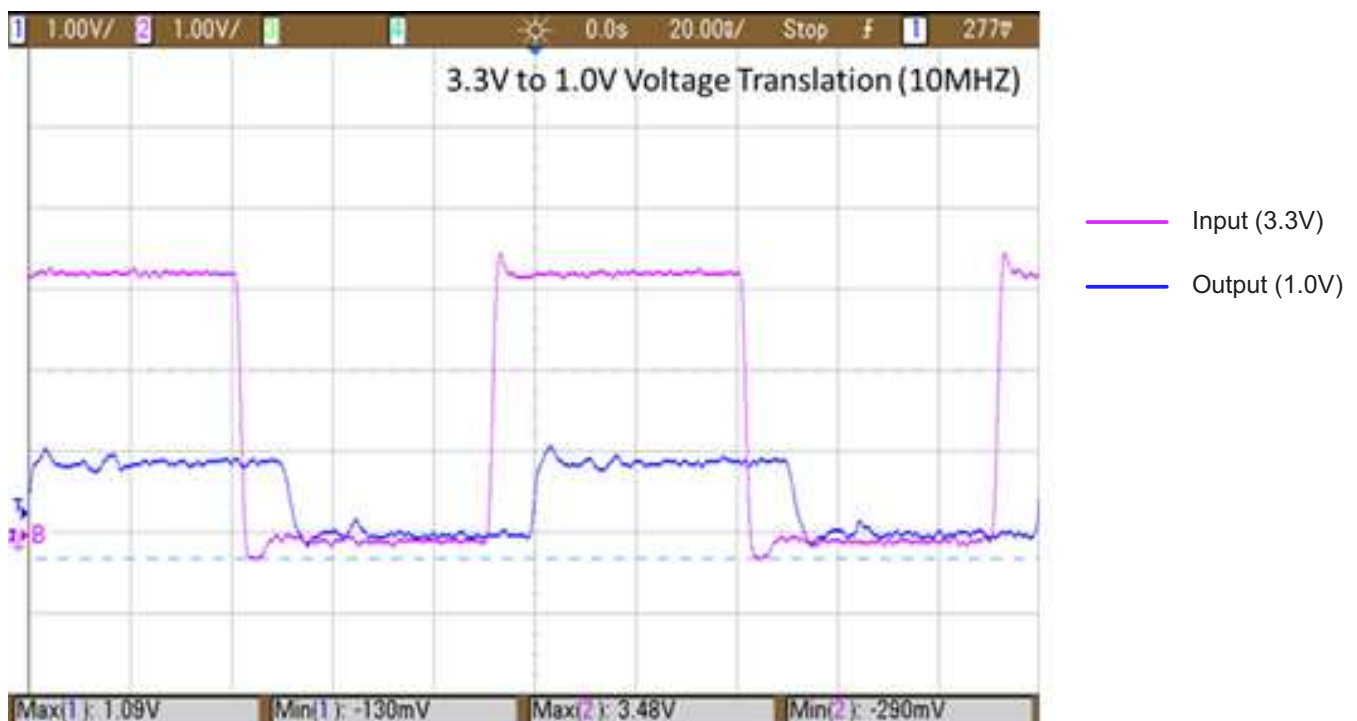
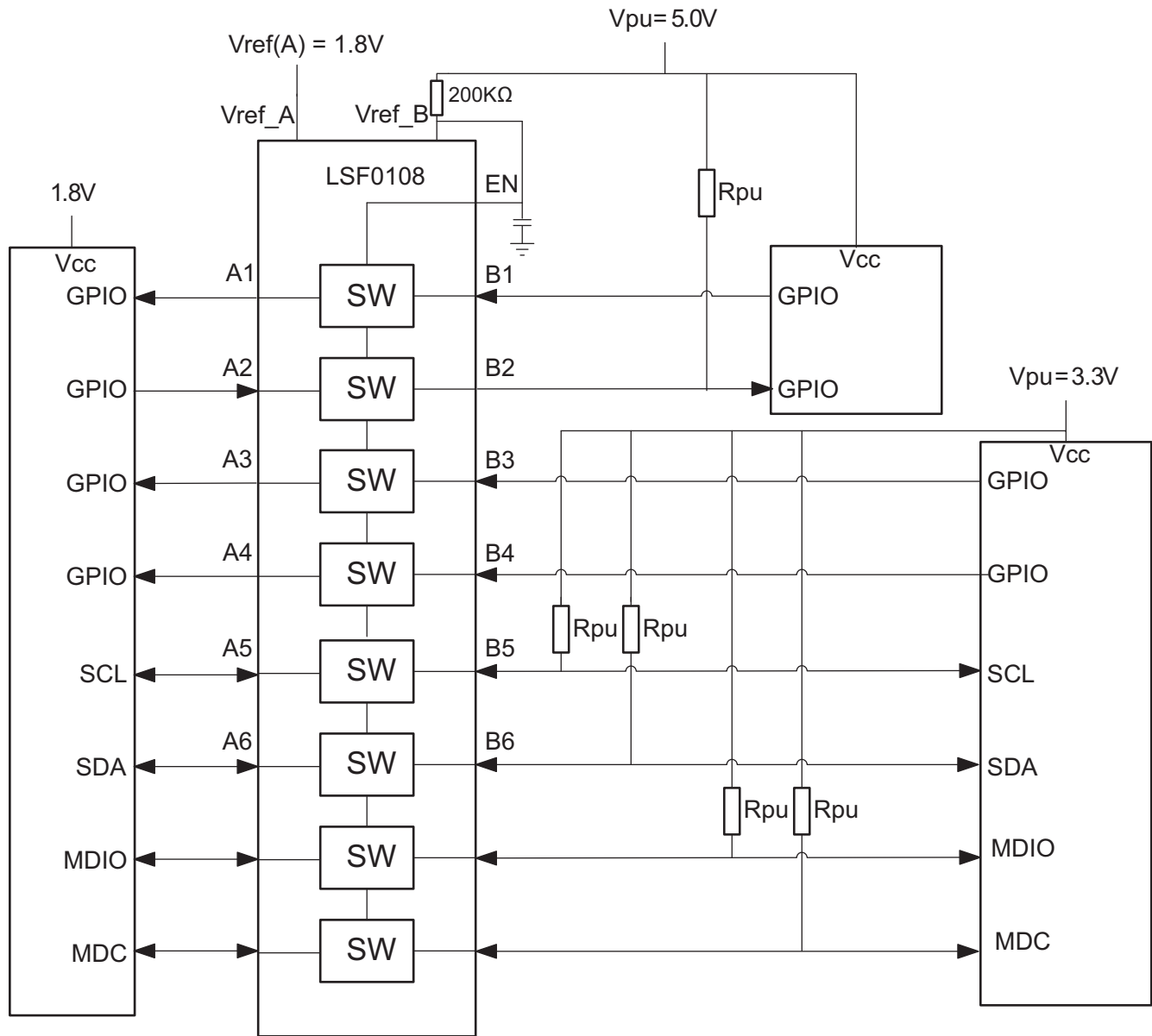

Figure 10. Captured Waveform From Above MDIO Setup

9.2.3 Multiple Voltage Translation in Single Device



9.2.3.1 Design Requirements

Refer to [Design Requirements](#).

9.2.3.2 Detailed Design Procedure

Refer to [Detailed Design Procedure](#).

9.2.3.3 Application Curve

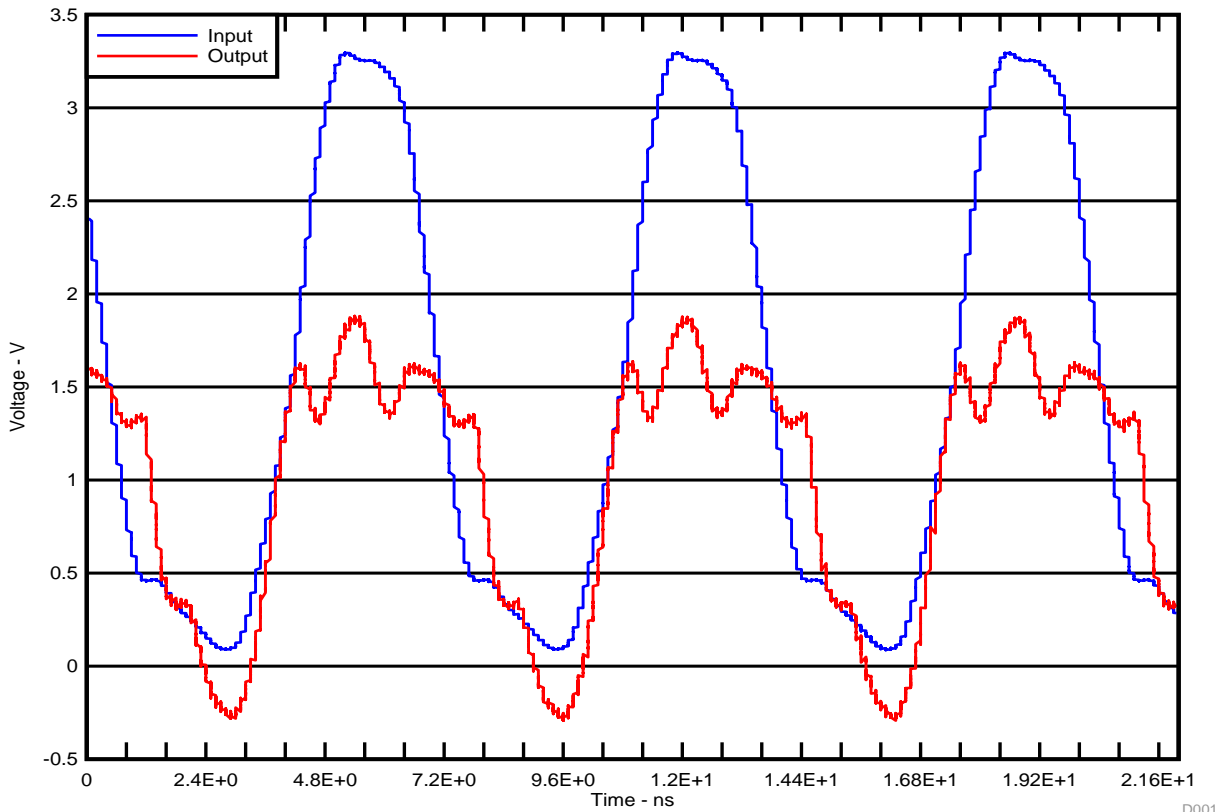

Figure 11. Translation Down (3.3 to 1.8 V) at 150 MHz

D001

10 Power Supply Recommendations

There are no power sequence requirements for the LSF family. For enable and reference voltage guidelines, please refer to the [Enable, Disable, and Reference Voltage Guidelines](#).

11 Layout

11.1 Layout Guidelines

Because the LSF family is a switch-type level translator, the signal integrity is highly related with a pull-up resistor and PCB capacitance condition.

- Short signal trace as possible to reduce capacitance and minimize stub from pull-up resistor.
- Place LSF close to high voltage side.
- Select the appropriate pull-up resistor that applies to translation levels and driving capability of transmitter.

11.2 Layout Example

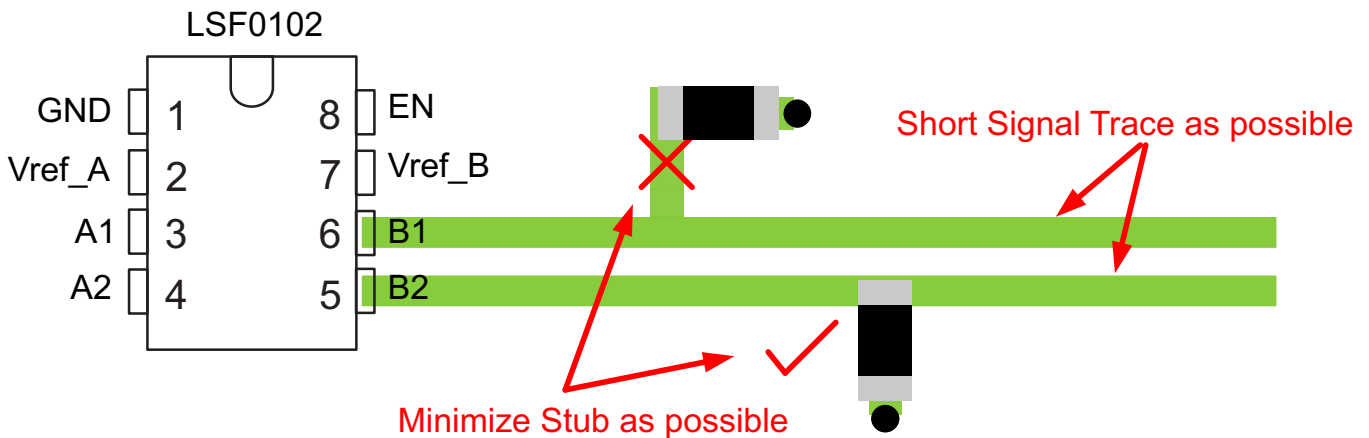

Figure 12. Short Trace Layout

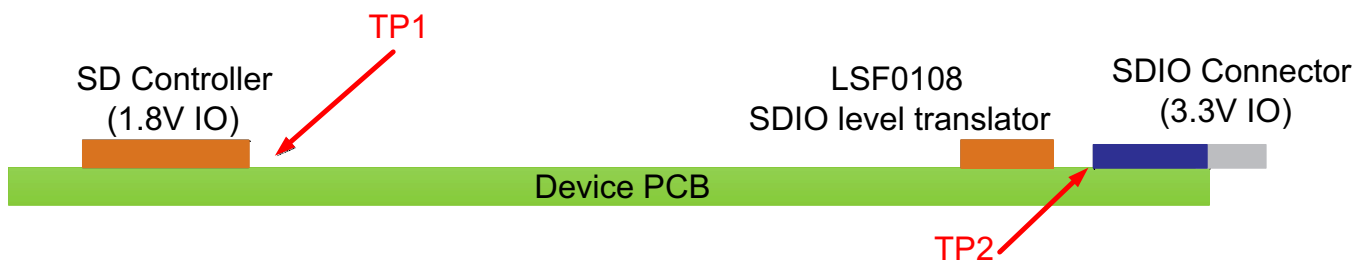
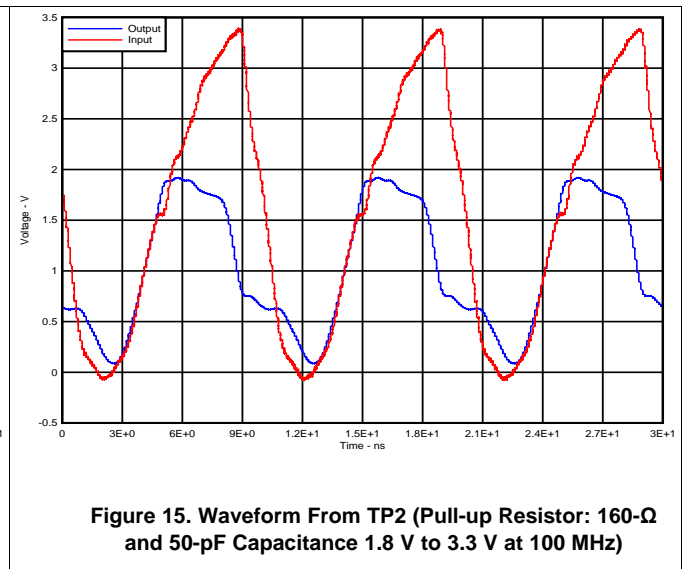
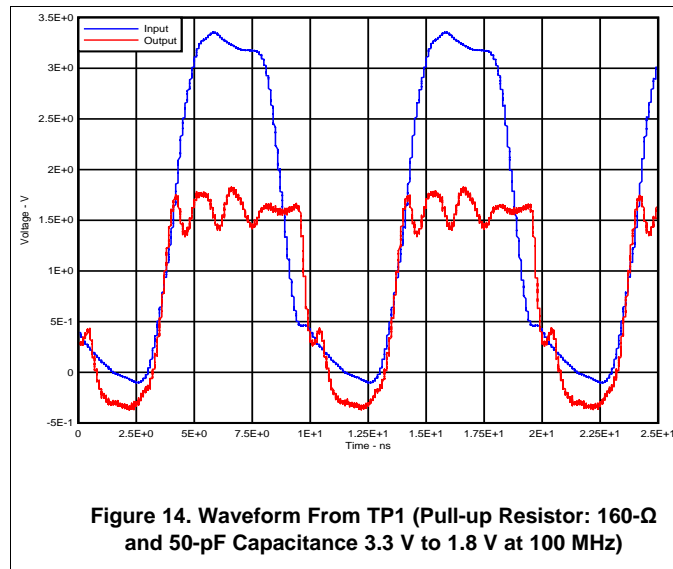

Figure 13. Device Placement

Layout Example (continued)

12 Device and Documentation Support

12.1 Related Links

The table below lists quick access links. Categories include technical documents, support and community resources, tools and software, and quick access to sample or buy.

Table 5. Related Links

PARTS	PRODUCT FOLDER	SAMPLE & BUY	TECHNICAL DOCUMENTS	TOOLS & SOFTWARE	SUPPORT & COMMUNITY
LSF0101	Click here	Click here	Click here	Click here	Click here
LSF0102	Click here	Click here	Click here	Click here	Click here
LSF0108	Click here	Click here	Click here	Click here	Click here

12.2 Community Resources

The following links connect to TI community resources. Linked contents are provided "AS IS" by the respective contributors. They do not constitute TI specifications and do not necessarily reflect TI's views; see TI's [Terms of Use](#).

TI E2E™ Online Community *TI's Engineer-to-Engineer (E2E) Community*. Created to foster collaboration among engineers. At e2e.ti.com, you can ask questions, share knowledge, explore ideas and help solve problems with fellow engineers.

Design Support *TI's Design Support* Quickly find helpful E2E forums along with design support tools and contact information for technical support.

12.3 Trademarks

E2E is a trademark of Texas Instruments.

All other trademarks are the property of their respective owners.

12.4 Electrostatic Discharge Caution



These devices have limited built-in ESD protection. The leads should be shorted together or the device placed in conductive foam during storage or handling to prevent electrostatic damage to the MOS gates.

12.5 Glossary

[SLYZ022](#) — *TI Glossary*.

This glossary lists and explains terms, acronyms, and definitions.

13 Mechanical, Packaging, and Orderable Information

The following pages include mechanical, packaging, and orderable information. This information is the most current data available for the designated devices. This data is subject to change without notice and revision of this document. For browser-based versions of this data sheet, refer to the left-hand navigation.

PACKAGING INFORMATION

Orderable Device	Status (1)	Package Type	Package Drawing	Pins	Package Qty	Eco Plan (2)	Lead/Ball Finish (6)	MSL Peak Temp (3)	Op Temp (°C)	Device Marking (4/5)	Samples
LSF0101DRYR	ACTIVE	SON	DRY	6	5000	Green (RoHS & no Sb/Br)	CU NIPDAU	Level-1-260C-UNLIM	-40 to 125	VD	Samples
LSF0102DCTR	ACTIVE	SM8	DCT	8	3000	Green (RoHS & no Sb/Br)	CU NIPDAU	Level-1-260C-UNLIM	-40 to 125	NG2 Y	Samples
LSF0102DCUR	ACTIVE	VSSOP	DCU	8	3000	Green (RoHS & no Sb/Br)	CU NIPDAU CU SN	Level-1-260C-UNLIM	-40 to 125	(G2 ~ NG2P ~ NG2S) NY	Samples
LSF0102DQER	ACTIVE	X2SON	DQE	8	5000	Green (RoHS & no Sb/Br)	CU NIPDAU	Level-1-260C-UNLIM	-40 to 125	RV	Samples
LSF0102YZTR	ACTIVE	DSBGA	YZT	8	3000	Green (RoHS & no Sb/Br)	SNAGCU	Level-1-260C-UNLIM	-40 to 125	RV	Samples
LSF0108PWR	ACTIVE	TSSOP	PW	20	2000	Green (RoHS & no Sb/Br)	CU SN	Level-1-260C-UNLIM	-40 to 125	LSF0108	Samples
LSF0108RKS	ACTIVE	VQFN	RKS	20	3000	Green (RoHS & no Sb/Br)	CU NIPDAU	Level-1-260C-UNLIM	-40 to 125	LSF0108	Samples

(1) The marketing status values are defined as follows:

ACTIVE: Product device recommended for new designs.

LIFEBUY: TI has announced that the device will be discontinued, and a lifetime-buy period is in effect.

NRND: Not recommended for new designs. Device is in production to support existing customers, but TI does not recommend using this part in a new design.

PREVIEW: Device has been announced but is not in production. Samples may or may not be available.

OBSELETE: TI has discontinued the production of the device.

(2) Eco Plan - The planned eco-friendly classification: Pb-Free (RoHS), Pb-Free (RoHS Exempt), or Green (RoHS & no Sb/Br) - please check <http://www.ti.com/productcontent> for the latest availability information and additional product content details.

TBD: The Pb-Free/Green conversion plan has not been defined.

Pb-Free (RoHS): TI's terms "Lead-Free" or "Pb-Free" mean semiconductor products that are compatible with the current RoHS requirements for all 6 substances, including the requirement that lead not exceed 0.1% by weight in homogeneous materials. Where designed to be soldered at high temperatures, TI Pb-Free products are suitable for use in specified lead-free processes.

Pb-Free (RoHS Exempt): This component has a RoHS exemption for either 1) lead-based flip-chip solder bumps used between the die and package, or 2) lead-based die adhesive used between the die and leadframe. The component is otherwise considered Pb-Free (RoHS compatible) as defined above.

Green (RoHS & no Sb/Br): TI defines "Green" to mean Pb-Free (RoHS compatible), and free of Bromine (Br) and Antimony (Sb) based flame retardants (Br or Sb do not exceed 0.1% by weight in homogeneous material)

(3) MSL, Peak Temp. - The Moisture Sensitivity Level rating according to the JEDEC industry standard classifications, and peak solder temperature.

(4) There may be additional marking, which relates to the logo, the lot trace code information, or the environmental category on the device.

⁽⁵⁾ Multiple Device Markings will be inside parentheses. Only one Device Marking contained in parentheses and separated by a "-" will appear on a device. If a line is indented then it is a continuation of the previous line and the two combined represent the entire Device Marking for that device.

⁽⁶⁾ Lead/Ball Finish - Orderable Devices may have multiple material finish options. Finish options are separated by a vertical ruled line. Lead/Ball Finish values may wrap to two lines if the finish value exceeds the maximum column width.

Important Information and Disclaimer:The information provided on this page represents TI's knowledge and belief as of the date that it is provided. TI bases its knowledge and belief on information provided by third parties, and makes no representation or warranty as to the accuracy of such information. Efforts are underway to better integrate information from third parties. TI has taken and continues to take reasonable steps to provide representative and accurate information but may not have conducted destructive testing or chemical analysis on incoming materials and chemicals. TI and TI suppliers consider certain information to be proprietary, and thus CAS numbers and other limited information may not be available for release.

In no event shall TI's liability arising out of such information exceed the total purchase price of the TI part(s) at issue in this document sold by TI to Customer on an annual basis.

TAPE AND REEL INFORMATION

QUADRANT ASSIGNMENTS FOR PIN 1 ORIENTATION IN TAPE

*All dimensions are nominal

Device	Package Type	Package Drawing	Pins	SPQ	Reel Diameter (mm)	Reel Width W1 (mm)	A0 (mm)	B0 (mm)	K0 (mm)	P1 (mm)	W (mm)	Pin1 Quadrant
LSF0101DRYR	SON	DRY	6	5000	180.0	9.5	1.15	1.6	0.75	4.0	8.0	Q1
LSF0102DCTR	SM8	DCT	8	3000	180.0	13.0	3.35	4.5	1.55	4.0	12.0	Q3
LSF0102DCUR	VSSOP	DCU	8	3000	180.0	8.4	2.25	3.35	1.05	4.0	8.0	Q3
LSF0102DCUR	VSSOP	DCU	8	3000	178.0	9.5	2.25	3.35	1.05	4.0	8.0	Q3
LSF0102DCUR	VSSOP	DCU	8	3000	180.0	9.0	2.05	3.3	1.0	4.0	8.0	Q3
LSF0102DQER	X2SON	DQE	8	5000	180.0	9.5	1.15	1.6	0.5	4.0	8.0	Q1
LSF0102YZTR	DSBGA	YZT	8	3000	180.0	8.4	1.02	2.02	0.75	4.0	8.0	Q1
LSF0108PWR	TSSOP	PW	20	2000	330.0	16.4	6.95	7.1	1.6	8.0	16.0	Q1
LSF0108RKSR	VQFN	RKS	20	3000	177.8	12.4	2.73	4.85	1.03	4.0	12.0	Q1

TAPE AND REEL BOX DIMENSIONS

*All dimensions are nominal

Device	Package Type	Package Drawing	Pins	SPQ	Length (mm)	Width (mm)	Height (mm)
LSF0101DRYR	SON	DRY	6	5000	184.0	184.0	19.0
LSF0102DCTR	SM8	DCT	8	3000	182.0	182.0	20.0
LSF0102DCUR	VSSOP	DCU	8	3000	202.0	201.0	28.0
LSF0102DCUR	VSSOP	DCU	8	3000	202.0	201.0	28.0
LSF0102DCUR	VSSOP	DCU	8	3000	182.0	182.0	20.0
LSF0102DQER	X2SON	DQE	8	5000	184.0	184.0	19.0
LSF0102YZTR	DSBGA	YZT	8	3000	182.0	182.0	20.0
LSF0108PWR	TSSOP	PW	20	2000	364.0	364.0	27.0
LSF0108RKSR	VQFN	RKS	20	3000	202.0	201.0	28.0

DCT (R-PDSO-G8)

PLASTIC SMALL-OUTLINE PACKAGE

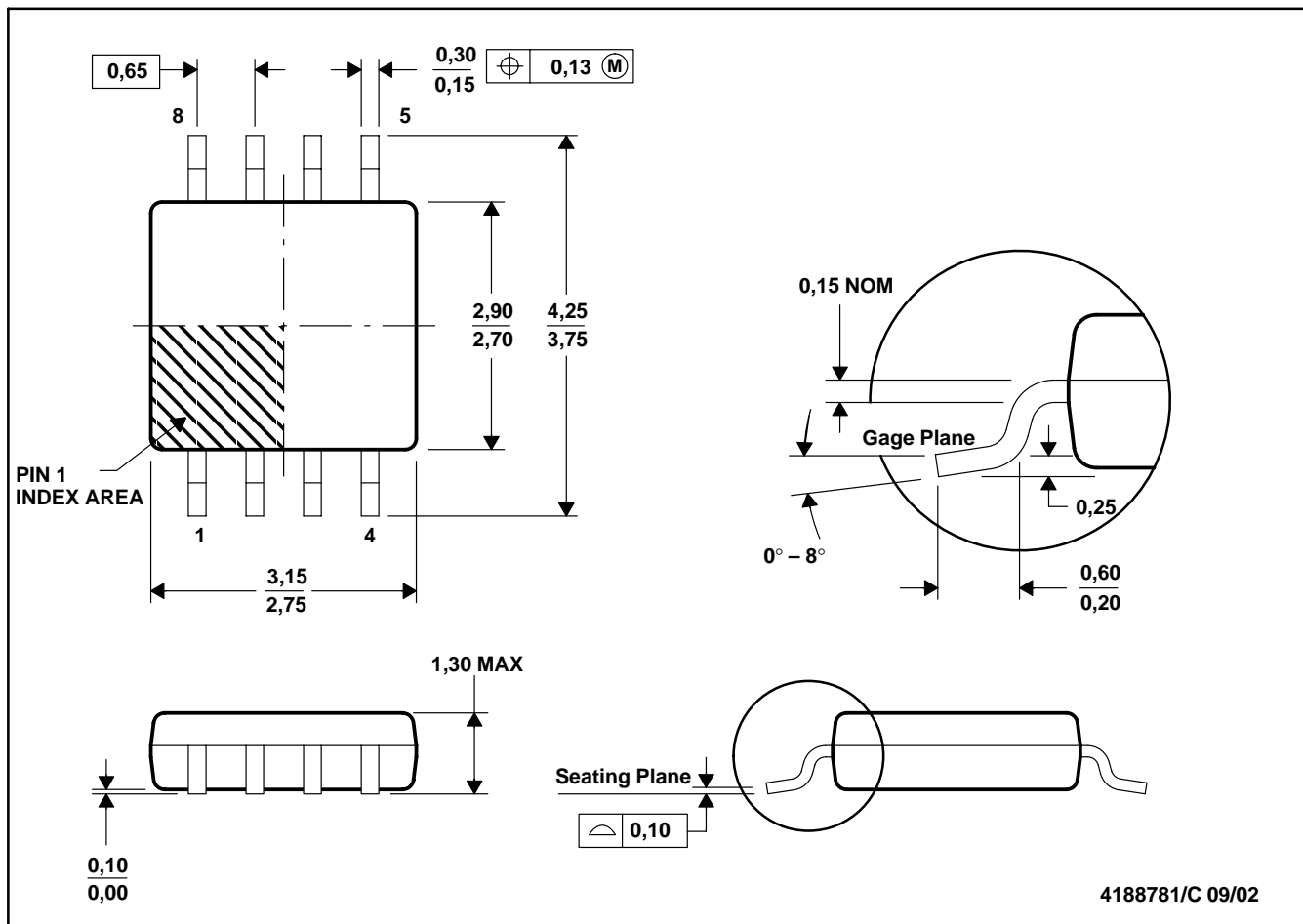

- NOTES: A. All linear dimensions are in millimeters.
 B. This drawing is subject to change without notice.
 C. Body dimensions do not include mold flash or protrusion
 D. Falls within JEDEC MO-187 variation DA.

DCT (R-PDSO-G8)

PLASTIC SMALL OUTLINE



- NOTES:
- A. All linear dimensions are in millimeters.
 - B. This drawing is subject to change without notice.
 - C. Publication IPC-7351 is recommended for alternate designs.
 - D. Laser cutting apertures with trapezoidal walls and also rounding corners will offer better paste release. Customers should contact their board assembly site for stencil design recommendations. Refer to IPC-7525.
 - E. Customers should contact their board fabrication site for solder mask tolerances between and around signal pads.

DCU (R-PDSO-G8)

PLASTIC SMALL-OUTLINE PACKAGE (DIE DOWN)

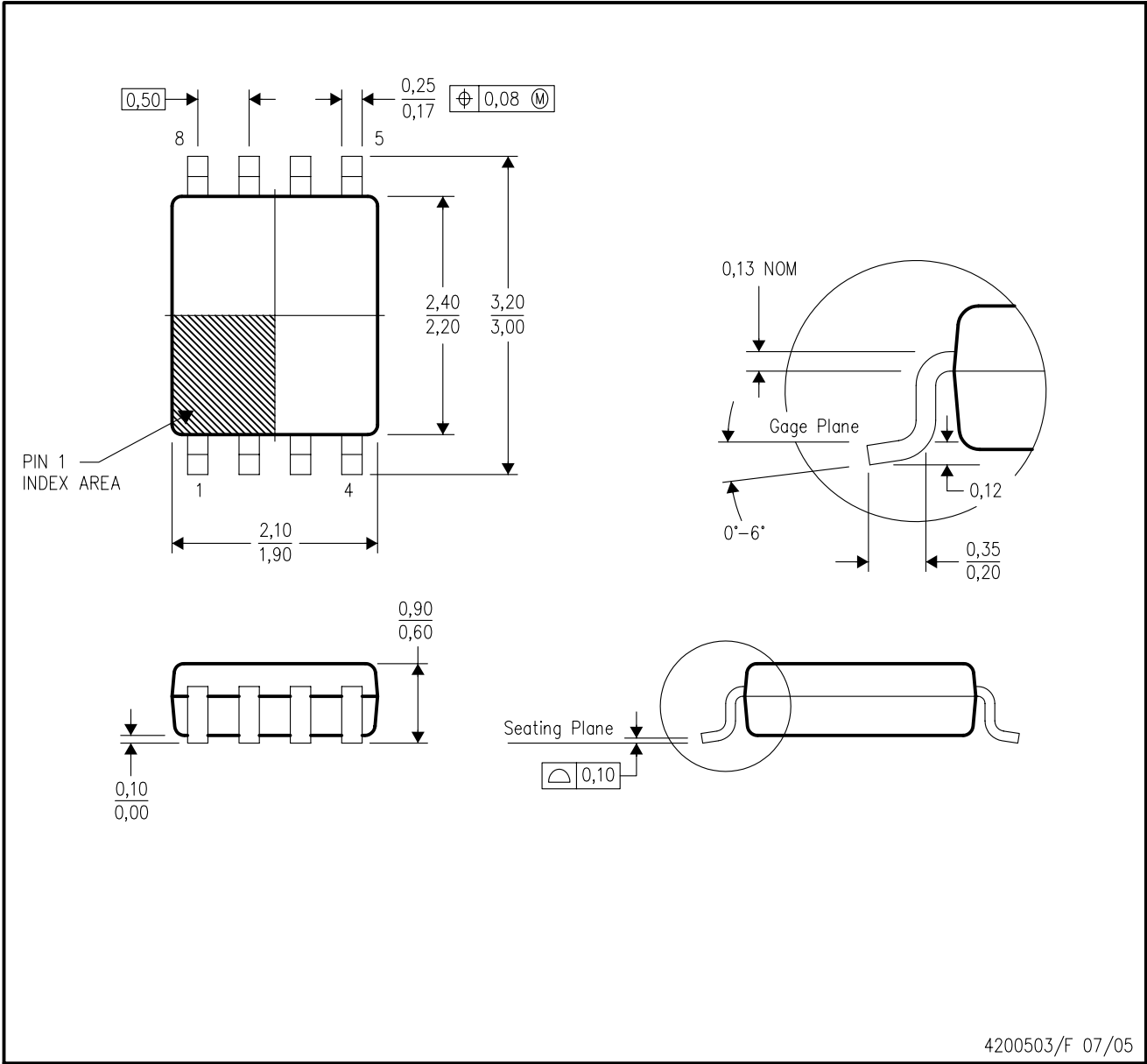

- NOTES:
- A. All linear dimensions are in millimeters.
 - B. This drawing is subject to change without notice.
 - C. Body dimensions do not include mold flash or protrusion. Mold flash and protrusion shall not exceed 0.15 per side.
 - D. Falls within JEDEC MO-187 variation CA.

DCU (S-PDSO-G8)

PLASTIC SMALL OUTLINE PACKAGE (DIE DOWN)

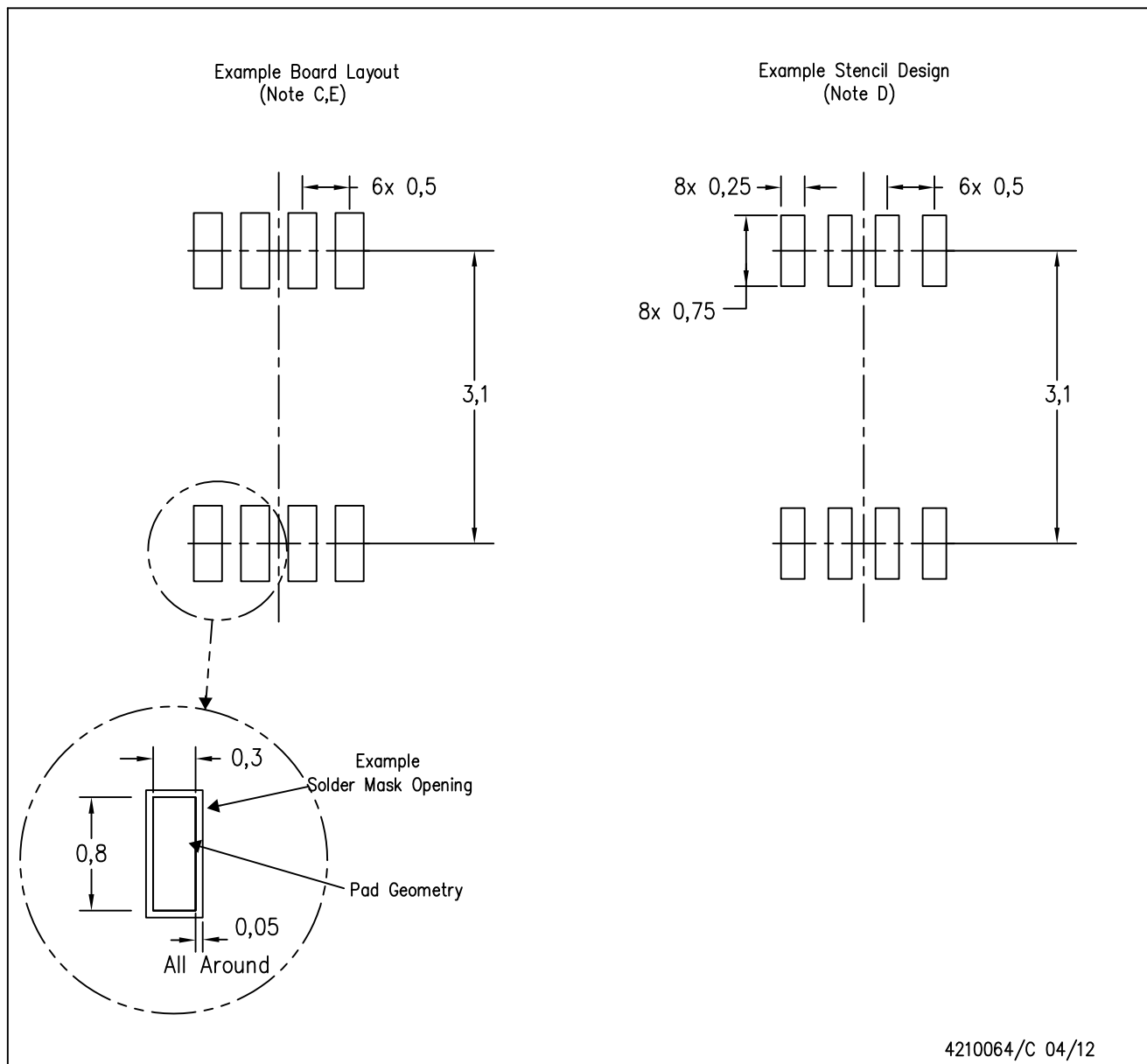

4210064/C 04/12

- NOTES:
- A. All linear dimensions are in millimeters.
 - B. This drawing is subject to change without notice.
 - C. Publication IPC-7351 is recommended for alternate designs.
 - D. Laser cutting apertures with trapezoidal walls and also rounding corners will offer better paste release. Customers should contact their board assembly site for stencil design recommendations. Refer to IPC-7525 for other stencil recommendations.
 - E. Customers should contact their board fabrication site for solder mask tolerances between and around signal pads.

DRY (R-PUSON-N6)

PLASTIC SMALL OUTLINE NO-LEAD

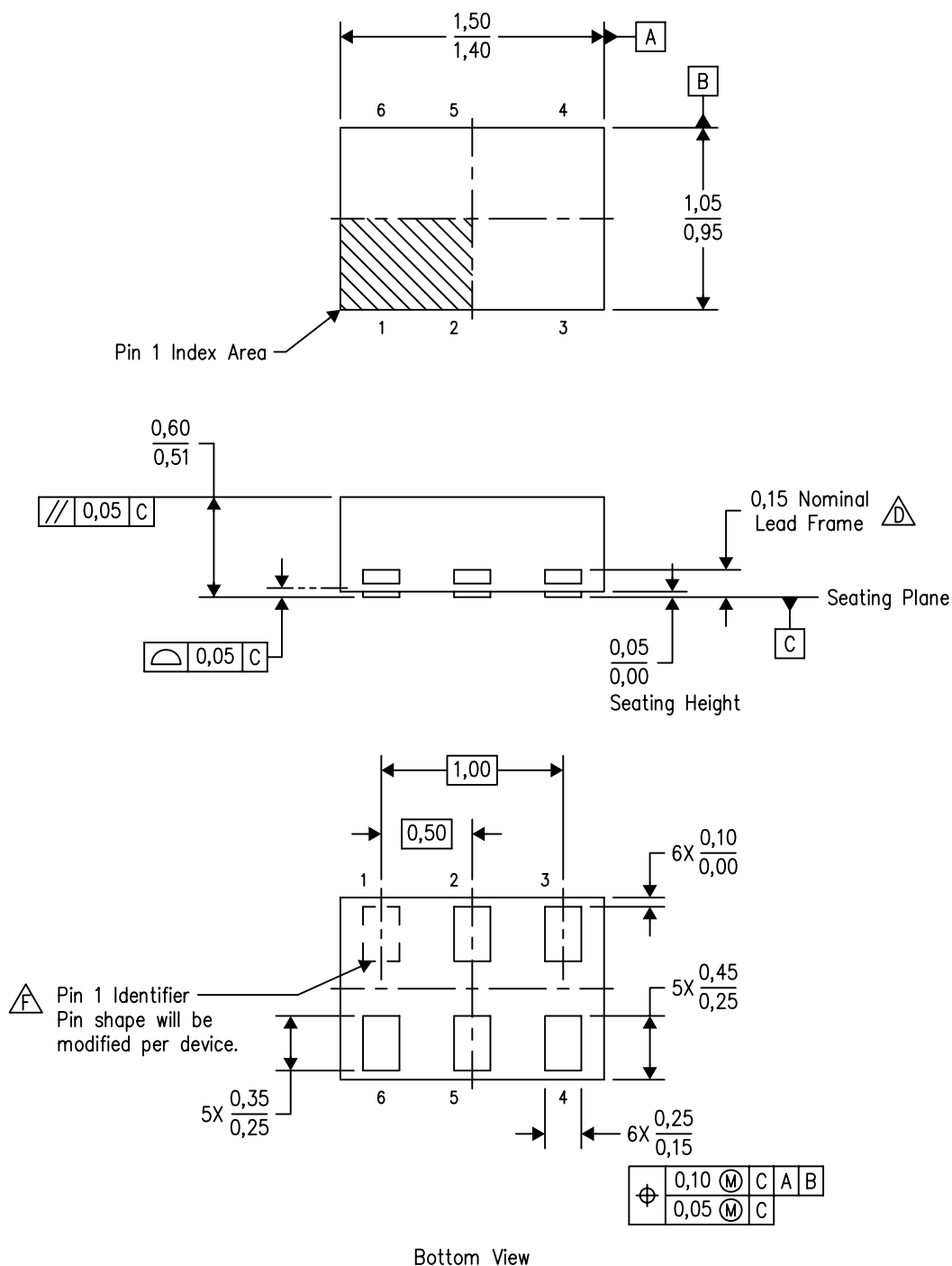

4207181/F 12/11

- NOTES:
- A. All linear dimensions are in millimeters. Dimensioning and tolerancing per ASME Y14.5M-1994.
 - B. This drawing is subject to change without notice.
 - C. SON (Small Outline No-Lead) package configuration.
 - $\triangle D$ The exposed lead frame feature on side of package may or may not be present due to alternative lead frame designs.
 - E. This package complies to JEDEC MO-287 variation UFAD.
 - $\triangle F$ See the additional figure in the Product Data Sheet for details regarding the pin 1 identifier shape.

DRY (R-PUSON-N6)

PLASTIC SMALL OUTLINE NO-LEAD

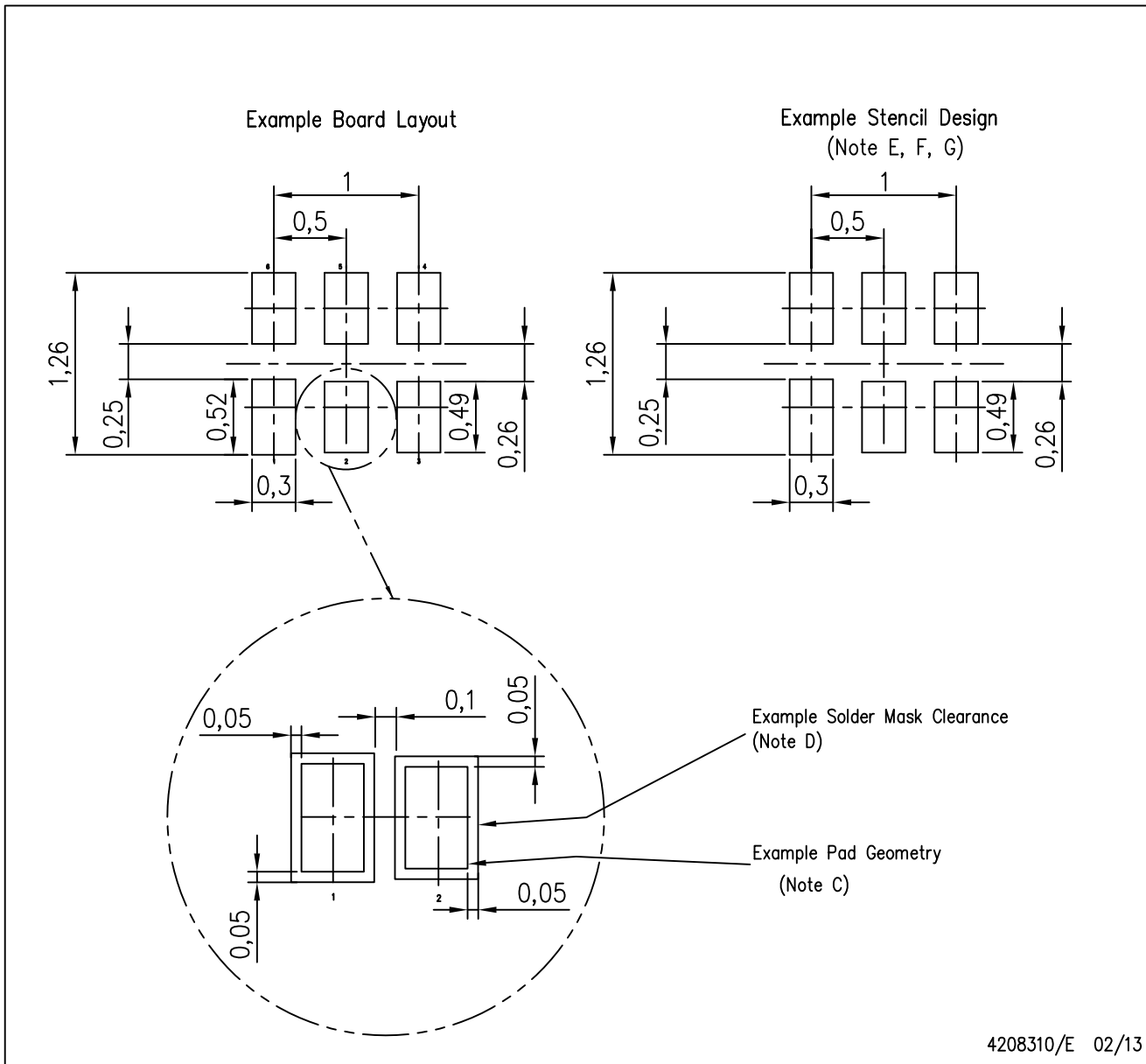

- NOTES:
- All linear dimensions are in millimeters.
 - This drawing is subject to change without notice.
 - Publication IPC-7351 is recommended for alternate designs.
 - Customers should contact their board fabrication site for minimum solder mask web tolerances between signal pads.
 - Maximum stencil thickness 0,127 mm (5 mils). All linear dimensions are in millimeters.
 - Laser cutting apertures with trapezoidal walls and also rounding corners will offer better paste release. Customers should contact their board assembly site for stencil design recommendations. Refer to IPC 7525 for stencil design considerations.
 - Side aperture dimensions over-print land for acceptable area ratio > 0.66 . Customer may reduce side aperture dimensions if stencil manufacturing process allows for sufficient release at smaller opening.

PW (R-PDSO-G20)

PLASTIC SMALL OUTLINE



- NOTES:
- A. All linear dimensions are in millimeters. Dimensioning and tolerancing per ASME Y14.5M-1994.
 - B. This drawing is subject to change without notice.
 - △ C Body length does not include mold flash, protrusions, or gate burrs. Mold flash, protrusions, or gate burrs shall not exceed 0,15 each side.
 - △ D Body width does not include interlead flash. Interlead flash shall not exceed 0,25 each side.
 - E. Falls within JEDEC MO-153

PW (R-PDSO-G20)

PLASTIC SMALL OUTLINE



- NOTES:
- A. All linear dimensions are in millimeters.
 - B. This drawing is subject to change without notice.
 - C. Publication IPC-7351 is recommended for alternate design.
 - D. Laser cutting apertures with trapezoidal walls and also rounding corners will offer better paste release. Customers should contact their board assembly site for stencil design recommendations. Refer to IPC-7525 for other stencil recommendations.
 - E. Customers should contact their board fabrication site for solder mask tolerances between and around signal pads.

RKS (R-PVQFN-N20)

PLASTIC QUAD FLATPACK NO-LEAD

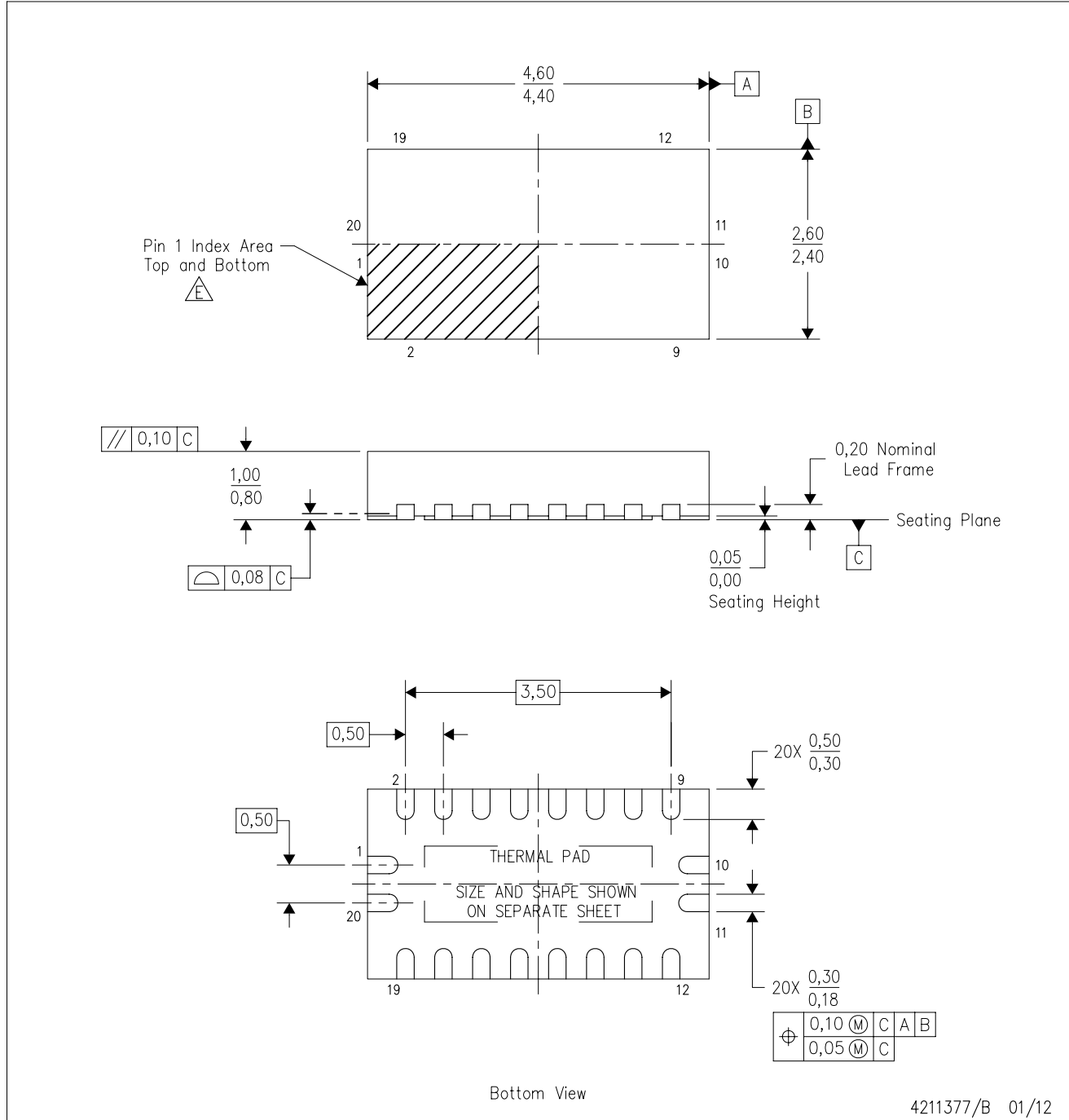

- NOTES:
- A. All linear dimensions are in millimeters. Dimensioning and tolerancing per ASME Y14.5M-1994.
 - B. This drawing is subject to change without notice.
 - C. QFN (Quad Flatpack No-Lead) package configuration.
 - D. The package thermal pad must be soldered to the board for thermal and mechanical performance.
 - E. See the additional figure in the Product Data Sheet for details regarding the exposed thermal pad features and dimensions.
- △ Pin 1 identifiers are located on both top and bottom of the package and within the zone indicated. The Pin 1 identifiers are either a molded, marked, or metal feature.

THERMAL PAD MECHANICAL DATA

RKS (R-PVQFN-N20)

PLASTIC QUAD FLATPACK NO-LEAD

THERMAL INFORMATION

This package incorporates an exposed thermal pad that is designed to be attached directly to an external heatsink. The thermal pad must be soldered directly to the printed circuit board (PCB). After soldering, the PCB can be used as a heatsink. In addition, through the use of thermal vias, the thermal pad can be attached directly to the appropriate copper plane shown in the electrical schematic for the device, or alternatively, can be attached to a special heatsink structure designed into the PCB. This design optimizes the heat transfer from the integrated circuit (IC).

For information on the Quad Flatpack No-Lead (QFN) package and its advantages, refer to Application Report, QFN/SON PCB Attachment, Texas Instruments Literature No. SLUA271. This document is available at www.ti.com.

The exposed thermal pad dimensions for this package are shown in the following illustration.

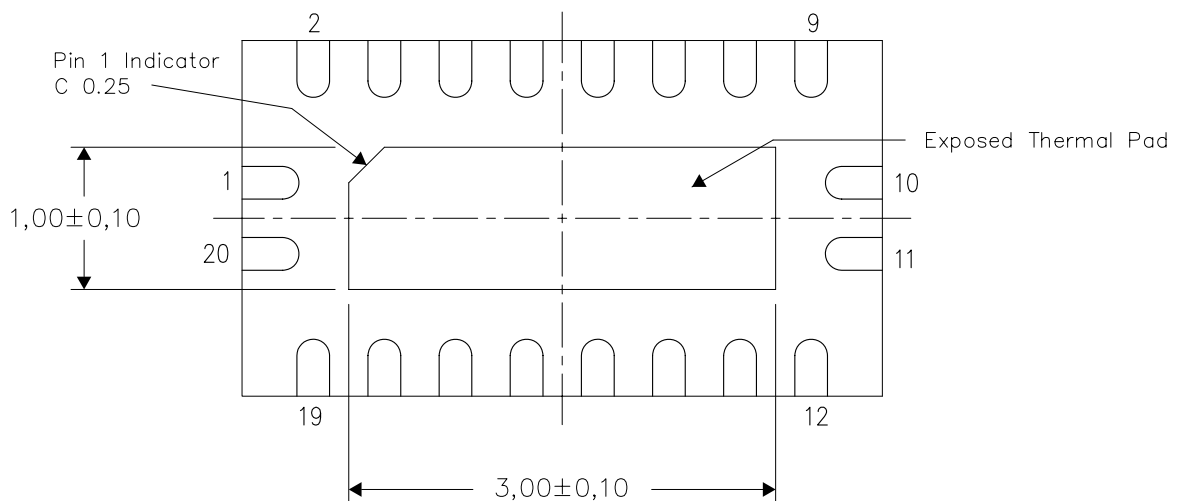

Bottom View

Exposed Thermal Pad Dimensions

4211394/B 01/12

NOTE: All linear dimensions are in millimeters

MECHANICAL DATA

DQE (R-PX2SON-N8)

PLASTIC SMALL OUTLINE NO-LEAD

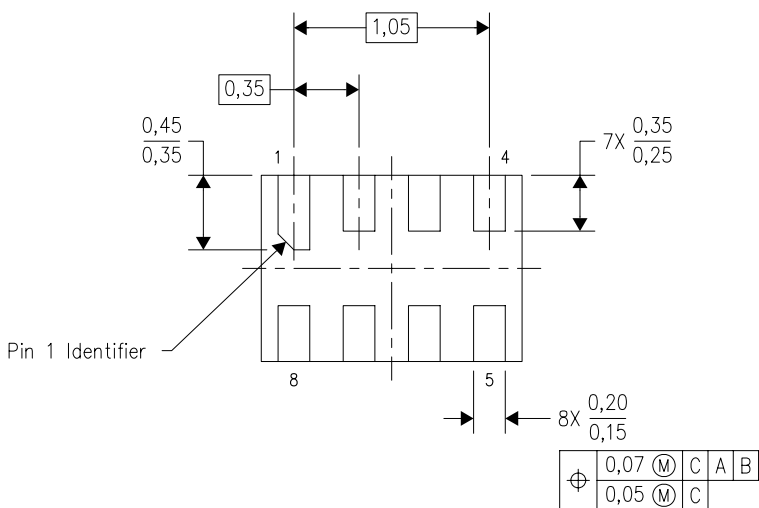
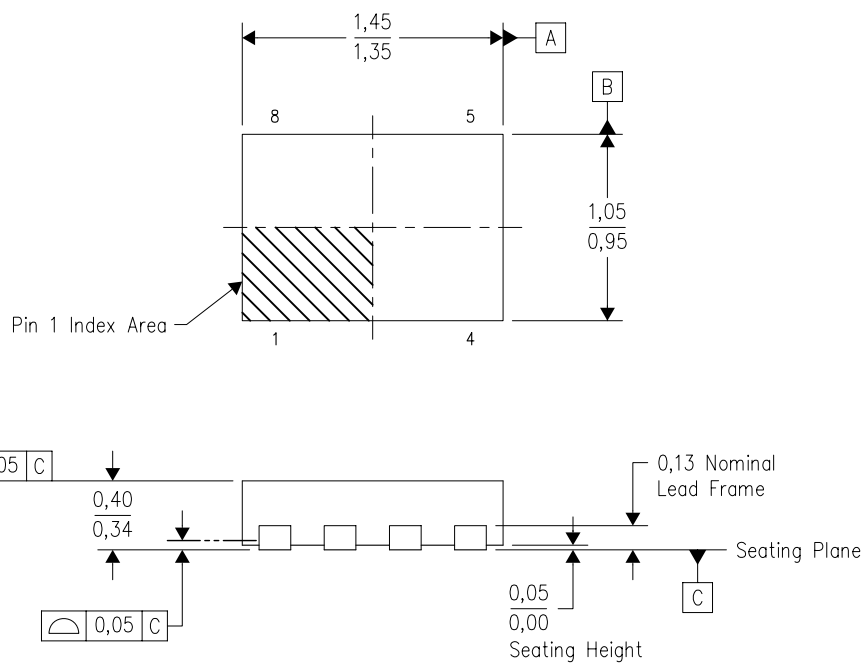

Bottom View

4209779/B 10/2008

- NOTES: A. All linear dimensions are in millimeters. Dimensioning and tolerancing per ASME Y14.5M-1994.
 B. This drawing is subject to change without notice.
 C. SON (Small Outline No-Lead) package configuration.
 D. This package complies to JEDEC MO-287 variation X2EAF.

DQE (R-PX2SON-N8)

PLASTIC SMALL OUTLINE NO-LEAD

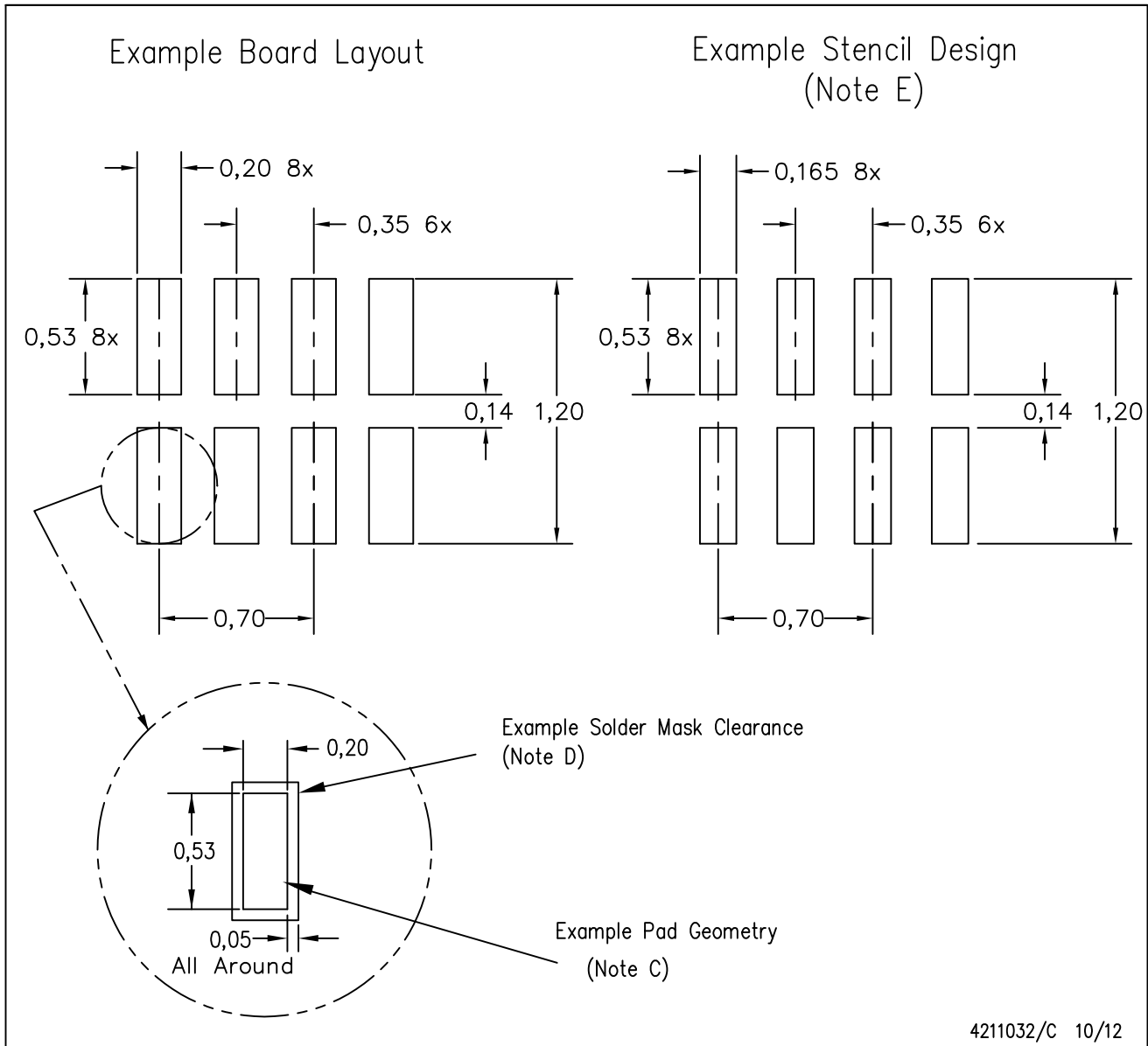

- NOTES:
- A. All linear dimensions are in millimeters.
 - B. This drawing is subject to change without notice.
 - C. Publication IPC-7351 is recommended for alternate designs.
 - D. Customers should contact their board fabrication site for minimum solder mask web tolerances between signal pads.
If 2 mil solder mask is outside PCB vendor capability, it is advised to omit solder mask.
 - E. Maximum stencil thickness 0,1016 mm (4 mils). All linear dimensions are in millimeters.
 - F. Laser cutting apertures with trapezoidal walls and also rounding corners will offer better paste release. Customers should contact their board assembly site for stencil design recommendations. Refer to IPC 7525 for stencil design considerations.
 - G. Over-printing land for acceptable area ratio is not viable due to land width and bridging potential. Customer may further reduce side aperture dimensions if stencil manufacturing process allows for sufficient release at smaller opening.
 - H. Suggest stencils cut with lasers such as Fiber Laser that produce the greatest positional accuracy.
 - I. Component placement force should be minimized to prevent excessive paste block deformation.

MECHANICAL DATA

YZT (R-XBGA-N8)

DIE-SIZE BALL GRID ARRAY

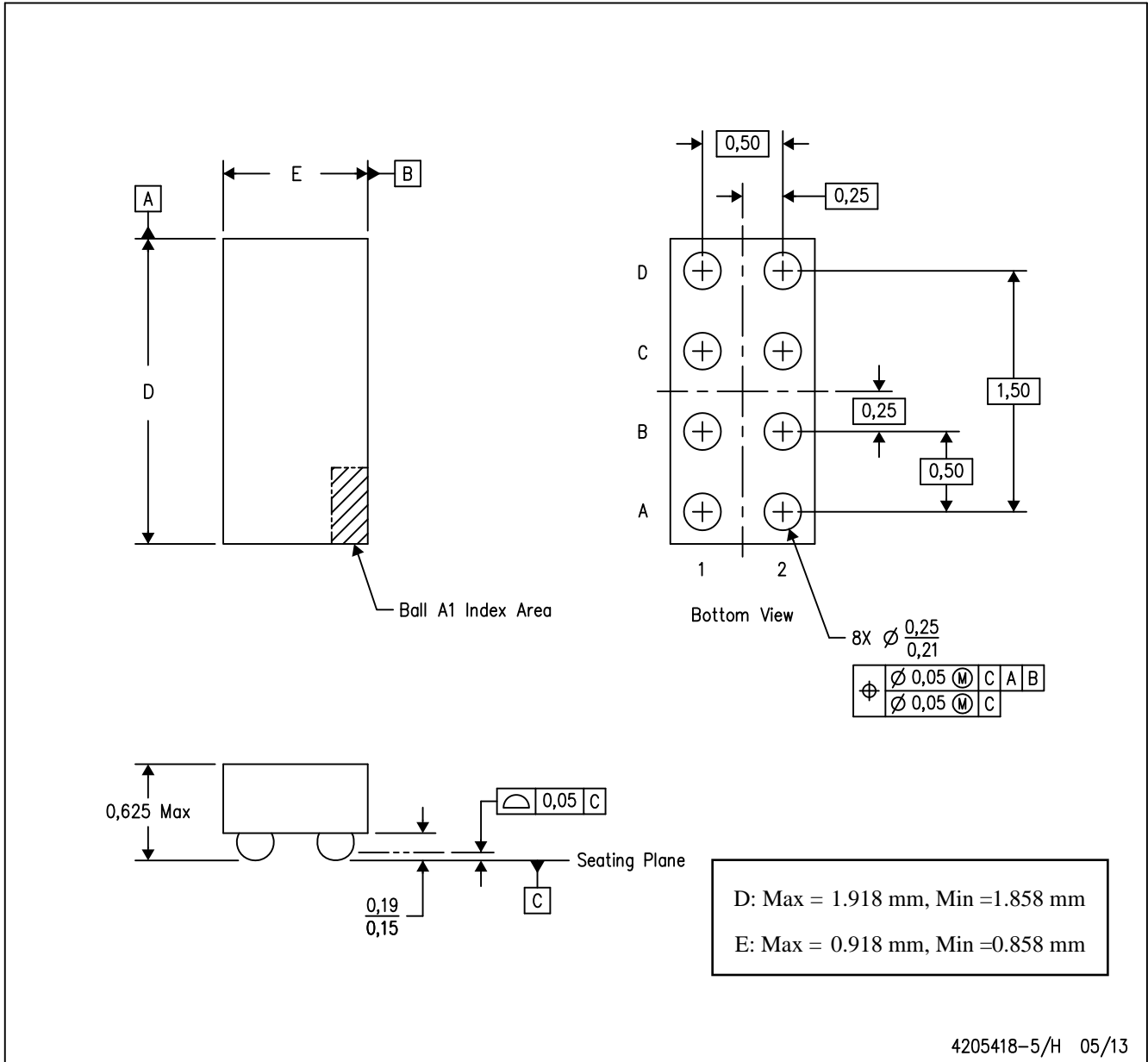

- NOTES:
- A. All linear dimensions are in millimeters. Dimensioning and tolerancing per ASME Y14.5M-1994.
 - B. This drawing is subject to change without notice.
 - C. NanoFree™ package configuration.

NanoFree is a trademark of Texas Instruments.

IMPORTANT NOTICE

Texas Instruments Incorporated and its subsidiaries (TI) reserve the right to make corrections, enhancements, improvements and other changes to its semiconductor products and services per JESD46, latest issue, and to discontinue any product or service per JESD48, latest issue. Buyers should obtain the latest relevant information before placing orders and should verify that such information is current and complete. All semiconductor products (also referred to herein as "components") are sold subject to TI's terms and conditions of sale supplied at the time of order acknowledgment.

TI warrants performance of its components to the specifications applicable at the time of sale, in accordance with the warranty in TI's terms and conditions of sale of semiconductor products. Testing and other quality control techniques are used to the extent TI deems necessary to support this warranty. Except where mandated by applicable law, testing of all parameters of each component is not necessarily performed.

TI assumes no liability for applications assistance or the design of Buyers' products. Buyers are responsible for their products and applications using TI components. To minimize the risks associated with Buyers' products and applications, Buyers should provide adequate design and operating safeguards.

TI does not warrant or represent that any license, either express or implied, is granted under any patent right, copyright, mask work right, or other intellectual property right relating to any combination, machine, or process in which TI components or services are used. Information published by TI regarding third-party products or services does not constitute a license to use such products or services or a warranty or endorsement thereof. Use of such information may require a license from a third party under the patents or other intellectual property of the third party, or a license from TI under the patents or other intellectual property of TI.

Reproduction of significant portions of TI information in TI data books or data sheets is permissible only if reproduction is without alteration and is accompanied by all associated warranties, conditions, limitations, and notices. TI is not responsible or liable for such altered documentation. Information of third parties may be subject to additional restrictions.

Resale of TI components or services with statements different from or beyond the parameters stated by TI for that component or service voids all express and any implied warranties for the associated TI component or service and is an unfair and deceptive business practice. TI is not responsible or liable for any such statements.

Buyer acknowledges and agrees that it is solely responsible for compliance with all legal, regulatory and safety-related requirements concerning its products, and any use of TI components in its applications, notwithstanding any applications-related information or support that may be provided by TI. Buyer represents and agrees that it has all the necessary expertise to create and implement safeguards which anticipate dangerous consequences of failures, monitor failures and their consequences, lessen the likelihood of failures that might cause harm and take appropriate remedial actions. Buyer will fully indemnify TI and its representatives against any damages arising out of the use of any TI components in safety-critical applications.

In some cases, TI components may be promoted specifically to facilitate safety-related applications. With such components, TI's goal is to help enable customers to design and create their own end-product solutions that meet applicable functional safety standards and requirements. Nonetheless, such components are subject to these terms.

No TI components are authorized for use in FDA Class III (or similar life-critical medical equipment) unless authorized officers of the parties have executed a special agreement specifically governing such use.

Only those TI components which TI has specifically designated as military grade or "enhanced plastic" are designed and intended for use in military/aerospace applications or environments. Buyer acknowledges and agrees that any military or aerospace use of TI components which have **not** been so designated is solely at the Buyer's risk, and that Buyer is solely responsible for compliance with all legal and regulatory requirements in connection with such use.

TI has specifically designated certain components as meeting ISO/TS16949 requirements, mainly for automotive use. In any case of use of non-designated products, TI will not be responsible for any failure to meet ISO/TS16949.

Products

Audio	www.ti.com/audio
Amplifiers	amplifier.ti.com
Data Converters	dataconverter.ti.com
DLP® Products	www.dlp.com
DSP	dsp.ti.com
Clocks and Timers	www.ti.com/clocks
Interface	interface.ti.com
Logic	logic.ti.com
Power Mgmt	power.ti.com
Microcontrollers	microcontroller.ti.com
RFID	www.ti-rfid.com
OMAP Applications Processors	www.ti.com/omap
Wireless Connectivity	www.ti.com/wirelessconnectivity

Applications

Automotive and Transportation	www.ti.com/automotive
Communications and Telecom	www.ti.com/communications
Computers and Peripherals	www.ti.com/computers
Consumer Electronics	www.ti.com/consumer-apps
Energy and Lighting	www.ti.com/energy
Industrial	www.ti.com/industrial
Medical	www.ti.com/medical
Security	www.ti.com/security
Space, Avionics and Defense	www.ti.com/space-avionics-defense
Video and Imaging	www.ti.com/video

TI E2E Community

e2e.ti.com