

## Remote I/O R8 Series

### DC VOLTAGE/CURRENT INPUT MODULE

(built-in excitation, 4 points, non-isolated)

#### Functions & Features

- DC current input and DC voltage input compact size remote I/O module
- Switching between current input and voltage input with PC configurator (model: R8CFG)
- Accepts direct input from power output as sensor power and outputs from terminals
- Each channel is attachable/detachable independently with separable tension clamp terminal.

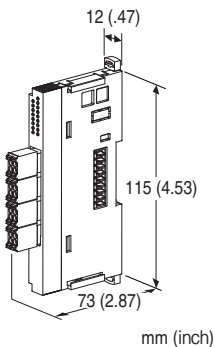

## MODEL: R8-FST4N[1]

### ORDERING INFORMATION

- Code number: R8-FST4N[1]  
Specify a code from below for [1].  
(e.g. R8-FST4N/Q)
- Specify the specification for option code /Q  
(e.g. /C01)

### [1] OPTIONS

blank: none

/Q: With options (specify the specification)

### SPECIFICATIONS OF OPTION: Q

**COATING (For the detail, refer to M-System's web site.)**

/C01: Silicone coating

/C02: Polyurethane coating

### RELATED PRODUCTS

- PC configurator software (model: R8CFG)  
The configurator software is downloadable at M-System's web site.  
A dedicated cable is required to connect the module to the

PC. Please refer to the users manual for the PC configurator for applicable cable types.

### GENERAL SPECIFICATIONS

#### Connection

- **Input:** Tension clamp
- **Excitation supply, internal bus:**  
Connected to internal bus connector
- **Internal power:** Via bus connector

**Isolation:** Input or exc. supply to internal bus or internal power

**Input type:** Configuration mode that selectable between current input and voltage input and available to configure scaling individually for each 4 points with configurator software (model: R8CFG) and fixed input mode that selectable between 0 - 10 V DC and 4 - 20 mA DC individually for each 4 points are available.

**Module address:** With rotary switch

**Terminating resistor:** Built-in (DIP Switch, default: disable)

**Status indicator:** Bi-color (red/green) LED; Refer to the instruction manual.

**Input status indicators:** Red LED; Refer to the instruction manual.

### INPUT SPECIFICATIONS

#### ■ DC Voltage:

- **Configuration mode**

**Input range:** -10 - +10 V DC

**Input setting value:** Available to set in the input range

**Operational range:** -5 - +105 % (% of input setting value)

**Input resistance:**  $\geq 1 \text{ M}\Omega$

- **Fixed input mode**

**Input range:** 0 - 10 V DC

**Input setting value:** Available to set in the input range

**Operational range:** -5 - +105 % (% of input setting value)

**Input resistance:**  $\geq 1 \text{ M}\Omega$

#### ■ DC Current:

- **Configuration mode**

**Input range:** -20 - +20 mA DC

**Input setting value:** Available to set in the input range

**Operational range:** -5 - +105 % (% of input setting value)

**Input resistance:** 50  $\Omega$  (1/4 W)

- **Fixed input mode**

**Input range:** 4 - 20 mA DC

**Input setting value:** Available to set in the input range

**Operational range:** -5 - +105 % (% of input setting value)

**Input resistance:** 50  $\Omega$  (1/4 W)

Factory default (Input type and input setting value):

Voltage input, input range -10 - +10 V DC for all 4 points.

**INSTALLATION**

**Max. current consumption:** 100 mA  
**Operating temperature:** -10 to +55°C (14 to 131°F)  
**Operating humidity:** 30 to 90 %RH (non-condensing)  
**Atmosphere:** No corrosive gas or heavy dust  
**Mounting:** DIN rail  
**Weight:** 80 g (0.18 lb)

**PERFORMANCE**

**Conversion accuracy (in percentage of input range)**  
**Voltage input:** ±0.05 %  
**Current input:** ±0.1 %  
Conversion accuracy is inversely proportional to input span.  
**Conversion rate:** 8 msec.  
**Input circuit time constant:** Approx. 1 msec.  
**Data range:** 0 - 10000 of the input range  
(Scaling of converted data is configurable with the configurator software)  
**Data allocation:** 2  
**Module addresses in use:** 2  
**Power output (input connector):** Rated current 0.5 A DC per channel (rated current 3 A for internal fuse (slow blow fuse  $i^2t$  (A<sup>2</sup>sec.) max. 5.04); Total: 1 A DC  
**Temp. coefficient:** ±0.015 %/°C (±0.008 %/°F)  
**Insulation resistance:** ≥ 100 MΩ with 500 V DC  
**Dielectric strength:** 1500 V AC @ 1 minute  
(input or exc. supply to internal bus or internal power to ground)

**CALCULATION EXAMPLES OF CONVERSION ACCURACY****■ Voltage input:**

For input setting value 1 - 5 V DC  
Conversion accuracy = Input range span (20 V) ÷ input setting value span (4 V) × 0.05 (%) = 0.25 (%)

**■ Current input:**

For input setting value 4 - 20 mA DC  
Conversion accuracy = Input range span (40 mA) ÷ input setting value span (16 mA) × 0.1 (%) = 0.25 (%)  
(Span is common for configuration mode and fixed input mode)

**STANDARDS & APPROVALS****EU conformity:**

EMC Directive  
EMI EN 61000-6-4  
EMS EN 61000-6-2  
RoHS Directive  
EN 50581

## EXTERNAL VIEW

■ LEFT VIEW

■ FRONT VIEW

■ RIGHT VIEW

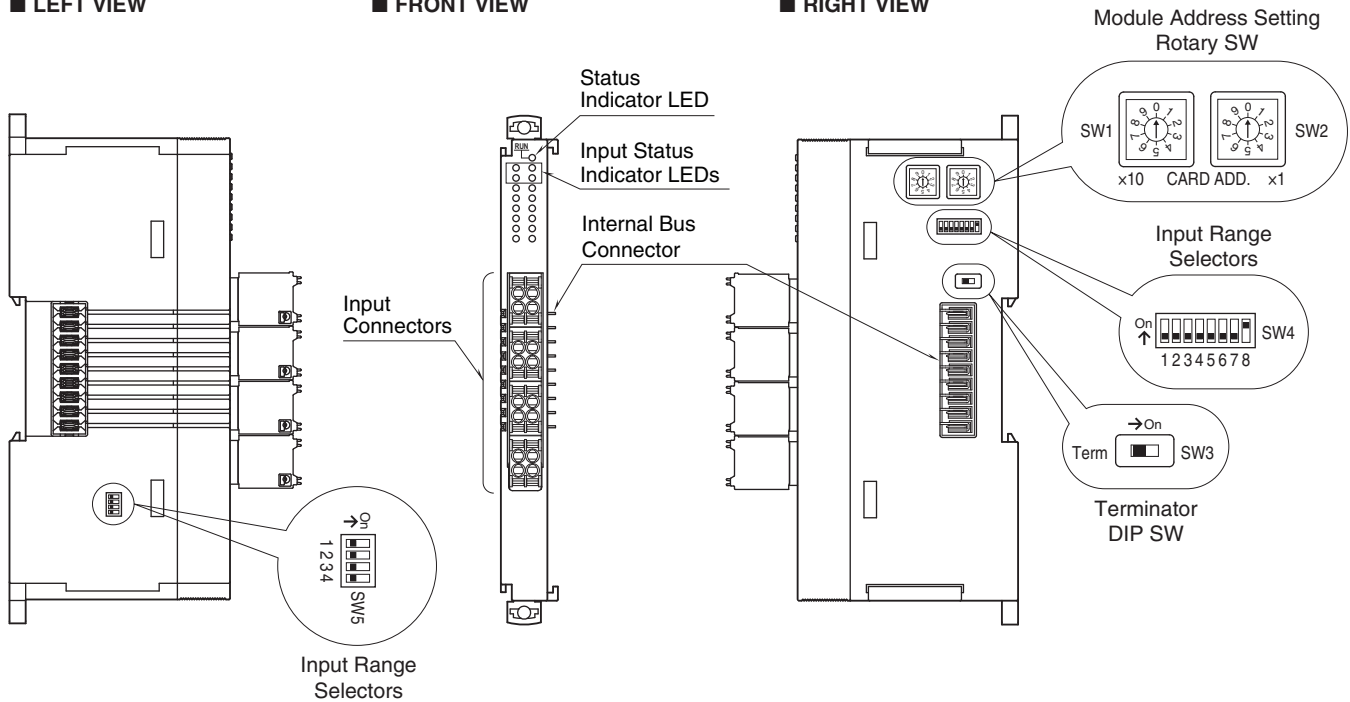

## WIRING

### • TENSION CLAMP

**Unit side connector:** M-System's product

**Cable side connector:** DFMC1,5/2-ST-3,5 (Phoenix Contact)  
(included in the package)

**Applicable wire size:** 0.2 - 1.5 mm<sup>2</sup>

**Stripped length:** 10 mm

### Recommended solderless terminal

- AI0,25-10YE 0.25 mm<sup>2</sup> (Phoenix Contact)
- AI0,34-10TQ 0.34 mm<sup>2</sup> (Phoenix Contact)
- AI0,5-10WH 0.5 mm<sup>2</sup> (Phoenix Contact)
- AI0,75-10GY 0.75 mm<sup>2</sup> (Phoenix Contact)
- A1-10 1.0 mm<sup>2</sup> (Phoenix Contact)
- A1,5-10 1.5 mm<sup>2</sup> (Phoenix Contact)

PIN No.	ID	FUNCTION
1	Ai 1	Input 1 (+)
2	AG	Input 1 (-)
3	24V	Excitation supply (+)
4	0V	Excitation supply (-)
5	Ai 2	Input 2 (+)
6	AG	Input 2 (-)
7	24V	Excitation supply (+)
8	0V	Excitation supply (-)
9	Ai 3	Input 3 (+)
10	AG	Input 3 (-)
11	24V	Excitation supply (+)
12	0V	Excitation supply (-)
13	Ai 4	Input 4 (+)
14	AG	Input 4 (-)
15	24V	Excitation supply (+)
16	0V	Excitation supply (-)

## OPERATING MODE SETTING

(\*) factory default setting

Note: Be sure to set unused SW4-5 through 4-7 to OFF.

### ■ Module Address

The left switch determines the tenth place digit, while the right one does the ones place digit of the module address. Address is selected between 0 to 30.

(Factory setting: 0)

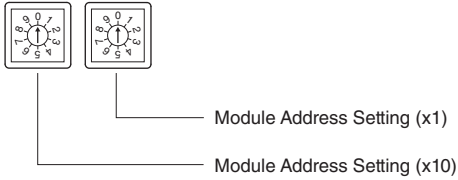

### ■ Terminator DIP SW

TERMINATOR SW	SW3
Without (*)	OFF
With	ON

### ■ Input Setting

INPUT SETTING		INPUT 1		INPUT 2		INPUT 3		INPUT 4		MODE
		SW4-1	SW5-1	SW4-2	SW5-2	SW4-3	SW5-3	SW4-4	SW5-4	SW4-8
Configuration mode	Voltage input (*)	OFF	OFF	OFF	OFF	OFF	OFF	OFF	OFF	ON
	Current input	OFF	ON	OFF	ON	OFF	ON	OFF	ON	ON
Fixed input mode	Voltage input 0 – 10V DC	OFF	OFF	OFF	OFF	OFF	OFF	OFF	OFF	OFF
	Current input 4 – 20mA DC	ON	ON	ON	ON	ON	ON	ON	ON	OFF

## EXTERNAL DIMENSIONS unit: mm (inch)

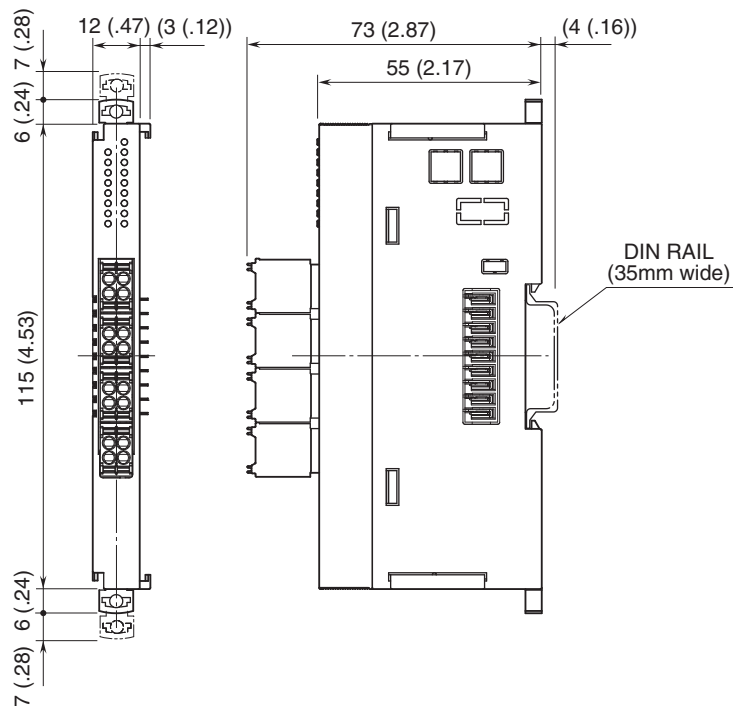

**SCHEMATIC CIRCUITRY & CONNECTION DIAGRAM**

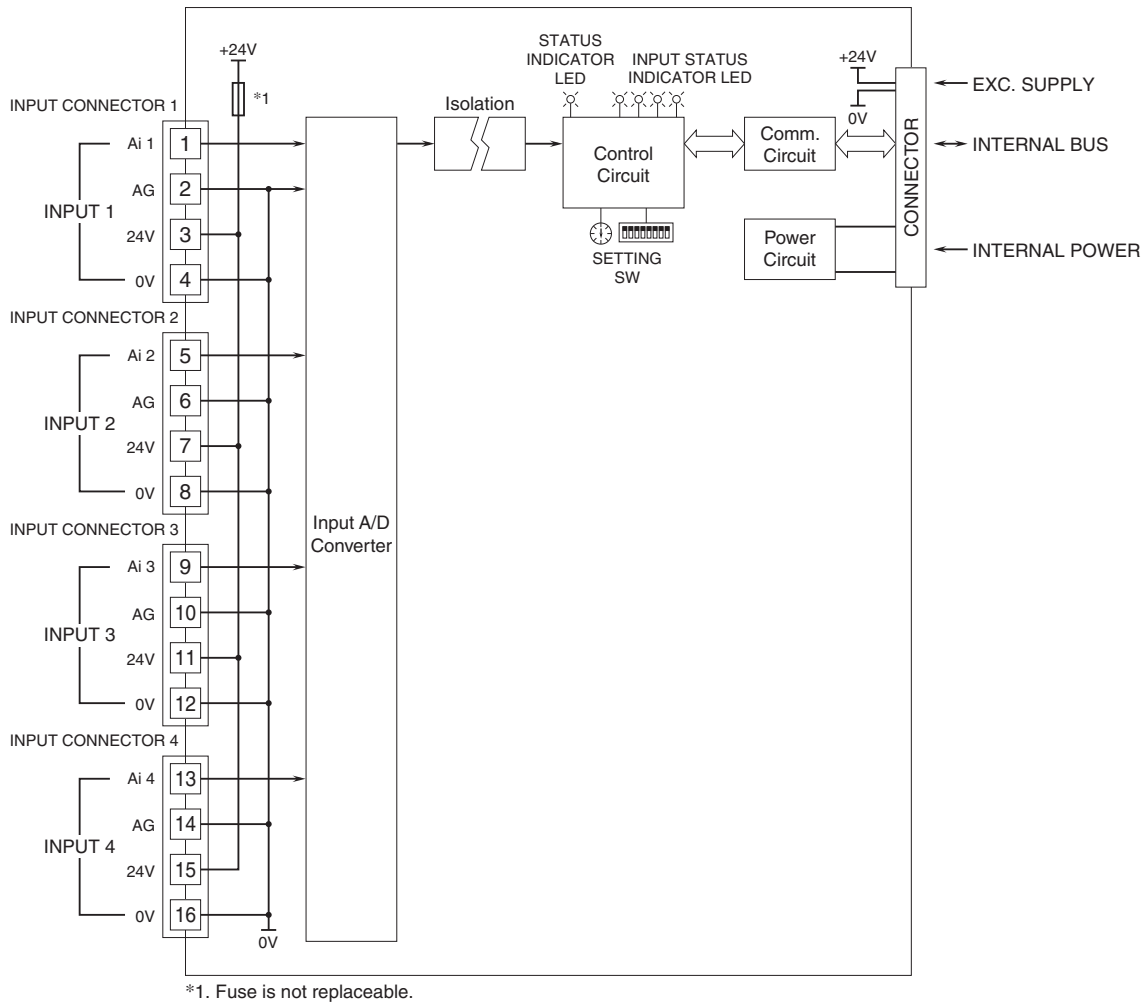

Specifications are subject to change without notice.