

**isc Silicon NPN Power Transistor**

**BU408**

**DESCRIPTION**

- High Voltage:  $V_{CEV} = 400V(\text{Min})$
- Fast Switching Speed-  
:  $t_f = 400ns(\text{Max})$
- Low Saturation Voltage-  
:  $V_{CE(\text{sat})} = 1.0V(\text{Max}) @ I_C = 6A$

**APPLICATIONS**

- Designed for use in horizontal deflection output stages of TV's and CRT's

**ABSOLUTE MAXIMUM RATINGS( $T_a = 25^\circ\text{C}$ )**

SYMBOL	PARAMETER	VALUE	UNIT
$V_{CBO}$	Collector-Base Voltage	400	V
$V_{CEV}$	Collector-Emitter Voltage	400	V
$V_{CEO}$	Collector-Emitter Voltage	200	V
$V_{EBO}$	Emitter-Base Voltage	6	V
$I_C$	Collector Current-Continuous	7	A
$I_{CP}$	Collector Current-Peak Repetitive	10	A
$I_{CP}$	Collector Current- Peak (10ms)	15	A
$I_B$	Base Current	4	A
$P_C$	Collector Power Dissipation @ $T_C = 25^\circ\text{C}$	60	W
$T_J$	Junction Temperature	150	$^\circ\text{C}$
$T_{stg}$	Storage Temperature Range	-65~150	$^\circ\text{C}$

**THERMAL CHARACTERISTICS**

SYMBOL	PARAMETER	MAX	UNIT
$R_{th\ j-c}$	Thermal Resistance, Junction to Case	2.08	$^\circ\text{C/W}$
$R_{th\ j-a}$	Thermal Resistance, Junction to Ambient	70	$^\circ\text{C/W}$

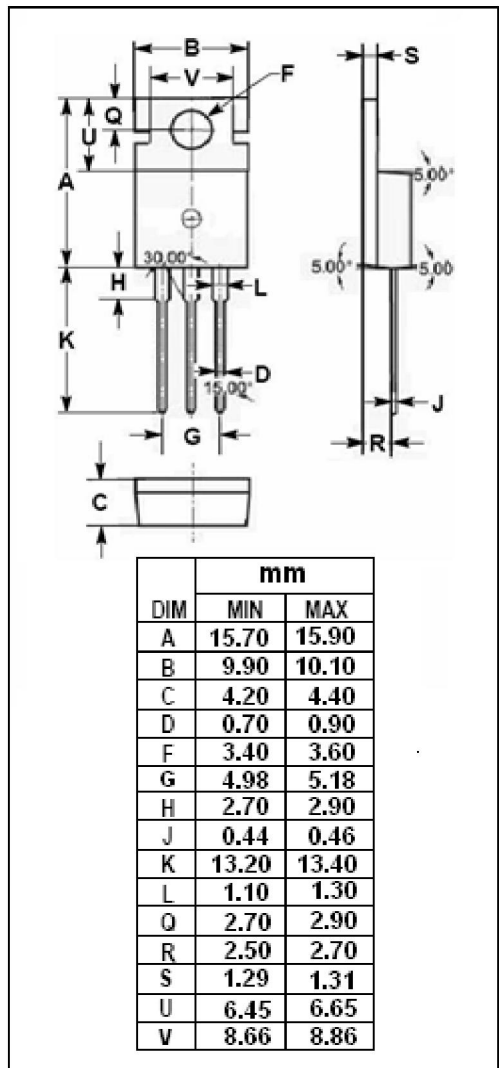
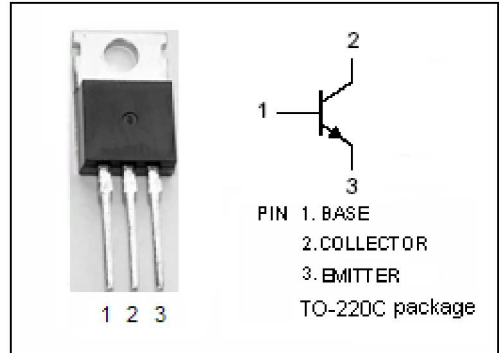

**isc Silicon NPN Power Transistor****BU408****ELECTRICAL CHARACTERISTICS** $T_C=25^{\circ}\text{C}$  unless otherwise specified

SYMBOL	PARAMETER	CONDITIONS	MIN	TYP.	MAX	UNIT
$V_{CEO(SUS)}$	Collector-Emitter Sustaining Voltage	$I_C=100\text{mA}; I_B=0$	200			V
$V_{CE(sat)}$	Collector-Emitter Saturation Voltage	$I_C=6\text{A}; I_B=1.2\text{A}$			1.0	V
$V_{BE(sat)}$	Base-Emitter Saturation Voltage	$I_C=6\text{A}; I_B=1.2\text{A}$			1.2	V
$I_{CES}$	Collector Cutoff Current	$V_{CE}=400\text{V}; V_{BE}=0$ $V_{CE}=250\text{V}; V_{BE}=0$ $V_{CE}=250\text{V}; V_{BE}=0; T_C=150^{\circ}\text{C}$			5.0 0.1 1.0	mA
$I_{EBO}$	Emitter Cutoff Current	$V_{EB}=6\text{V}; I_C=0$			1.0	mA
$f_T$	Current-Gain—Bandwidth Product	$I_C=0.5\text{A}; V_{CE}=10\text{V}$	10			MHz
$t_f$	Fall Time	$I_C=6\text{A}; I_{B1}=-I_{B2}=1.2\text{A}$			0.4	$\mu\text{s}$