

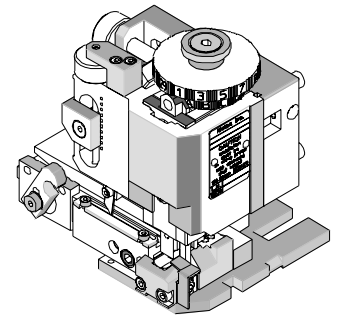

FineAdjust Applicator Specification Sheet Part No. 63863-7100



FEATURES

- Directly adapts to most automatic wire processing machines
- Quick punch removal with the push of a button for fast and easy tooling change
- Applicator designed to industry standard mounting and shut height 135.80mm (5.346")
- Quick set-up time; plus the crimp height, track and feed adjustments can be set without removing the applicator from the press
- Fine adjustment allows users to achieve target with little effort by adjusting in increments of .015mm (.0006") for conductor crimp height and .063mm (.0025") for insulation height
- Independent adjustment rings allow users to quickly adjust the conductor or insulation crimp height without affecting each other

SCOPE

Products: 2.50mm (.098") Board-In Terminal for 22-28 AWG.

Terminal Series No.	Terminal Order No.		Wire Size		Insulation Diameter		Strip Length	
			AWG	mm ²	mm	In.	mm	In.
35044	35044-9103	35044-9360	22-28	0.33-0.08	1.20-1.90	.047-.075	3.00-3.50	.118-.138
	35044-9104	35044-9410						
	35044-9310	35044-9460						

DEFINITION OF TERMS

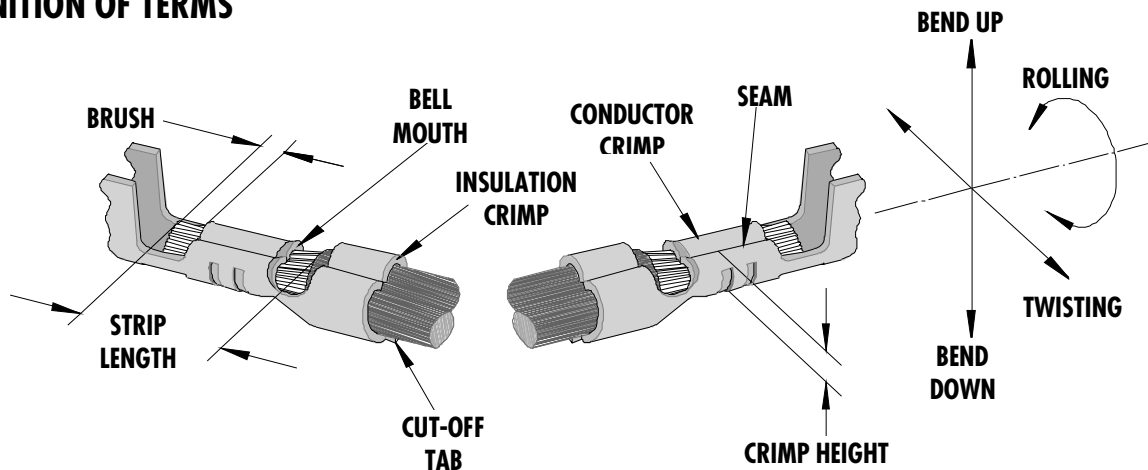

The above terminal drawing is a generic terminal representation. It is not an image of a terminal listed in the scope.

CRIMP SPECIFICATION

Terminal Series No.	Bell mouth		Cut-off Tab Maximum		Conductor Brush	
	mm	In.	mm	In.	mm	In.
35044	0.20-0.50	.008-.020	0.30	.012	0.00-1.40	0.0-.055

Terminal Series No.	Bend up	Bend down	Twist	Roll	Punch Width mm (Ref)				Seam Seam shall not be open and no wire allowed out of the crimping area
	Degree		Degree		Conductor		Insulation		
	mm	In	mm	In	mm	In	mm	In	
35044	3	3	3	3	1.20	.047	1.80	.071	

After crimping, the conductor profile should measure the following.

Terminal Series No.	Wire Size		Conductor			
			Crimp Height		Crimp Width	
	AWG	mm ²	mm	In.	mm	In.
35044	22	0.33	0.83-0.88	.033-.035	1.10-1.30	.043-.051
	24	0.20	0.76-0.81	.030-.032	1.10-1.30	.043-.051
	26	0.13	0.69-0.74	.027-.029	1.10-1.30	.043-.051
	28	0.08	0.66-0.71	.026-.028	1.10-1.30	.043-.051

Terminal Series No.	Wire Size		Insulation				Pull Force Minimum	
			Crimp Height (Max)		Crimp Width			
	AWG	mm ²	mm	In.	mm	In.	N	Lb.
35044	22	0.33	1.70	.067	1.70-1.90	.067-.075	39.2	8.60
	24	0.20	1.70	.067	1.70-1.90	.067-.075	29.4	6.60
	26	0.13	1.70	.067	1.70-1.90	.067-.075	19.6	4.40
	28	0.08	1.70	.067	1.70-1.90	.067-.075	9.8	2.20

Pull Force should be measured with no influence from the insulation crimp.

The above specifications are guidelines to an optimum crimp.

PARTS LIST

FineAdjust Applicator 63863-7100				
Item	Order No	Engineering No.	Description	Quantity
Perishable Tooling				
	63863-7170	63863-7170	Tool Kit (All "Y" Items)	REF
1	63444-1210	63444-1210	Conductor Punch	1 Y
2	63445-1213	63445-1213	Conductor Anvil	1 Y
3	63446-1810	63446-1810	Insulation Punch	1 Y
4	63445-1820	63445-1820	Insulation Anvil	1 Y
5	63443-0003	63443-0003	Cut-Off Plunger	1 Y
6	63443-0012	63443-0012	Front Plunger Retainer	1 Y
Other Components				
7	11-18-4083	60707-8	Front Cover	1
8	11-24-1067	4996-4	Cut-off Plunger Spring	1
9	11-40-4039	8302-5	Front Plunger Striker	1
10	63443-0009	63443-0009	Scrape Chute	1
11	63443-0021	63443-0021	Lower Tooling Key	1
12	63443-2519	63443-2519	Anvil Mount	1
13	63443-4029	63443-4029	Wire Stop	1
14	63443-6001	63443-6001	Rear Cover	1
Frame				
15	63800-4901	63800-4901	Top	1
16	63801-3281	63801-3281	Base	1
17	63801-4650	63801-4650	Track	1
Hardware				
18	N/A	N/A	M3 by 6 Long SHCS	2**
19	N/A	N/A	M4 by 6 Long SHCS	1**
20	N/A	N/A	M4 by 12 Long BHCS	2**
21	N/A	N/A	M4 by 16 Long SHCS	1**
22	N/A	N/A	M4 by 20 Long SHCS	1**
23	N/A	N/A	M4 by 50 Long SHCS	1**
24	N/A	N/A	3mm by 6 Long Roll Pin	1**
25	N/A	N/A	#10-32 by 1/4" Long BHCS	1**
** Available from an industrial supply company such as MSC (1-800-645-7270).				

Assembly Drawing

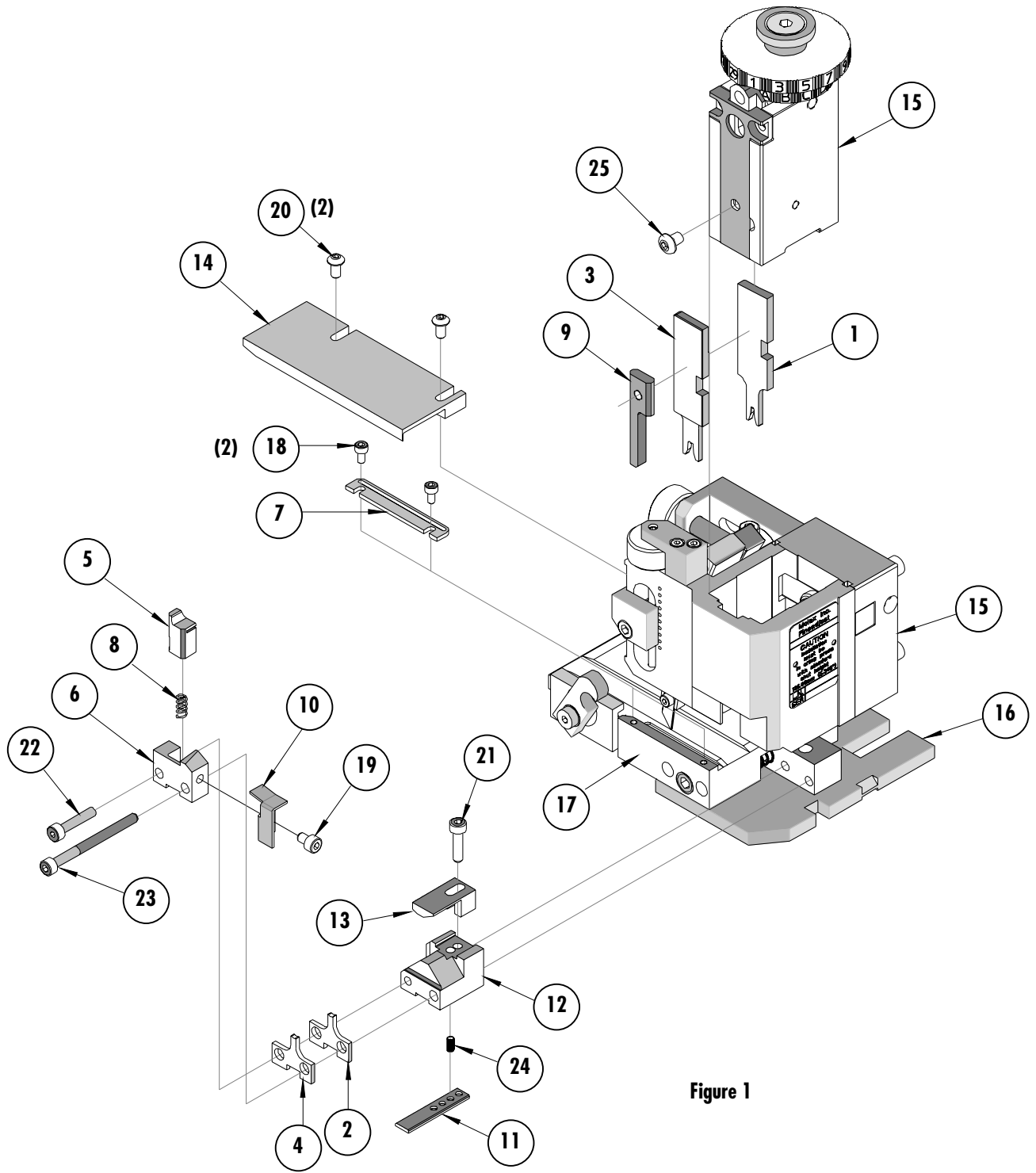

Figure 1

NOTES

1. Molex recommends an extra perishable tooling kit be maintained at your facility.
2. Verify tooling alignment by manually cycling the press and Applicator before crimping under power. Check that all screws are tight.
3. Slugs, Terminals, Dirt and Oil should be kept clear of work area.
4. Wear safety glasses at all times.
5. For recommended maintenance refer to the FineAdjust Manual.

CAUTION: This applicator should only be used in a press with a shut height of 135.8mm (5.346"). Tooling damage could result at a lower setting.

CAUTION: To prevent injury never operate this Applicator without the guards supplied with the press or wire-processing machine in place. Reference the press or wire processing manufacturer's instruction manual.

CAUTION: Molex crimp specifications are valid only when used with Molex terminals, applicators and tooling.

Americas Headquarters

Lisle, Illinois 60532 U.S.A.
1-800-78MOLEX
amerinfo@molex.com

Far East North Headquarters

Yamato, Kanagawa, Japan
81-462-65-2324
feninfo@molex.com

Far East South Headquarters

Jurong, Singapore
65-6-268-6868
fesinfo@molex.com

European Headquarters

Munich, Germany
49-89-413092-0
eurinfo@molex.com

Corporate Headquarters

2222 Wellington Ct.
Lisle, IL 60532 U.S.A.
630-969-4550
Fax: 630-969-1352

Visit our Web site at <http://www.molex.com>