



Size: 0.77in x 0.50in x 0.39in (19.5mm x 12.5mm x 9.8mm)

OPTIONS

- 8kVDC Reinforced Isolation
- Output Voltage
- Input Voltage
- Single or Dual output

FEATURES

- 5, 12, 15, & 24VDC Nominal Input Voltages
- 1 Watt Output Power
- RoHS Compliant
- No Minimum Load Requirement
- Non-Regulated Single and Dual Outputs
- 7-Pin SIP Package: 0.77" x 0.50" x 0.39"
- High Efficiency up to 82%
- -40°C to +85°C Operating Temperature Range
- 6.4KVDC I/O Isolation
- Optional 8KVDC I/O Isolation Available (Suffix "H8")
- MTBF: 2,000,000 hours
- IEC 60950-1, EN 60950-1, IEC 60601-1 and EN 60601-1 Medical Approvals

APPLICATIONS

- Battery Operated Equipment
- Measurement Equipment
- Telecom
- Wireless Networks
- Industry Control Systems

DESCRIPTION

The DCHBA1 series of isolated medical DC/DC power converters provides 1 Watt of continuous output power in a 0.77" x 0.50" x 0.39" 7-pin SIP package. This series consists of non-regulated single and dual output models with 5, 12, 15, and 24VDC nominal input voltages. Some features include high efficiency up to 82%, 6.4KVDC I/O isolation (8KVDC optional), -40°C to +85°C operating temperature range, and no minimum load requirement. The DCHBA1 series is RoHS and UL94V-0 compliant. These converters have IEC 60950-1, EN 60950-1, IEC 60601-1 and EN 60601-1 medical approvals and are best suited for use in battery operated equipment, measurement equipment, telecom, wireless networks, industry control systems, and anywhere where isolated and compact size are required.

MODEL SELECTION TABLE

Single Output Models

Model Number ⁽¹⁾	Input Voltage Range	Output Voltage	Output Current @ Full Load	Ripple & Noise	Input Current		Output Power	Maximum Capacitive Load ⁽²⁾	Efficiency ⁽³⁾
					No Load	Full Load			
DCHBA1-5S33H6	5VDC (4.5~5.5VDC)	3.3VDC	303mA	150mVp-p Max.	35mA	278mA	1W	3300µF	76%
DCHBA1-5S05H6		5VDC	200mA			271mA		2200µF	78%
DCHBA1-5S72H6		7.5VDC	140mA			273ma		1000µF	78%
DCHBA1-5S09H6		9VDC	111mA			263mA		1000µF	80%
DCHBA1-5S12H6		12VDC	84mA			262mA		470µF	81%
DCHBA1-5S15H6		15VDC	66mA			253mA		470µF	82%
DCHBA1-12S33H6	12VDC (10.8~13.2VDC)	3.3VDC	303mA	150mVp-p Max.	30mA	116mA	1W	3300µF	76%
DCHBA1-12S05H6		5VDC	200mA			113mA		2200µF	78%
DCHBA1-12S72H6		7.5VDC	140mA			114mA		1000µF	78%
DCHBA1-12S09H6		9VDC	111mA			110mA		1000µF	80%
DCHBA1-12S12H6		12VDC	84mA			110mA		470µF	81%
DCHBA1-12S15H6		15VDC	66mA			106mA		470µF	82%

DCHBA1-15S33H6	15VDC (13.5~16.5VDC)	3.3VDC	303mA	150mVp-p Max.	25mA	93mA	1W	3300µF	76%
DCHBA1-15S05H6		5VDC	200mA			91mA		2200µF	78%
DCHBA1-15S72H6		7.5VDC	140mA			91mA		1000µF	78%
DCHBA1-15S09H6		9VDC	111mA			88mA		1000µF	80%
DCHBA1-15S12H6		12VDC	84mA			88mA		470µF	81%
DCHBA1-15S15H6		15VDC	66mA			85mA		470µF	82%
DCHBA1-24S33H6	24VDC (21.6~26.4VDC)	3.3VDC	303mA	150mVp-p Max.	20mA	58mA	1W	3300µF	76%
DCHBA1-24S05H6		5VDC	200mA			57mA		2200µF	78%
DCHBA1-24S72H6		7.5VDC	140mA			57mA		1000µF	78%
DCHBA1-24S09H6		9VDC	111mA			54mA		1000µF	80%
DCHBA1-24S12H6		12VDC	84mA			55mA		470µF	81%
DCHBA1-24S15H6		15VDC	66mA			53mA		470µF	82%

Dual Output Models									
Model Number	Input Voltage Range	Output Voltage	Output Current	Ripple & Noise	Input Current		Output Power	Maximum Capacitive Load	Efficiency
					No Load	Full Load			
DCHBA1-5D33H6	5VDC (4.5~5.5VDC)	±3.3VDC	±151mA	150mVp-p	35mA	281mA	1W	±2200µF	75%
DCHBA1-5D05H6		±5VDC	±100mA			271mA		±1000µF	78%
DCHBA1-5D72H6		±7.2VDC	±70mA			273mA		±470µF	78%
DCHBA1-5D09H6		±9VDC	±55mA			264mA		±470µF	79%
DCHBA1-5D12H6		±12VDC	±41mA			259mA		±220µF	80%
DCHBA1-5D15H6		±15VDC	±33mA			258mA		±220µF	81%
DCHBA1-12D33H6	12VDC (10.8~13.2VDC)	±3.3VDC	±151mA	150mVp-p	30mA	117mA	1W	±2200µF	75%
DCHBA1-12D05H6		±5VDC	±100mA			113mA		±1000µF	78%
DCHBA1-12D72H6		±7.2VDC	±70mA			114mA		±470µF	78%
DCHBA1-12D09H6		±9VDC	±55mA			110mA		±470µF	79%
DCHBA1-12D12H6		±12VDC	±41mA			108mA		±220µF	80%
DCHBA1-12D15H6		±15VDC	±33mA			108mA		±220µF	81%
DCHBA1-15D33H6	15VDC (13.5~16.5VDC)	±3.3VDC	±151mA	150mVp-p	25mA	94mA	1W	±2200µF	75%
DCHBA1-15D05H6		±5VDC	±100mA			91mA		±1000µF	78%
DCHBA1-15D72H6		±7.2VDC	±70mA			91mA		±470µF	78%
DCHBA1-15D09H6		±9VDC	±55mA			88mA		±470µF	79%
DCHBA1-15D12H6		±12VDC	±41mA			87mA		±220µF	80%
DCHBA1-15D15H6		±15VDC	±33mA			86mA		±220µF	81%
DCHBA1-24D33H6	24VDC (21.6~26.4VDC)	±3.3VDC	±151mA	150mVp-p	20mA	59mA	1W	±2200µF	75%
DCHBA1-24D05H6		±5VDC	±100mA			57mA		±1000µF	78%
DCHBA1-24D72H6		±7.2VDC	±70mA			57mA		±470µF	78%
DCHBA1-24D09H6		±9VDC	±55mA			55mA		±470µF	79%
DCHBA1-24D12H6		±12VDC	±41mA			54mA		±220µF	80%
DCHBA1-24D15H6		±15VDC	±33mA			54mA		±220µF	81%

SPECIFICATIONS								
<p>All specifications are based on 25°C, Nominal Input Voltage, and Maximum Output Current unless otherwise noted. We reserve the right to change specifications based on technological advances.</p>								
SPECIFICATION	TEST CONDITIONS			Min	Typ	Max	Unit	
INPUT SPECIFICATIONS								
Input Voltage Range	5VDC nominal input models			4.5	5	5.5	V	
	12VDC nominal input models			10.8	12	13.2		
	15VDC nominal input models			13.5	15	16.5		
	24VDC nominal input models			21.6	24	26.4		
Input Filter				Capacitor				
OUTPUT SPECIFICATIONS								
Output Voltage				See Table				
Voltage Accuracy	Nominal Vin and Full Load					±5	%	
Line Regulation	For Vin change of 1%					±1.5	%	
Load Regulation	10% Load to Full Load			3.3V & 5V Models			15	%
				All other models			10	

Voltage Balance	Dual Output			1	%
Output Power				1	W
Output Current		See Table			
Minimum Load		0			A
Maximum Capacitive Load		See Table			
Ripple & Noise (20MHz bandwidth)				150	mVp-p
PROTECTION					
Short Circuit Protection		1 Second			
ENVIRONMENTAL SPECIFICATIONS					
Operating Case Temperature		-40		+85	°C
Storage Temperature		-55		+125	°C
Maximum Case Temperature				+95	°C
Relative Humidity				95	% RH
Reliability, calculated MTBF			2,000,000		Hours

SPECIFICATIONS						
All specifications are based on 25°C, Nominal Input Voltage, and Maximum Output Current unless otherwise noted. We reserve the right to change specifications based on technological advances.						
SPECIFICATION	TEST CONDITIONS		Min	Typ	Max	Unit
GENERAL SPECIFICATIONS						
Efficiency	Nominal Input and Full Load		See Table			
Switching Frequency					80	kHz
Isolation Voltage	Input to Output	Test duration 1 second		6400		VDC
Isolation Resistance	500VDC		15			GΩ
Isolation Capacitance					10	pF
PHYSICAL SPECIFICATIONS						
Weight			0.15oz (4.3g) typ.			
Dimensions (L x W x H)			0.77in x 0.50in x 0.39in (19.5mm x 12.5mm x 9.8mm)			
Case Material			Plastic (UL94 V-0)			
Potting Material			Epoxy (UL94 V-0)			
SAFETY & EMC CHARACTERISTICS						
Safety Approvals			IEC 60950-1 EN 60950-1 IEC 60601-1 EN60601-1			

NOTES	
(1)	For 8KVDC I/O isolation replace the "H6" suffix in the model number with "H8" (Ex. DCHBA1-12S12H8)
(2)	For each output.
(3)	Typical value tested at nominal input and full load

MECHANICAL DRAWINGS

Single Output Models

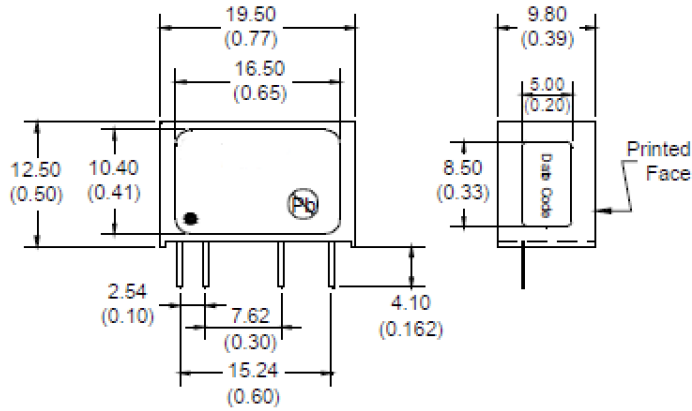

Pin	Single	Dual
1	+Vin	+Vin
2	-Vin	-Vin
5	-Vout	-Vout
6	No Pin	Common
7	+Vout	+Vout

Unit: mm
Tolerance: XX.XX ±0.25 (±0.01)

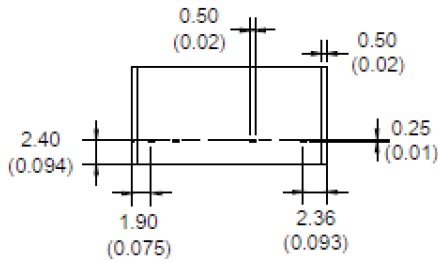

Dual Output Models

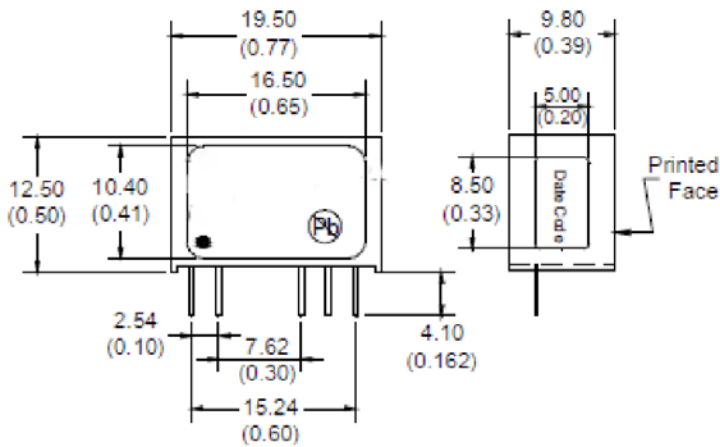

Pin	Single	Dual
1	+Vin	+Vin
2	-Vin	-Vin
5	-Vout	-Vout
6	No Pin	Common
7	+Vout	+Vout

Unit: mm
Tolerance: XX.XX ±0.25 (±0.01)

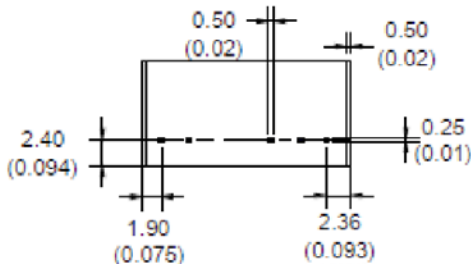

TEST CONFIGURATIONS

All specifications are based on 25°C, Nominal Input Voltage, and Maximum Output Current unless otherwise noted.
We reserve the right to change specifications based on technological advances.

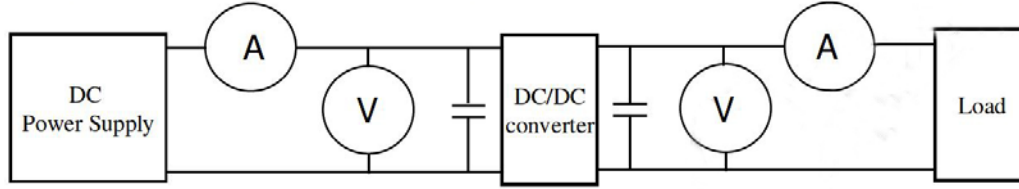

DC Power Supply: offers a wide voltage and current range precisely.
 Current Meter (A): Accuracy → 200μA~200mA 4 ranges ±(0.2% rdg + 2 digits)
 2000mA~20A 2 ranges ±(0.3% rdg + 2 digits)
 Voltage Meter (V): Accuracy → ±(0.3% rdg + 4 digits)
 Load: At Full Load
 Wires: The resistance of the wires must be small.

1. Input Voltage Range: Narrow input voltage range (±10%); Wide input voltage range (2:1 and 4:1)

Ex: Narrow input voltage range (±10%)
 5VDC nominal input → 4.5~5.5VDC
 12VDC nominal input → 10.8~13.2VDC
 24VDC nominal input → 21.6~26.4VDC

Wide input voltage range 2:1
 5VDC nominal input → 4.5~9VDC
 12VDC nominal input → 9~18VDC
 24VDC nominal input → 18~36VDC
 48VDC nominal input → 36~75VDC

Wide input voltage range 4:1 (W)
 24VDC nominal input → 9~36VDC
 48VDC nominal input → 18~75VDC

2. Input Power:

$$P_{in} = V_{in} \times I_{in}$$

V_{in} : Input voltage
 I_{in} : Input current

3. Output Power:

$$P_{out} = V_{out} \times I_{out}$$

V_{out} : Output Voltage
 I_{out} : Output Current

4. Efficiency:

$$\text{Efficiency} = \frac{P_{out}}{P_{in}} \times 100\%$$

P_{out} : Output Power
 P_{in} : Input Power

5. Voltage Accuracy:

$$\frac{|V_{out} - V_{out(Nominal)}|}{V_{out}} \times 100\%$$

V_{out} : Output Voltage
 $V_{out (nominal)}$: Nominal output voltage

6. Line Regulation:

(1) Wide input voltage range and regulated output voltage series

$$\frac{|V_{out(LL)} - V_{out(HL)}|}{V_{out(LL)}} \times 100\%$$

LL: Low Line Input Voltage
HL: High Line Input Voltage

(2) Narrow input voltage range (±10%) and unregulated output voltage series

$$\text{Line Regulation} = \left| \frac{\Delta V_{out}}{\Delta V_{in}} \right|$$

$$\Delta V_{out} = \frac{V_{in(+10\%)} - V_{in(-10\%)}}{10\%} \times 100\%$$

$V_{out(+10\%)}$: Output Voltage at $V_{in} = 1.1 \times V_{in(nominal)}$ & Full Load

$V_{out(-10\%)}$: Output Voltage at $V_{in} = 0.9 \times V_{in(nominal)}$ & Full Load

V_{out} : Output Voltage at $V_{in} = V_{in(nominal)}$ & Full Load

$$\Delta Vin = \frac{Vin(+10\%) - Vout(-10\%)}{Vin(nominal)} \times 100\%$$

$Vin(+10\%)$: Input Voltage = $1.1 \times Vin(nominal)$
 $Vin(-10\%)$: Input Voltage = $0.9 \times Vin(nominal)$
 $Vin(nominal)$: Nominal Input Voltage

7. Load Regulation:

$$\frac{|Vout(FL) - Vout(NL)|}{Vout(FL)} \times 100\%$$

$Vout(FL)$: Output voltage at Full Load
 $Vout(NL)$: Output voltage at 25% Full Load or 10% Full Load

8. Ripple and Noise: as shown below. The bandwidth is 0-2MHz

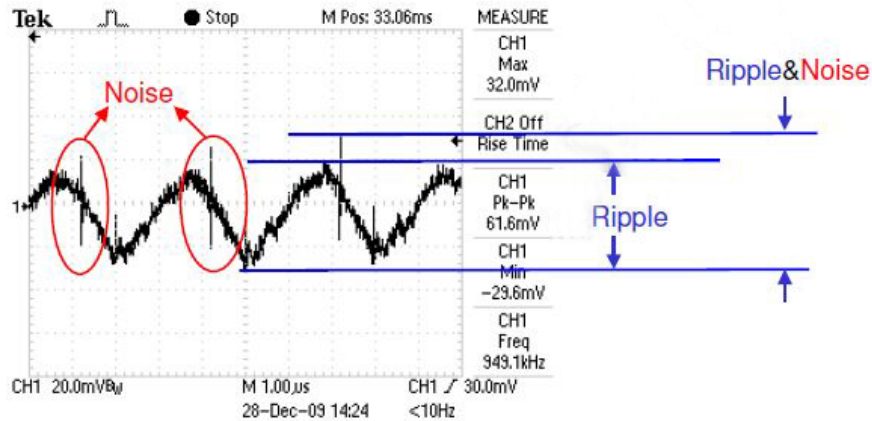

Output Ripple & Noise measurement test circuit: as shown below

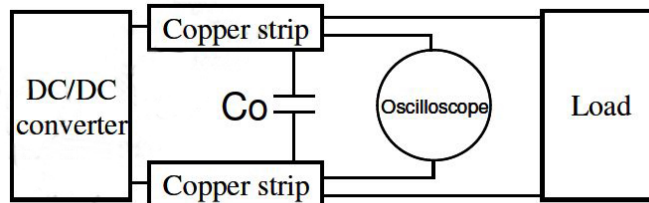

Co : usually 0.47µF.

9. Temperature Derating Curve: The DC/DC converter will operate over a wider temperature range if less power is drawn from the output and the device is already running. The temperature derating curve shows the operating power-temperature range. As shown below.

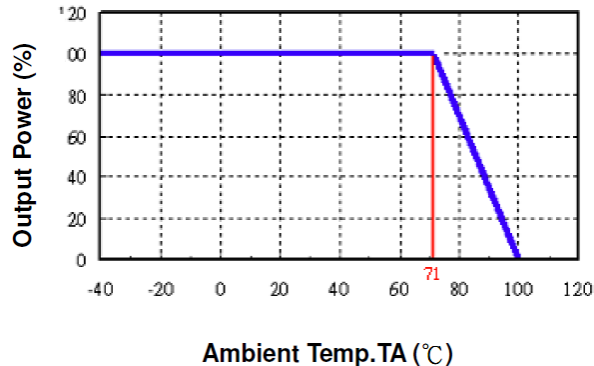

10. Switching Frequency: The nominal operating frequency of the DC/DC converters.

11. Input to Output Isolation: The dielectric breakdown strength test between input and output circuits. This is the isolation voltage the device is capable of withstanding for a specified time, usually 1 second or 1 minute.

COMPANY INFORMATION

Wall Industries, Inc. has created custom and modified units for over 50 years. Our in-house research and development engineers will provide a solution that exceeds your performance requirements on-time and on budget. Our ISO9001-2008 certification is just one example of our commitment to producing a high quality, well-documented product for our customers.

Our past projects demonstrate our commitment to you, our customer. Wall Industries, Inc. has a reputation for working closely with its customers to ensure each solution meets or exceeds form, fit and function requirements. We will continue to provide ongoing support for your project above and beyond the design and production phases. Give us a call today to discuss your future projects.

Contact **Wall Industries** for further information:

Phone: ☎ (603)778-2300
Toll Free: ☎ (888)597-9255
Fax: ☎ (603)778-9797
E-mail: sales@wallindustries.com
Web: www.wallindustries.com
Address: 37 Industrial Drive
Exeter, NH 03833