



The Future of Analog IC Technology®

EV3302DD-00A

1.3A Fixed Frequency White LED Driver Evaluation Board

DESCRIPTION

The EV3302DD-00A is an evaluation board for the MP3302DD, a step-up converter designed for driving up to 27 white LEDs from a single cell lithium ion battery. The EV board is optimized for the load of 3 white LEDs in series, 9 strings panel.

The MP3302 uses current mode, fixed frequency architecture to regulate the LED current, which is measured through an external current sense resistor. Its low 195mV feedback voltage reduces power loss and improves efficiency. The MP3302 monitors the output voltage and turns off the converter if an over-voltage condition is present due to an open circuit condition.

The MP3302 includes under-voltage lockout, current limiting and thermal overload protection preventing damage in the event of an output overload.

The MP3302 is available in small 8-pin QFN (2mm x 3mm) package.

ELECTRICAL SPECIFICATIONS

Parameter	Symbol	Value	Units
Input Voltage	V_{IN}	3.3 – 6	V
Number of LEDs		27	

FEATURES

- 3.3V to 6V Input Voltage Range
- Drives up to 27 White LEDs
- Up to 87% Efficiency
- Open Load Shutdown
- Fully Assembled and Tested

APPLICATIONS

- Cell Phones
- Handheld Computers and PDAs
- Digital Still Cameras
- Small LCD Displays

"MPS" and "The Future of Analog IC Technology" are Registered Trademarks of Monolithic Power Systems, Inc.

EV3302DD-00A EVALUATION BOARD



(L x W x H) 1.8" x 1.8" x 0.4"
4.6cm x 4.6cm x 1.0cm

Board Number	MPS IC Number
EV3302DD-00A	MP3302DD

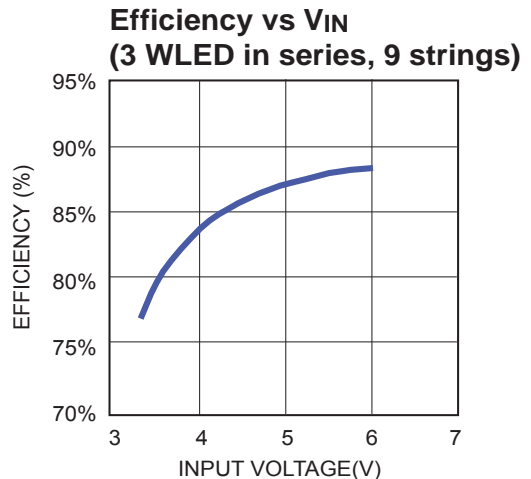

EVALUATION BOARD SCHEMATIC

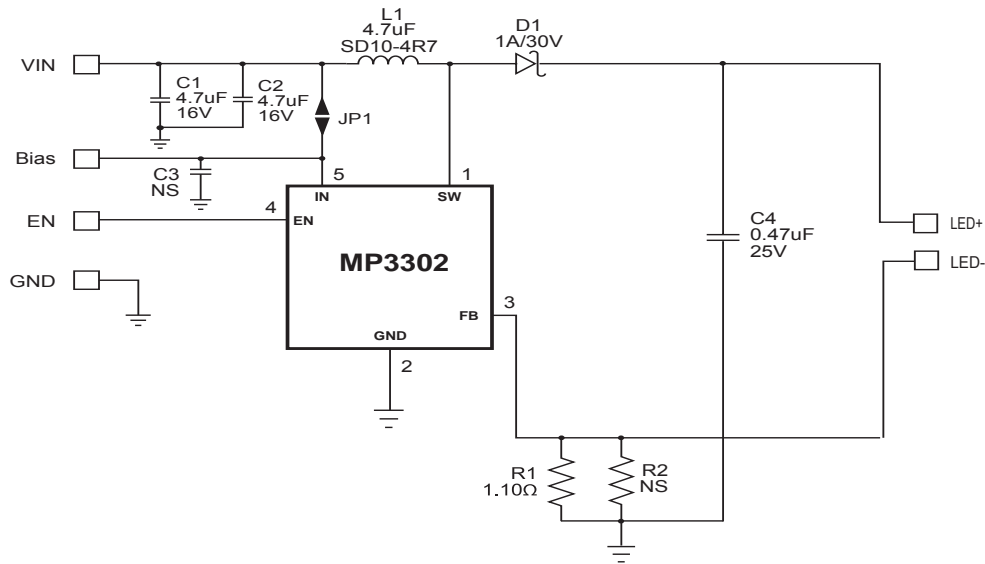

EV3302DD-00A BILL OF MATERIALS

Qty	Ref	Value	Description	Package	Manufacturer	Part Number
2	C1,C2	4.7µF	Ceramic Capacitor, 16V, X5R	0805	Murata	GRM21BR61C475KA88
1	C3	NS	Not Stuffed			
1	C4	0.47µF	Ceramic Capacitor, 25V, X7R	0805	Murata	GRM21BR71E474KA01L
1	D1		Diode Schottky, 30V, 1A	SMA	Diodes Inc	DFLS130L-F
1	L1	4.7µH	Inductor, 1.1A	SMD	Cooper	SD10-4R7-R
1	R1	1.10Ω	Resistor, 1%	0805	Yageo	R0805FR-071R1L
1	R2	NS	Not Stuffed			
1	U1		White Led Driver	QFN8	MPS	MP3302DD
1	CN1		Connector		JST	SM02B-BHSS-1-TB

PRINTED CIRCUIT BOARD LAYOUT

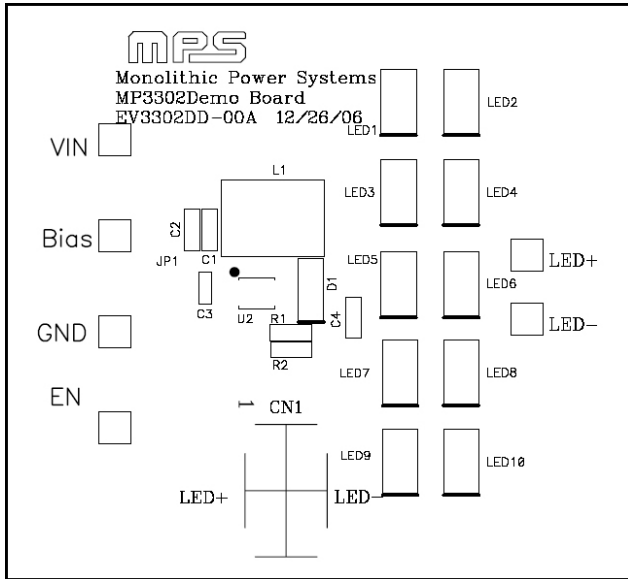

Figure 1—Top Silk Layer

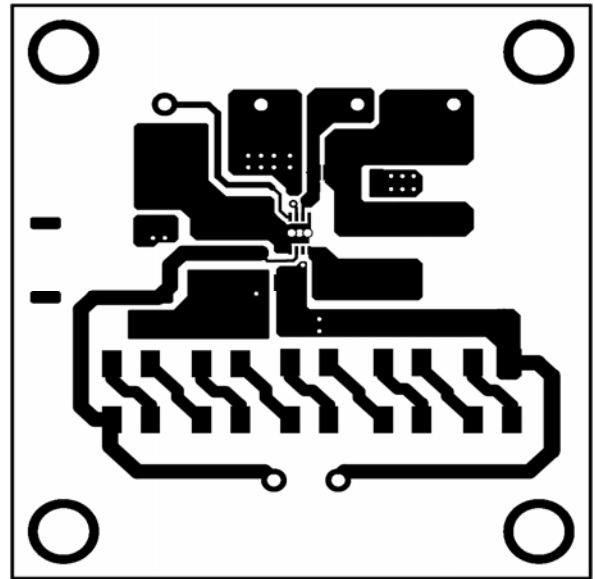

Figure 2—Top Layer

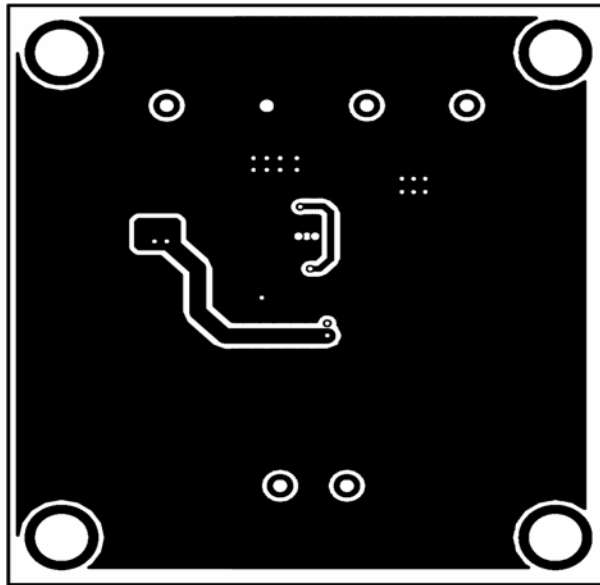

Figure 3—Bottom Layer

QUICK START GUIDE

1. Connect the positive and negative terminals of the load panel (3 white LEDs in series, 9 strings paralleled, each string have a 43ohm droop resistor) to the LED+ and LED- pins on the EV board, respectively.
2. Connect the positive and negative terminals of the power supply (3.3V ~ 6V) to the VIN and GND pins on the EV board, respectively. Turn the power supply on.
3. Drive EN pin high ($1.5V < V_{EN} < V_{IN}$) to enable the MP3302.
4. Apply a DC voltage of 0.7V to 1.4V on EN pin for analog dimming. Maximum brightness (180mA typical) occurs with 1.4V voltage applied.
5. For PWM dimming mode, apply a PWM rectangular waveform with a minimum voltage less than 0.5V and a maximum greater than 1.5V on EN pin. The frequency of the PWM signal is recommended between 100Hz to 1kHz.

NOTICE: The information in this document is subject to change without notice. Users should warrant and guarantee that third party Intellectual Property rights are not infringed upon when integrating MPS products into any application. MPS will not assume any legal responsibility for any said applications.