



## VXR100-2800S SERIES

HIGH RELIABILITY COTS DC-DC CONVERTERS



### Models Available

Input: 11 V to 60 V continuous, 9 V to 100 V transient  
 100 W, single output of 3.3 V, 5 V, 7 V, 12 V, 15 V, 18 V  
 -55 °C to 105 °C Operation

## 1.0 DESCRIPTION

The VXR series of isolated DC-DC converters is the latest and most advanced offering in VPT's extensive line of high reliability COTS products. Building on a proven design heritage, the VXR series features high efficiency, an ultra-wide input voltage range, and next-generation packaging. Providing a wide 9 V to 60 V input, along with VPT's standard full feature set and industry-leading performance, the VXR family is optimized for a broad range of applications from military ground vehicles to commercial and military aircraft.

The VXR100 utilizes a low noise, fixed frequency, wide input voltage range topology with extended high and low input transient capability to simplify overall power system design and compliance. Precision controlled synchronous rectification achieves high efficiency over a wide input range, reducing power dissipation and minimizing external heatsink requirements. A proprietary control loop design provides fast transient response without the use of optoisolators.

The VXR Series patent-pending epoxy-encapsulated V-SHIELD® packaging is highly resistant to chemical, solvent and salt environments and is fully compatible with high volume manufacturing processes including wave solder, cleaning solvents, high pressure sprays and aqueous wash processes. A unique integral six-sided metalized shield improves system EMI compatibility. Dual sided conduction cooling coupled with reduced power dissipation simplifies system thermal design.

The VXR series is intended for harsh environments including severe vibration, shock and temperature cycling. Testing is to JESD22, MIL-STD-810, and MIL-STD-883.

## 1.1 FEATURES

- Wide input voltage range: 11 V to 60 V
- Continuous operation at 9 V after 11 V startup
- 9 V to 100 V transient operation
- High Efficiency up to 90%
- Rugged Epoxy Encapsulated V-SHIELD® Package
- Fully compatible with aqueous cleaning processes
- Integral Six-sided Metalized EMI shield
- Dual-Sided Thermal Conduction
- 2000 V Isolation
- Fixed frequency
- Low noise
- Output Voltage Trim (+10% / -20%)
- Output Current Limit Protection
- Short Circuit Protection
- Parallel up to 5 units with current sharing

## 1.2 COMPLIANCE

- MIL-STD-1275 A-E
- RTCA / DO-160-Section 16
- MIL-STD-704 A-F
- MIL-STD-461 C-F when used with an appropriate VXR EMI filter
- RTCA / DO-160-section 18 and 21 when used with an appropriate VXR EMI filter

## 1.3 PACKAGING

- Low-profile: 2.350" x 1.550" x 0.410"
- Max weight: 79 g

## 1.4 SIMILAR PRODUCTS AND ACCESSORIES

- [DVFL](#) 120 W single output Military Qualified DC-DC Converter
- [VPT100](#) 100 W single output metal package COTS DC-DC Converter
- [EMI filters, Thermal Pads, Front-End Modules and Accessories](#)

2.0 DESCRIPTION

2.1 BLOCK DIAGRAM

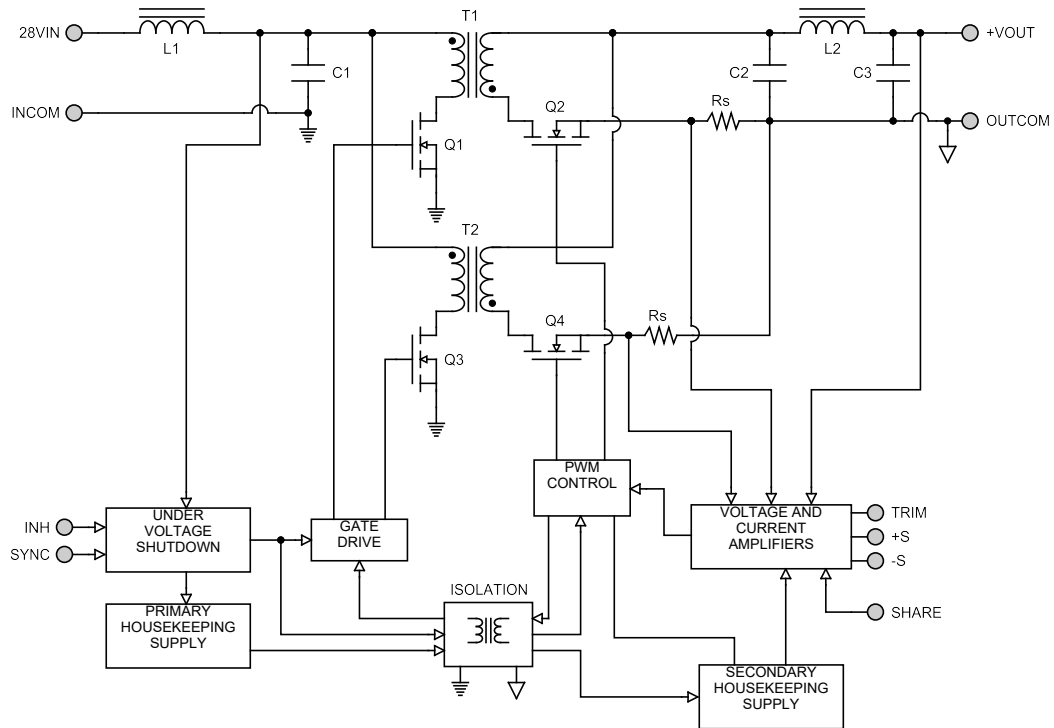

2.2 CONNECTION DIAGRAM

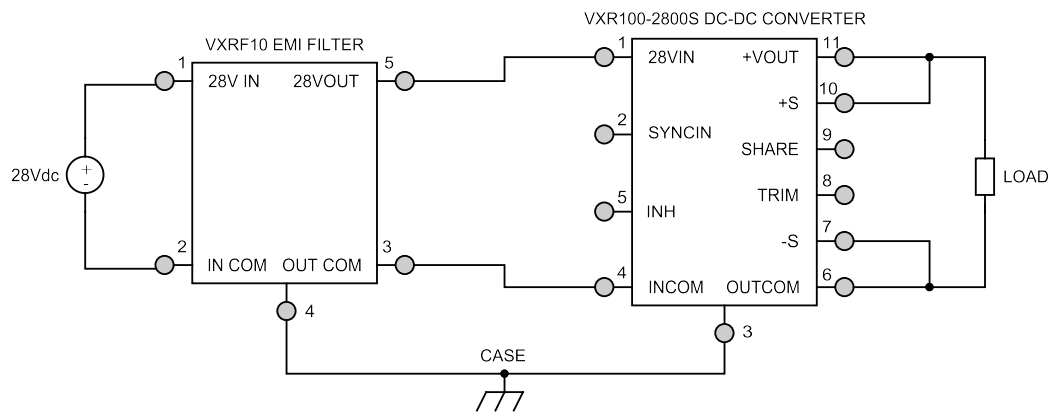

### 3.0 SPECIFICATIONS

#### 3.1 ABSOLUTE MAXIMUM RATINGS

Absolute Maximum Ratings			
Input Voltage (Continuous):	60 V	Operating Temperature (Full Load):	-55 °C to + 105 °C
Input Voltage (Transient, 200 ms):	100 V	Storage Temperature:	-55 °C to + 125 °C
		Lead Solder Temperature (10 seconds):	300 °C

#### 3.2 PERFORMANCE SPECIFICATIONS

Tcase = -55 °C to +105 °C, Vin = +28 V ± 5%, Full Load, Unless Otherwise Specified

Parameter	Conditions	VXR100-283R3S			VXR100-2805S			Units
		Min	Typ	Max	Min	Typ	Max	
<b>INPUT</b>								
Voltage	Continuous	9	28	60	11	28	60	V
	Continuous, Pout ≤ 85 W <sup>3</sup>				9		60	V
	Transient, 200 ms <sup>3</sup>	9	-	100	9	-	100	V
	Transient, 1 sec <sup>3</sup>	9	-	80	9	-	80	V
Current	INH < 0.2 V	-	8	11	-	8	11	mA
	No Load	-	180	270	-	180	270	mA
Ripple Current	20 Hz to 10 MHz	-	35	70	-	40	80	mApp
Undervoltage Lockout	Turn-On	-	-	10.9	-	-	10.9	V
	Turn-Off <sup>3</sup>	-	-	8.9	-	-	8.9	V
<b>OUTPUT STATIC</b>								
Voltage	+Vout, Tcase = 25 °C	3.25	3.3	3.35	4.92	5	5.08	V
	+Vout, Tcase = -55 °C to +105 °C	3.22	3.3	3.38	4.87	5	5.13	V
Power <sup>2</sup>	11 V < Vin < 60 V	0	-	80	0	-	100	W
Power <sup>2</sup>	9 V < Vin < 11 V	0	-	80	0	-	85	W
Current <sup>2</sup>	11 V < Vin < 60 V	0	-	24.2	0	-	20	A
Current <sup>2</sup>	9 V < Vin < 11 V	0	-	24.2	0	-	17	A
Ripple Voltage	20 Hz to 10 MHz	-	40	80	-	40	80	mVpp
Line Regulation	VIN = 11 V to 60 V	-	1	60	-	1	60	mV
Load Regulation	No Load to Full Load	-	1	60	-	1	60	mV
Load Fault Power Dissipation	Overload <sup>3</sup>	-	18	27	-	18	27	W
	Short Circuit <sup>3</sup>	-	13	20	-	13	20	W
<b>OUTPUT DYNAMIC</b>								
Load Step, Half to Full Load	Output Transient	-	260	450	-	230	400	mVpk
	Recovery <sup>1</sup>	-	300	500	-	300	500	µs
Line Step <sup>3</sup> , Vin = 16 V to 40 V	Output Transient	-	150	300	-	100	200	mVpk
	Recovery <sup>1</sup>	-	80	160	-	60	120	µs
Turn-On, Vin = 0 to 28 V	Delay	-	6	10	-	6	10	ms
	Overshoot	-	0	15	-	0	25	mVpk
<b>FUNCTION</b>								
INH Pin Input <sup>3</sup>	Output Inhibited	0	-	0.2	0	-	0.2	V
INH Pin Open Circuit Voltage <sup>3</sup>	Output Enabled	-	3.0	5	-	3.0	5	V
Voltage Trim Range		-12	-	10	-20	-	10	%
SHARE Pin Voltage <sup>3</sup>		1	-	5	1	-	5	V
SYNC Frequency Range		500	-	600	500	-	600	kHz
<b>GENERAL</b>								
Efficiency		81	85	-	83	87	-	%
Capacitive Load <sup>3</sup>		-	-	2000	-	-	2000	µF
Switching Frequency		450	500	550	450	500	550	kHz
Isolation	2000 V DC, Tcase = 25 °C	100	-	-	100	-	-	MΩ
Weight		-	-	79	-	-	79	g
MTBF (MIL-HDBK-217F)	GM @ Tcase = 55 °C	-	541	-	-	541	-	kHr

1. Time for output voltage to settle within 1% of steady-state value

2. Derate linearly to 0 at 115 °C

3. Verified by qualification testing



**3.2 PERFORMANCE SPECIFICATIONS (CONTINUED)**

Tcase = -55 °C to +105 °C, Vin = +28 V ± 5%, Full Load, Unless Otherwise Specified

Parameter	Conditions	VXR100-2807S			VXR100-2812S			Units
		Min	Typ	Max	Min	Typ	Max	
<b>INPUT</b>								
Voltage	Continuous	11	28	60	11	28	60	V
	Continuous, Pout ≤ 85 W <sup>3</sup>	9		60	9		60	V
	Transient, 200 ms <sup>3</sup>	9	-	100	9	-	100	V
	Transient, 1 sec <sup>3</sup>	9	-	80	9	-	80	V
Current	INH < 0.2 V	-	8	11	-	8	11	mA
	No Load	-	200	300	-	200	300	mA
Ripple Current	20 Hz to 10 MHz	-	40	80	-	60	120	mApp
Undervoltage Lockout	Turn-On	-	-	10.9	-	-	10.9	V
	Turn-Off <sup>3</sup>	-	-	8.9	-	-	8.9	V
<b>OUTPUT STATIC</b>								
Voltage	+Vout, Tcase = 25 °C	6.89	7	7.1	11.82	12	12.18	V
	+Vout, Tcase = -55 °C to +105 °C	6.82	7	7.18	11.7	12	12.3	V
Power <sup>2</sup>	11 V < Vin < 60 V	0	-	100	0	-	100	W
Power <sup>2</sup>	9 V < Vin < 11 V	0	-	85	0	-	85	W
Current <sup>2</sup>	11 V < Vin < 60 V	0	-	14.3	0	-	8.3	A
Current <sup>2</sup>	9 V < Vin < 11 V	0	-	12.1	0	-	7.1	A
Ripple Voltage	20 Hz to 10 MHz	-	40	80	-	25	70	mVpp
Line Regulation	VIN = 11 V to 60 V	-	1	60	-	1	60	mV
Load Regulation	No Load to Full Load	-	1	60	-	1	60	mV
Load Fault Power Dissipation	Overload <sup>3</sup>	-	12	21	-	20	30	W
	Short Circuit <sup>3</sup>	-	7	14	-	13	25	W
<b>OUTPUT DYNAMIC</b>								
Load Step, Half to Full Load	Output Transient	-	170	350	-	580	800	mVpk
	Recovery <sup>1</sup>	-	200	400	-	200	400	µs
Line Step <sup>3</sup> , Vin = 16 V to 40 V	Output Transient	-	130	220	-	350	650	mVpk
	Recovery <sup>1</sup>	-	60	120	-	150	250	µs
Turn-On, Vin = 0 to 28 V	Delay	-	6	10	-	6	10	ms
	Overshoot	-	0	25	-	0	50	mVpk
<b>FUNCTION</b>								
INH Pin Input <sup>3</sup>	Output Inhibited	0	-	0.2	0	-	0.2	V
INH Pin Open Circuit Voltage <sup>3</sup>	Output Enabled	-	3.0	5	-	3.0	5	V
Voltage Trim Range		-20	-	10	-20	-	10	%
SHARE Pin Voltage <sup>3</sup>		1	-	5	1	-	5	V
SYNC Frequency Range		500	-	600	500	-	600	kHz
<b>GENERAL</b>								
Efficiency		87	89	-	83	87	-	%
Capacitive Load <sup>3</sup>		-	-	2000	-	-	1000	µF
Switching Frequency		450	500	550	450	500	550	kHz
Isolation	2000 V DC, Tcase = 25 °C	100	-	-	100	-	-	MΩ
Weight		-	-	79	-	-	79	g
MTBF (MIL-HDBK-217F)	GM @ Tcase = 55 °C	-	541	-	-	541	-	kHr

- 1. Time for output voltage to settle within 1% of steady-state value
- 2. Derate linearly to 0 at 115 °C
- 3. Verified by qualification testing

### 3.2 PERFORMANCE SPECIFICATIONS (CONTINUED)

Tcase = -55 °C to +105 °C, Vin = +28 V ± 5%, Full Load, Unless Otherwise Specified

Parameter	Conditions	VXR100-2815S			VXR100-2818S			Units
		Min	Typ	Max	Min	Typ	Max	
<b>INPUT</b>								
Voltage	Continuous	11	28	60	11	28	60	V
	Continuous, Pout ≤ 85 W <sup>3</sup>	9		60	9		60	V
	Transient, 200 ms <sup>3</sup>	9	-	100	9	-	100	V
	Transient, 1 sec <sup>3</sup>	9	-	80	9	-	80	V
Current	INH < 0.2 V	-	8	11	-	8	11	mA
	No Load	-	200	300	-	250	350	mA
Ripple Current	20 Hz to 10 MHz	-	60	120	-	60	120	mApp
Undervoltage Lockout	Turn-On	-	-	10.9	-	-	10.9	V
	Turn-Off <sup>3</sup>	-	-	8.9	-	-	8.9	V
<b>OUTPUT STATIC</b>								
Voltage	+Vout, Tcase = 25 °C	14.77	15	15.23	17.73	18	18.27	V
	+Vout, Tcase = -55 °C to +105 °C	14.62	15	15.38	17.55	18	18.45	V
Power <sup>2</sup>	11 V < Vin < 60 V	0	-	100	0	-	100	W
Power <sup>2</sup>	9 V < Vin < 11 V	0	-	85	0	-	85	W
Current <sup>2</sup>	11 V < Vin < 60 V	0	-	6.7	0	-	5.6	A
Current <sup>2</sup>	9 V < Vin < 11 V	0	-	5.7	0	-	4.7	A
Ripple Voltage	20 Hz to 10 MHz	-	30	80	-	35	85	mVpp
Line Regulation	VIN = 11 V to 60 V	-	1	60	-	1	60	mV
Load Regulation	No Load to Full Load	-	1	60	-	1	60	mV
Load Fault Power Dissipation	Overload <sup>3</sup>	-	14	21	-	13	20	W
	Short Circuit <sup>3</sup>	-	10	15	-	10	15	W
<b>OUTPUT DYNAMIC</b>								
Load Step, Half to Full Load	Output Transient	-	580	800	-	550	800	mVpk
	Recovery <sup>1</sup>	-	200	400	-	200	400	μs
Line Step <sup>3</sup> , Vin = 16 V to 40 V	Output Transient	-	350	650	-	420	720	mVpk
	Recovery <sup>1</sup>	-	150	250	-	150	250	μs
Turn-On, Vin = 0 to 28 V	Delay	-	6	10	-	6	10	ms
	Overshoot	-	0	50	-	0	50	mVpk
<b>FUNCTION</b>								
INH Pin Input <sup>3</sup>	Output Inhibited	0	-	0.2	0	-	0.2	V
INH Pin Open Circuit Voltage <sup>3</sup>	Output Enabled	-	3.0	5	-	3.0	5	V
Voltage Trim Range		-20	-	10	-20	-	10	%
SHARE Pin Voltage <sup>3</sup>		1	-	5	1	-	5	V
SYNC Frequency Range		500	-	600	500	-	600	kHz
<b>GENERAL</b>								
Efficiency		86	90	-	87	90	-	%
Capacitive Load <sup>3</sup>		-	-	1000	-	-	1000	μF
Switching Frequency		450	500	550	450	500	550	kHz
Isolation	2000 V DC, Tcase = 25 °C	100	-	-	100	-	-	MΩ
Weight		-	-	79	-	-	79	g
MTBF (MIL-HDBK-217F)	GM @ Tcase = 55 °C	-	541	-	-	541	-	kHr

1. Time for output voltage to settle within 1% of steady-state value

2. Derate linearly to 0 at 115 °C

3. Verified by qualification testing

4.0 PERFORMANCE CURVES

4.1.1 VXR100-283R3S Efficiency (Typical, 25 °C)

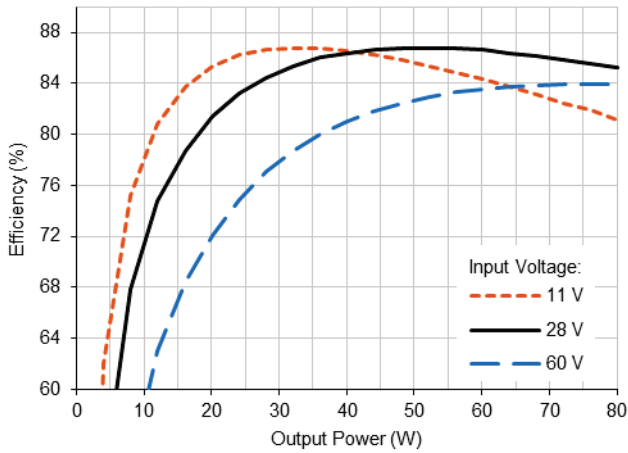

4.1.2 VXR100-2805S Efficiency (Typical, 25 °C)

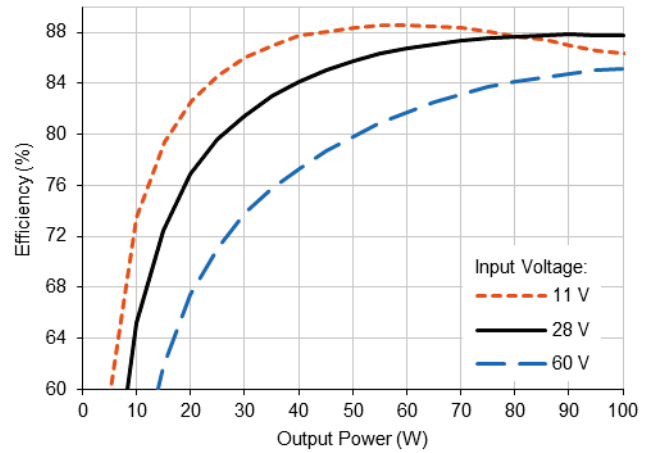

4.1.3 VXR100-2807S Efficiency (Typical, 25 °C)

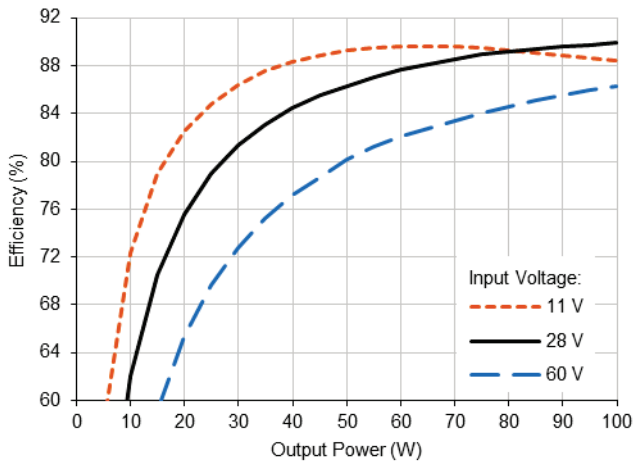

4.1.4 VXR100-2812S Efficiency (Typical, 25 °C)

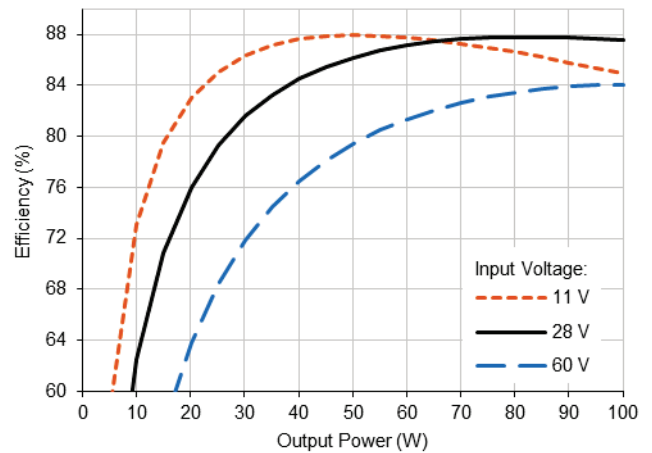

4.1.5 VXR100-2815S Efficiency (Typical, 25 °C)

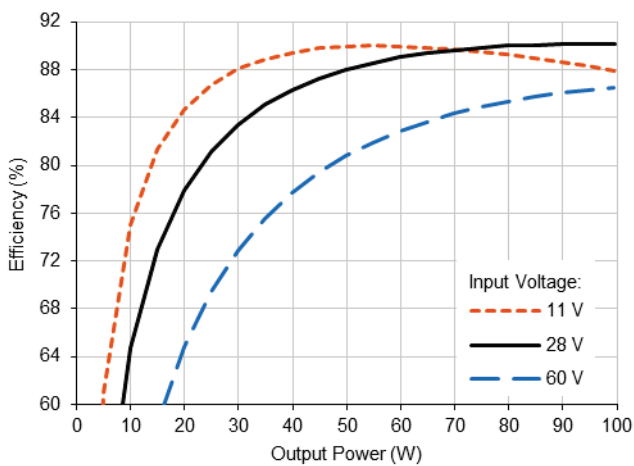

4.1.6 VXR100-2818S Efficiency (Typical, 25 °C)

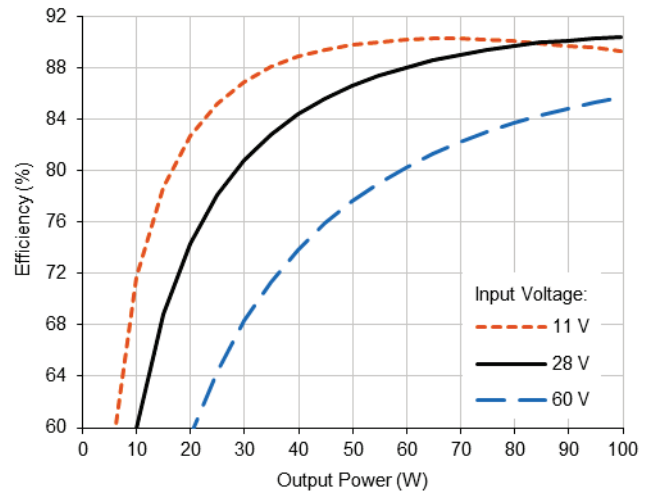

### 5.0 MECHANICAL OUTLINES AND PINOUT

Standard Package:

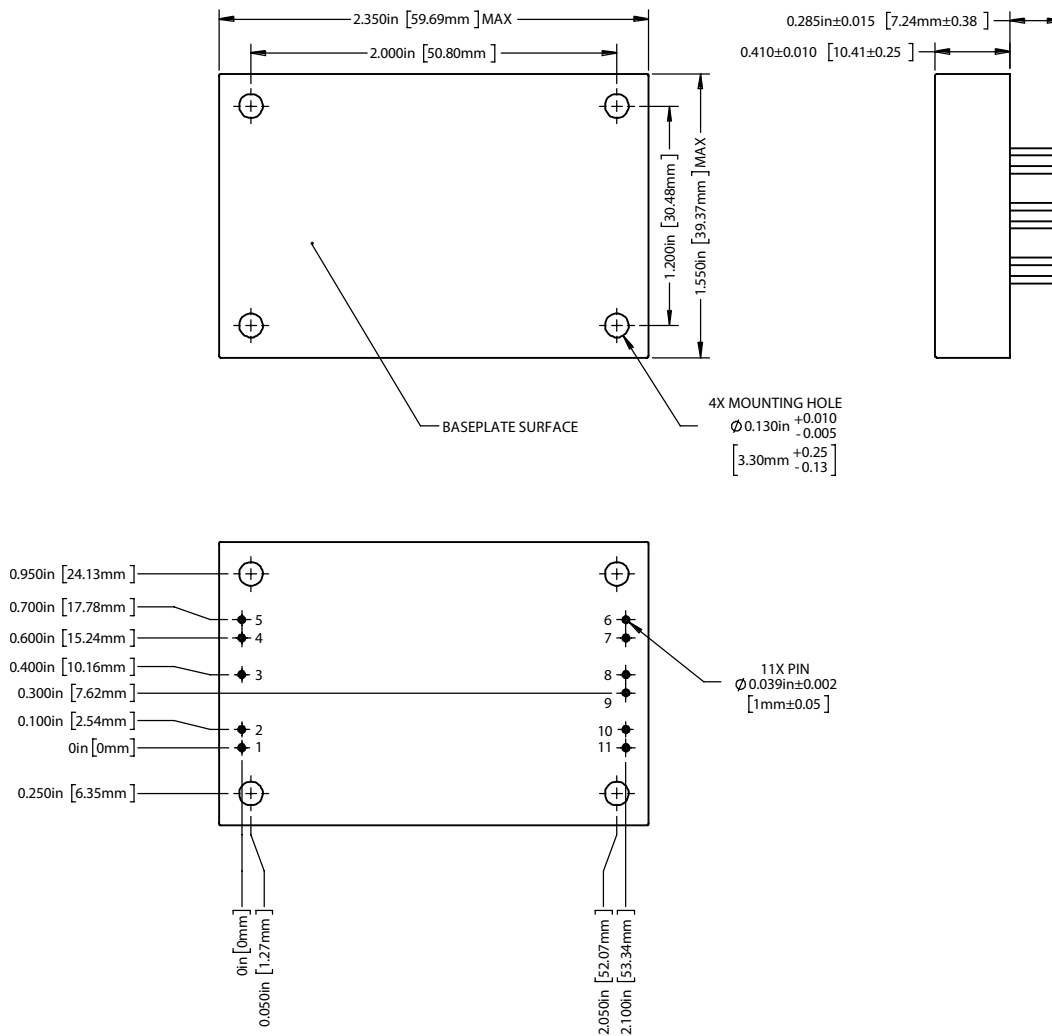

1. Tolerances are ±0.005" unless otherwise stated
2. Case temperature is measured on the center of the baseplate surface
3. Mounting holes are not threaded. Recommended fastener is 4-40
4. Materials: Body (Epoxy with integral metalized EMI shield); Pin (Tellurim Copper, alloy 145, gold over nickel plating)

Pin	Function	Pin	Function	Pin	Function	Pin	Function
1	28VIN	4	INCOM	7	-SENSE	10	+SENSE
2	SYNC	5	INH	8	TRIM	11	+VOUT
3	CASE	6	OUTCOM	9	SHARE		

6.0 TECHNICAL NOTES



Please note that many of these functions are also demonstrated in detail on the VPT website in the form of [technical video labs](#).



6.1 GENERAL INFORMATION

6.1.1 Topology Description

The VXR100-2800S Series is an isolated single-output flyback DC-DC converter. The fixed frequency synchronous rectified flyback topology provides high efficiency over a wide input voltage range. Proprietary secondary-side feedback control provides a tightly regulated positive output voltage with fast transient response while eliminating analog feedback isolation.

6.1.2 External Components

The VXR100-2800S Series is designed to operate stand-alone and does not require external components for proper operation in meeting the datasheet specifications. Input and output L-C filters are provided internally for low ripple and noise. To further reduce output ripple and noise for more sensitive applications, a small ceramic capacitor, 1  $\mu$ F to 10  $\mu$ F, can be added to the output. Most application specific ripple requirements can be met with the addition of output capacitors alone. External output capacitance can be added up to the maximum listed in Section 3.2.

6.1.3 Source Impedance

The impedance of the 28 V input source can interact with the DC-DC converter and may affect performance. High source impedance is often caused by a long input cable or components added in series with the input. Source resistance will cause a DC voltage drop as the converter draws DC input current. This voltage drop is determined by multiplying the cable resistance by the input current at low line. The voltage drop and the actual voltage at the input to the converter will determine the minimum source voltage at which the converter will operate. A high source inductance can interact with the feedback control loop of the converter. VPT's EMI filters will typically isolate the source and eliminate this problem. In some cases, additional input capacitance may be needed to stabilize the system.

6.1.4 Output Configurations

Since the converter is isolated, the output can be configured as a positive or negative voltage. For example, the VXR100-2812S can provide +12 V DC referenced to OUTCOM or -12 V DC referenced to +VOUT.

The outputs of multiple converters can be stacked in series to provide higher voltages. When outputs of multiple modules are stacked, they naturally share the load. For example, two VXR100-2812S converters can be stacked to provide a 24 V DC output at 200 W.

6.2 FUNCTION DESCRIPTIONS

6.2.1 On/Off Control (Inhibit)

The INH (Inhibit) pin is a primary-side control pin referenced to INCOM. The INH pin must be driven using an open collector or open drain configuration. Pulling the INH pin low disables the converter output, removes bias voltage from internal control circuitry, and puts the converter in a state of minimum input current draw. Leaving INH open enables the output, allowing the converter to operate normally. The pin must be pulled below 0.2 V to disable the output. An optional capacitor from INH to INCOM may be used to delay turn-on. The INH pin should be left open if not used.

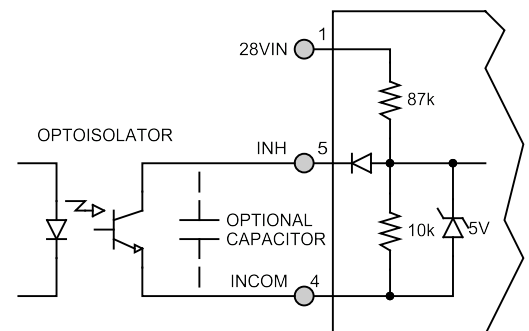





**6.2.2 Adjusting the Output Voltage (TRIM)**

The output voltage set point of the converter can be adjusted using the TRIM pin. To adjust the output up, connect the trim resistor from TRIM to OUTCOM. To adjust the output down, connect the trim resistor from TRIM to +VOUT. The maximum trim range is -20% and +10% from nominal. The appropriate resistor values versus the output voltage are given in the table below. Because the TRIM pin can be sensitive to external noise, the trim resistor should be physically located close to the VXR100 converter with short interconnects. The TRIM pin should be left open if not used. When adjusting the output voltage, do not exceed the rated total output power or output current.

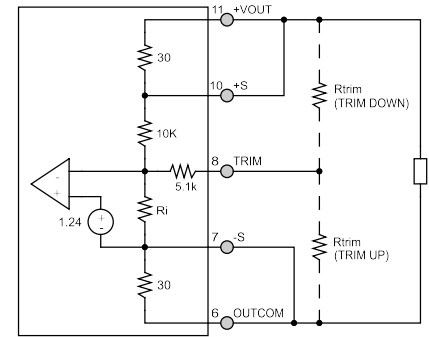

VXR100-283R3S		VXR100-2805S		VXR100-2807S		VXR100-2812S		VXR100-2815S		VXR100-2818S	
+Vout (V)	Rtrim (Ω)	+ Vout (V)	Rtrim (Ω)	+ Vout (V)	Rtrim (Ω)	+ Vout (V)	Rtrim (Ω)	+ Vout (V)	Rtrim (Ω)	+ Vout (V)	Rtrim (Ω)
3.6	36.3k	5.5	19.7k	7.7	12.8k	13.2	5.42k	16.5	3.1k	19.8	1.8k
3.55	44.5k	5.4	25.9k	7.6	15.8k	13	7.58k	16.25	4.8k	19.55	2.9k
3.5	57.0k	5.3	36.2k	7.5	20.1k	12.8	10.8k	16	7.3k	19.3	4.5k
3.45	77.7k	5.2	56.8k	7.4	26.5k	12.6	16.4k	15.75	11.4k	19.05	6.8k
3.4	119k	5.1	119k	7.3	37.3k	12.4	27.7k	15.5	19.6k	18.8	10.5k
3.35	244k	5		7.2	59.3k	12.2	64.8k	15.25	44.0k	18.55	17.6k
3.3		4.9	362k	7.1	128.9k	12		15		18.3	36.9k
3.25	395k	4.8	173k	7		11.8	469k	14.75	540k	18	
3.2	190k	4.7	110k	6.85	351k	11.6	240k	14.5	261k	17.64	445k
3.15	122k	4.6	78.9k	6.7	172k	11.4	158k	14.25	169k	17.28	216k
3.1	87.8k	4.5	60.1k	6.55	111k	11.2	116k	14	123k	16.92	139k
3.05	67.2k	4.4	47.6k	6.4	79.8k	11	90k	13.75	95.2k	16.56	101k
3	53.5k	4.3	38.6k	6.25	61k	10.8	73k	13.5	76.7k	16.2	77.8k
2.95	43.7k	4.2	31.9k	6.1	48.4k	10.6	61k	13.25	63.6k	15.84	62.3k
2.9	36.4k	4.1	26.7k	5.95	39.4k	10.4	51k	13	53.8k	15.48	51.3k
		4	22.5k	5.8	32.7k	10.2	44k	12.75	46.1k	15.12	43.0k
				5.65	27.4k	10	38k	12.5	40.0k	14.76	36.6k
						9.8	33k	12.25	35.0k	14.4	31.4k
						9.6	29k	12	30.8k		

**6.2.3 Remote Sense (+S, -S)**

Remote sensing compensates for voltage drops in the output pins and traces by sensing and regulating directly at the load. The remote sense function can compensate for up to a 10% voltage drop (5% in the positive lead and 5% in the negative lead). The sum of the TRIM up and remote sense compensation cannot exceed 10% such that the voltage at the output terminals of the converter does not exceed 110% of the nominal output voltage. If not used, the user should connect +S to +VOUT and -S to OUTCOM at the pins of the converter.

**6.2.4 Frequency Synchronization (SYNC)**

The VXR100-2800S Series will free run at a switching frequency of approximately 500 kHz, which has been set for optimum converter performance. Frequency synchronization is not necessary unless required by system constraints. The VXR100-2800S Series provides a frequency synchronization input (SYNC) referenced to INCOM.

The SYNC pin can be driven by an external clock. The internal clock and internal power train will operate at the frequency applied to the SYNC pin. The SYNC pin should be driven with a TTL type 5 V square wave signal. The duty cycle of the square wave should be between 40% and 60%. Proper layout and circuit techniques are necessary to prevent noise from being injected into this pin. Synchronized converters should be located physically close together and share a low impedance INCOM connection. The SYNC pin should be connected to INCOM if not used.

### 6.2.5 Parallel Operation (SHARE)

The VXR100-2800S Series provides a SHARE function for active current sharing among paralleled modules. To enable load sharing, connect a single wire between the SHARE pins of all parallel modules. The SHARE pin can be noise sensitive. Paralleled converters should be located physically close to one another and share a low impedance OUTCOM connection. A symmetrical layout of the output traces will improve share accuracy. Frequency synchronization is not required for parallel operation. The SHARE pin should be left open if not used.

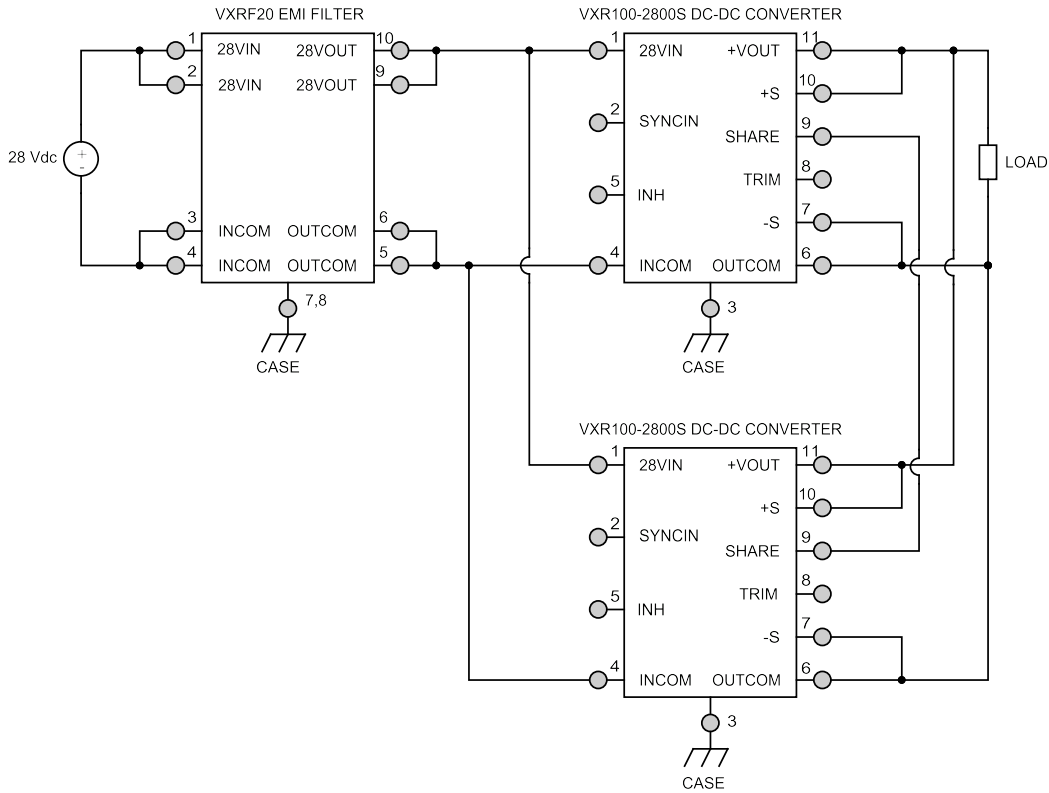

## 6.3 PROTECTION FEATURES

### 6.3.1 Input Undervoltage Lockout

The VXR100-2800S Series provides input undervoltage lockout protection. For input voltages below the turn-on voltage, the converter will remain off, drawing minimal current from the source. When the input voltage exceeds the turn-on voltage, the converter will start. The lockout circuit is designed to accept slow ramping input voltage waveforms. The VXR100-2800S circuit provides bias voltage to all secondary control circuits and control amplifiers before the output starts, ensuring a well-controlled start up sequence.

### 6.3.2 Output Soft Start

The VXR100-2800S Series utilizes an output soft-start function to ramp the output in a controlled manner, eliminating output voltage overshoot and limiting inrush current at turn on. A voltage-mode soft-start ensures the output waveform remains consistent regardless of changes in the load current. The output rise time is approximately 4 ms. The soft-start function is active whether the module is turned on with an application of input voltage or from release of the inhibit pin. Under normal conditions, current drawn from the source during turn-on will not exceed the full-load input current. The turn-on delay time is specified from the application of input voltage (or release of the inhibit pin) until the output reaches 90% of its final value.

### 6.3.3 Output Overcurrent Protection

The VXR100-2800S Series provides output overcurrent and output short circuit protection. During a load fault condition, a constant output current control circuit reduces the converter duty cycle to limit the output current to approximately 130% of its rated value. The converter will continue to provide constant current into any overload or short circuit condition. This feature allows the converter to start into any capacitive load. Recovery is automatic and immediate upon removal of the fault condition. Sustained short circuit or overload operation can cause excessive power dissipation. Care should be taken to control the operating temperature of the converter in this condition.

## 6.4 PACKAGE

### 6.4.1 Package Description

The VXR100-2800S is constructed with an epoxy encapsulated V-SHIELD<sup>®</sup> package that includes integral metallization for enhanced EMI shielding. The ruggedized package is highly resistant to chemical, solvent and salt environments and is fully compatible with high volume manufacturing processes including wave solder, cleaning solvents, high pressure sprays and aqueous wash processes. The encapsulated converter allows for superior shock and vibration performance in a low-weight package.

### 6.4.2 Thermal Performance

The VXR100-2800S Series is rated for full power operation at 105 °C. Operation above 105 °C is allowed at reduced power. Specifically, the output power should be derated linearly from full power at 105 °C to half power at 110 °C and to zero power at 115 °C. The operating temperature of the converter is specified on the baseplate or top plate of the converter. The converter is designed to be conduction-cooled, with either the baseplate or top plate mounted to a heat sink, chassis, PCB or other thermal surface.

The DC-DC converter contains many semiconductor components. The maximum temperature rise from junction to case is 17 °C at full load.



## 7.0 ENVIRONMENTAL SCREENING

Test	Condition
Internal Visual	IPC-A-610, Class 3
Stabilization Bake	MIL-STD-883, Method 1008, Condition B, 125 °C, 24 hours
Temperature Cycling	MIL-STD-883, Method 1010, Condition B, -55 °C to +125 °C, 10 Cycles
Burn In	96 hours at +105 °C
Final Electrical	100% at 25 °C
External Visual	Internal Procedure

## 8.0 ORDERING INFORMATION

<b>VXR100-</b>	<b>28</b>	<b>05</b>	<b>S</b>
1	2	3	4

(1) Product Series	(2) Nominal Input Voltage	(3) Output Voltage	(4) Number of Outputs
<b>VXR100-</b>	<b>28</b> 28 Volts	<b>3R3</b> 3.3 Volts <b>05</b> 05 Volts <b>07</b> 07 Volts <b>12</b> 12 Volts <b>15</b> 15 Volts <b>18</b> 18 Volts	<b>S</b> Single

Please contact your sales representative or the VPT Inc. Sales Department for more information concerning additional environmental screening and testing, different input voltage, output voltage, power requirements, and source inspection.

## 9.0 CONTACT INFORMATION

To request a quotation or place orders please contact your sales representative or the VPT, Inc. Sales Department at:

**Phone:** (425) 353-3010  
**Fax:** (425) 353-4030  
**E-mail:** vptsales@vptpower.com

All information contained in this datasheet is believed to be accurate, however, no responsibility is assumed for possible errors or omissions. The products or specifications contained herein are subject to change without notice. VPT, its logo and tagline are registered trademarks in the U.S. Patent and Trademark Office.

## 10.0 ADDITIONAL INFORMATION

Visit the VPT website for additional technical resources, including:

### Product Catalogs



### Application Notes and White Papers



### Technical Video Labs



### Additional Products For Avionics/Military, Hi-Rel COTS, and Space Applications

