

Tension-Clamp Ultra-Slim Signal Conditioners M6S Series

CT TRANSMITTER

(clamp-on current sensor)

Functions & Features

- Maintenance-free tension clamp connection
- Converts AC current signal into a low-ripple standard process signal suitable to be handled for computer inputs
- 5.9-mm wide ultra-slim design
- Low profile allows the M6S module mounted in a 120-mm deep panel
- High-density mounting
- Power indicator LED

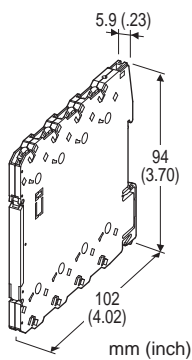

- 240: 0 - 40 A AC
- 250: 0 - 50 A AC
- 260: 0 - 60 A AC
- 275: 0 - 75 A AC
- 2100: 0 - 100 A AC
- 2125: 0 - 125 A AC
- 2150: 0 - 150 A AC
- 2175: 0 - 175 A AC
- 2200: 0 - 200 A AC
- 2225: 0 - 225 A AC
- 2250: 0 - 250 A AC
- 2300: 0 - 300 A AC
- 2350: 0 - 350 A AC
- 2400: 0 - 400 A AC
- 2500: 0 - 500 A AC
- 2600: 0 - 600 A AC

[2] OUTPUT

Current

- A: 4 - 20 mA DC (Load resistance 550 Ω max.)
- D: 0 - 20 mA DC (Load resistance 550 Ω max.)
- G: 0 - 1 mA DC (Load resistance 11 kΩ max.)
- Z: Specify current (See OUTPUT SPECIFICATIONS)

Voltage

- 3: 0 - 1 V DC (Load resistance 1000 Ω min.)
- 4: 0 - 10 V DC (Load resistance 10 kΩ min.)
- 5: 0 - 5 V DC (Load resistance 5000 Ω min.)
- 6: 1 - 5 V DC (Load resistance 5000 Ω min.)
- 4W: -10 - +10 V DC (Load resistance 20 kΩ min.)
- 5W: -5 - +5 V DC (Load resistance 10 kΩ min.)
- 0: Specify voltage (See OUTPUT SPECIFICATIONS)

MODEL: M6SCTC-[1][2]-R[3]

ORDERING INFORMATION

- Code number: M6SCTC-[1][2]-R[3]
 - Specify a code from below for each [1] through [3].
(e.g. M6SCTC-56004W-R/Q)
 - Special output range (For codes Z & 0)
 - Specify the specification for option code /Q
(e.g. /C01)
- Order Clamp-on current sensor separately.

[1] INPUT

Sensor CLSE

- 5R5: 0 - 5 A AC
- 550: 0 - 50 A AC
- 5100: 0 - 100 A AC
- 5200: 0 - 200 A AC
- 5400: 0 - 400 A AC
- 5600: 0 - 600 A AC

Sensor CLSB (CE not available)

- 210: 0 - 10 A AC
- 215: 0 - 15 A AC
- 220: 0 - 20 A AC
- 230: 0 - 30 A AC

POWER INPUT

DC Power

- R: 24 V DC
(Operational voltage range 24 V ±10 %, ripple 10 %p-p max.)

[3] OPTIONS

- blank: none
- /Q: With options (specify the specification)

SPECIFICATIONS OF OPTION: Q

COATING (For the detail, refer to M-System's web site.)

- /C01: Silicone coating
- /C02: Polyurethane coating

RELATED PRODUCTS

- Clamp-on current sensor (model: CLSB)
 - Clamp-on current sensor (model: CLSE)
- (Select "CLSE-x/CE" to comply with CE for the combination)

with the sensor.)

GENERAL SPECIFICATIONS

Connection

Input and output: Tension clamp

Power input: Via the Installation Base (model: M6SBS)
or Tension clamp

Applicable wire size: 0.2 to 2.5 mm², stripped length 8 mm

Housing material: Flame-resistant resin (black)

Isolation: Input to output to power

Input waveform

RMS sensing: Up to 15 % of 3rd harmonic content

Zero adjustment: -2 to +2 % (front)

(Output code 4W, 5W: Adjustable at 0V. No output below 0 mA for the code D.)

Span adjustment: 98 to 102 % (front)

Power LED: Green light turns on when the power is supplied.

INPUT SPECIFICATIONS

■ Clamp-on current sensor CLSE

(Sensor model No.: AC input)

CLSE-R5: 0 - 5 A

CLSE-05: 0 - 50 A

CLSE-10: 0 - 100 A

CLSE-20: 0 - 200 A

CLSE-40: 0 - 400 A

CLSE-60: 0 - 600 A

Frequency: 50 / 60 Hz

Operational range: 5 - 120 % of rating

Overload capacity:

CLSE-R5: 10 A continuous

CLSE-05: 60 A continuous

CLSE-10: 120 A continuous

CLSE-20: 240 A continuous

CLSE-40: 480 A continuous

CLSE-60: 720 A continuous

Be sure that the input voltage is of 480 V or less.

■ Clamp-on current sensor CLSB

(Sensor model No.: AC input)

CLSB-05:

0 - 10 A, 0 - 15 A, 0 - 20 A

0 - 30 A, 0 - 40 A, 0 - 50 A

CLSB-10:

0 - 60 A, 0 - 75 A, 0 - 100 A

CLSB-20:

0 - 125 A, 0 - 150 A, 0 - 175 A

0 - 200 A, 0 - 225 A, 0 - 250 A

CLSB-40:

0 - 300 A, 0 - 350 A, 0 - 400 A

CLSB-60:

0 - 500 A, 0 - 600 A

Frequency: 50 / 60 Hz

Operational range: 5 - 120 % of rating

Overload capacity:

CLSB-05: 100 A continuous

CLSB-10: 200 A continuous

CLSB-20: 300 A continuous

CLSB-40: 600 A continuous

CLSB-60: 720 A continuous

Be sure that the input voltage is of 440 V or less.

OUTPUT SPECIFICATIONS

■ **DC Current:** 0 - 20 mA DC

Minimum span: 1 mA

Offset: Max. 1.5 times span

Load resistance: Output drive 11 V max.

■ **DC Voltage:** 0 - 10 V DC

Minimum span: 1 V

Offset: Max. 1.5 times span

Load resistance: Output drive 1 mA max.; at ≥ 1 V

INSTALLATION

Power consumption: Approx. 0.5 W

Operating temperature: -20 to +55°C (-4 to +131°F)

Operating humidity: 30 to 90 %RH (non-condensing)

Mounting: Installation Base (model: M6SBS) or DIN rail

Weight: 60 g (2.1 oz)

PERFORMANCE in percentage of span

Accuracy: ± 0.5 % with input 5 - 100 %

Temp. coefficient: ± 0.015 %/°C (± 0.008 %/°F)

Response time: ≤ 1 sec. (0 - 90 %)

Line voltage effect: ± 0.1 % over voltage range

Insulation resistance: ≥ 100 M Ω with 500 V DC

Dielectric strength: 2000 V AC @1 minute (input to output to power to ground)

STANDARDS & APPROVALS

EU conformity:

EMC Directive

EMI EN 61000-6-4

EMS EN 61000-6-2

RoHS Directive

EN 50581

EXTERNAL VIEW

(With the cover open)

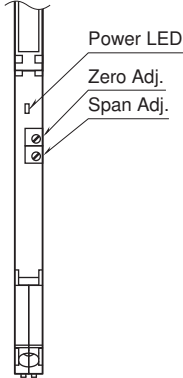

EXTERNAL DIMENSIONS & TERMINAL ASSIGNMENTS unit: mm (inch)

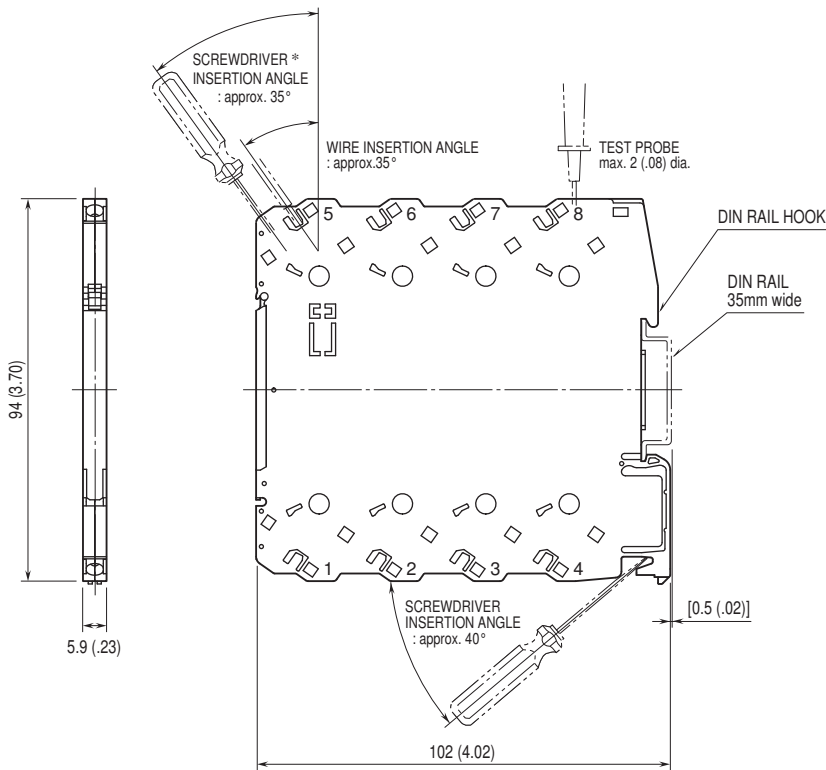

• When mounting, no extra space is needed between units.
 *Use a minus screwdriver: tip width 3.8 mm max., tip thickness 0.5 to 0.6 mm

SCHEMATIC CIRCUITRY & CONNECTION DIAGRAM

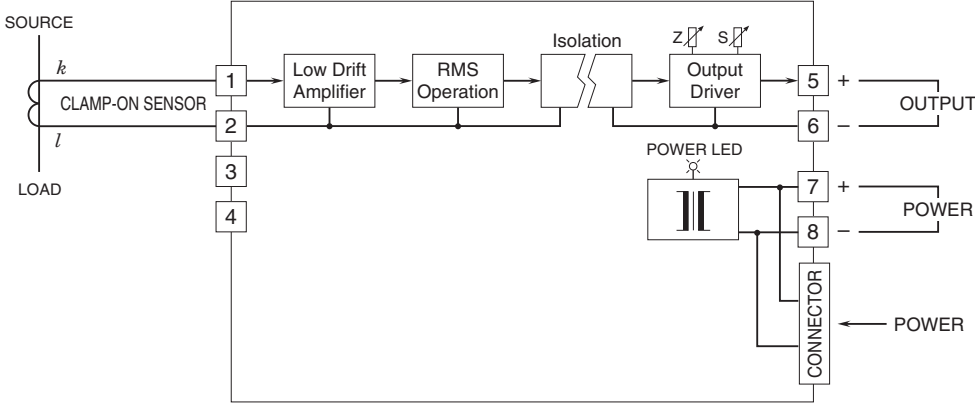

Specifications are subject to change without notice.