

Book-style EMC/RFI Filter for regenerative drive application

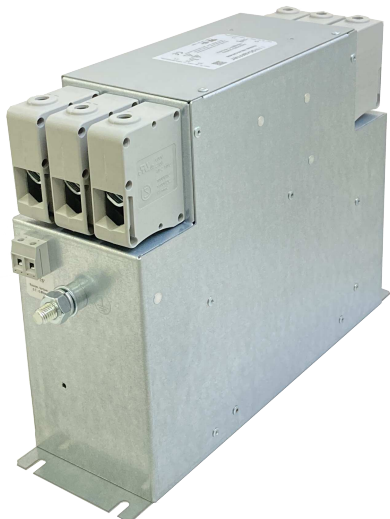

- Designed for usage together with LCL filter
- Easy design in with system approach documentation
- Footprint space-saving book-style housing
- Thermal shutdown capability
- Solid safety connector blocks
- Versions with low leakage current



Performance indicators

Attenuation performance

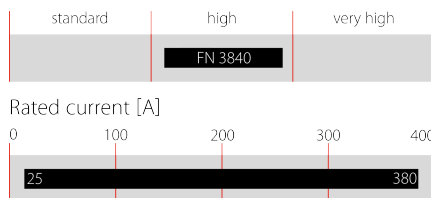

Approvals & Compliances



Features and benefits

- FN 3840 series of filters provides state-of-the-art EMI attenuation based on an innovative filter topology. They help to ensure compliance with Class C2 or even C1 limits.
- The filters are built to fit perfectly to regenerative drive applications with LCL filters
- Internal thermocouples ensure reliability and thermal shutdown capabilities
- The slim book-style shape allows a convenient and space-saving installation next to inverters, converters or motor drives.
- The filters offer very high saturation performance, bundled with best EMI performance
- Fulfills the requirements in IEC/EN 61800-5-1 for electric strength, clearance and creepage
- Fulfills the requirements in IEC/EN 60204-1 for insulation resistance, electric strength, clearance and creepage
- Fulfills the requirements in IEC/EN 62477-1 for electric strength, clearance and creepage

Technical specifications

Maximum continuous operating voltage	3x 530/305 VAC
Operating frequency	DC to 60 Hz
Rated currents	25 to 380 A @50°C
Overload capability	6x rated current for 1 sec, once per hour 1.6x rated current for 1 minute, once per hour
Climatic class	40/100/21 acc. to IEC 60068-1
Temperature range (operation and storage)	-40°C to +100°C (with current derating >50°C)
High potential test voltage	P -> E 2550 VDC for 2 s P -> P 2550 VDC for 2 s TS/TS' -> E 2550 VDC for 2 s TS/TS' -> P 2550 VDC for 2 s
Pollution degree	2 acc. IEC 60664-1
Overvoltage category	III acc. IEC 60664-1
Surge withstand	2kV (P-P) / 4kV (P - E) acc. to IEC 6100-4-5
Altitude	up to 2000m no derating applies. Above 2000m derating acc. to IEC 60664-1 applies
Design corresponding to	UL 60939-3, IEC 60939-3
Compliance with insulation requirement	> 1 MOhm acc. to IEC 60204-1
Protection category	IP 20 (terminal block versions) and IP00 (busbar versions) acc. to IEC 60529-1
Vibration and shock	3M4 (operation) acc. to IEC 60721-3-3
Flammability corresponding to	Terminals: UL 94 V-0
MTBF	> 300,000 hours

Typical applications

- Regenerative drives in combination with LCL filters
- Active infeed converter (AIC)
- Active front end (AFE) variable frequency drives (VFD)
- Three-phase variable speed drives (VSD) and power drive systems (PDS)
- Renewable Energy
- Machine tool and machinery equipment
- Process automation equipment

Typical electrical schematic (please refer to page 2 for further details)

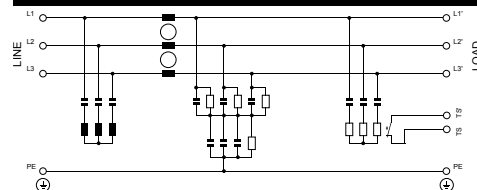

Filter selection table

Filter	Rated current	Typical drive	Leakage current**	DC Resistance	Typical Power Dissipation	Terminal Type	Weight	Thermal Switch***
	@ 50°C [A]	power rating* [kW]	@ 530 VAC/50 Hz [mA]	@ 25°C [mOhm]	[W]	Switching Temp. [°C]		
FN3840-25-33-C35-R65	25	15	4.3	9.5	22	-33	2.5	180
FN3840-50-53-C35-R65	50	30	4.3	5	43	-53	3.5	180
FN3840-80-34-C45-R65	80	45	7.7	1.5	40	-34	5.7	180
FN3840-160-40-C45-R65	160	90	7.7	0.4	40	-40	7.9	180
FN3840-250-99-C2835-R67	250	150	10.7	0.1	26	-99	4.3	150
FN3840-380-99-C2835-R67	380	200	10.7	0.07	33	-99	4.5	150

* Typical power rating at 400 VAC with cos phi=0.85. The exact value depends upon the efficiency of the drive, the motor and the entire application.

** Standardized calculated leakage current acc. IEC 60939 under normal operating conditions.

*** Normally closed thermal protector switch, 250VAC / 24VDC, 6.3A (with cos phi 0.6); reverse switching temperature = switching temp - 50K.

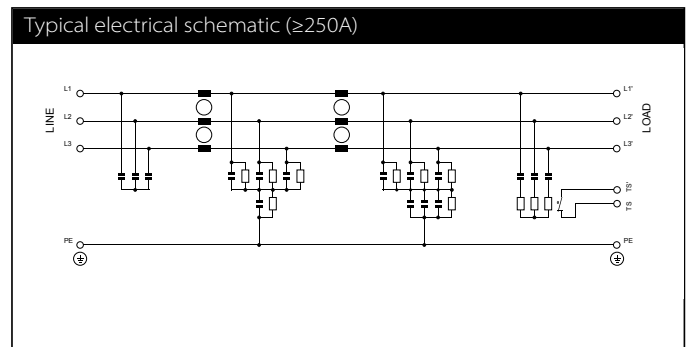
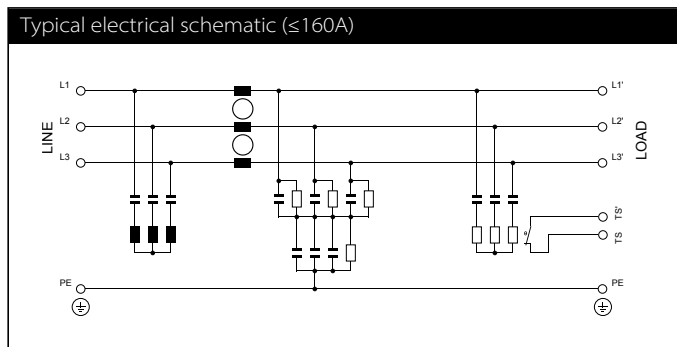

Tolerances apply: L +50%/-30% , C ±20%, R ±10%

Typical filter attenuation

Per CISPR 17: symmetrical 50 Ω/50 Ω -> Differential Mode (DM); asymmetrical 50 Ω/50 Ω -> Common Mode (CM)

FN3840-25-33-C35-R65

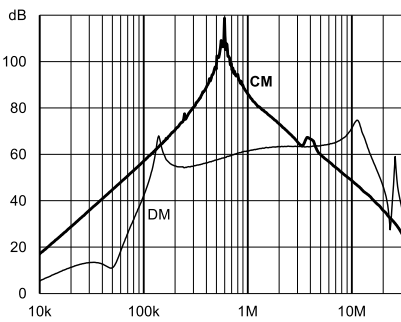

FN3840-50-53-C35-R65

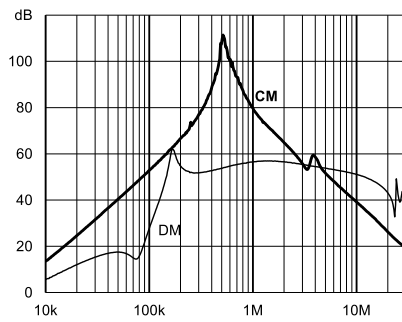

FN3840-80-34-C45-R65

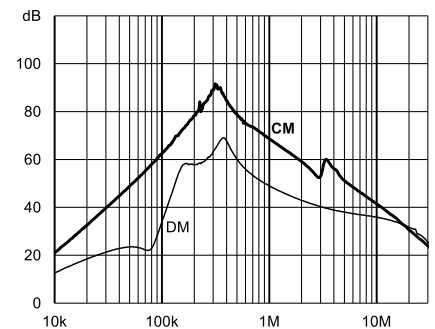

FN3840-160-40-C45-R65

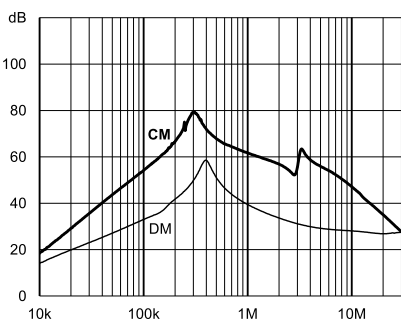

FN3840-250-99-C2835-R67

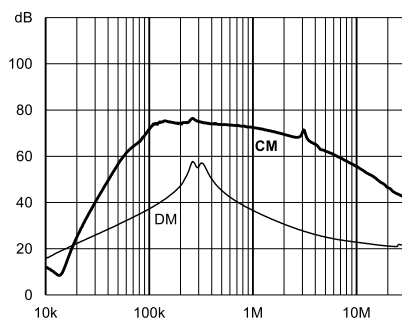

FN3840-380-99-C2835-R67

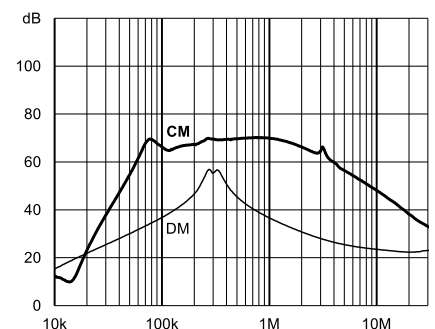

Typical application

System diagram of an Active Front End (AFE) application

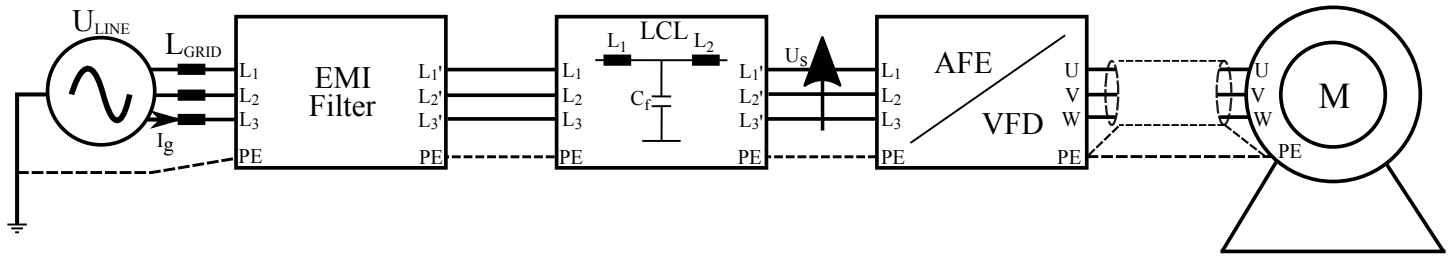

Frequency response

Frequency response at different values of the grid inductance. The grid inductance is calculated with details mentioned at each graph. Each figure represents the normalized admittance transfer function between the grid current, i_g , and the converter voltage u_s . At low frequencies, the equivalent admittance is inversely proportional to the total DC resistance of the grid, and EMI and LCL filters (R_GRID+R_EMI+R_LCL), which is dominated mainly by the LCL filter R_LCL.

FN3840-25-33-C35-R65

400 VAC/50 Hz, 250 kVA trafo with uk of (1) 1%, (2) 2%, (3) 3%, (4) 4%, (5) 5% and 50m cable.

FN3840-50-53-C35-R65

400 VAC/50 Hz, 250 kVA trafo with uk of (1) 1%, (2) 2%, (3) 3%, (4) 4%, (5) 5% and 50m cable.

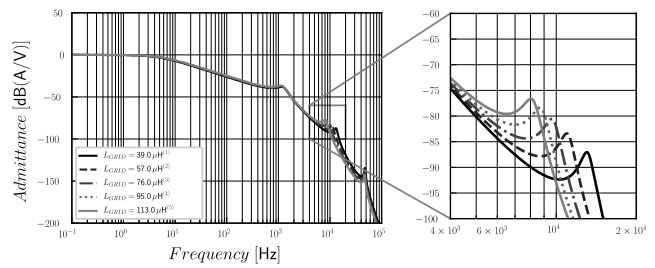
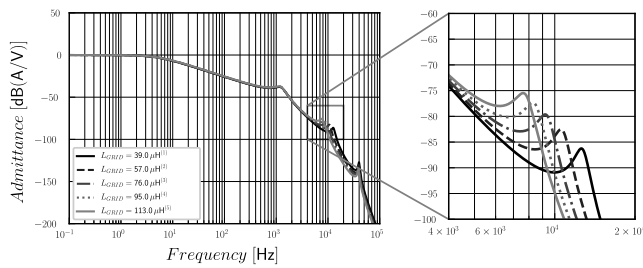

FN3840-80-34-C45-R65

400 VAC/50 Hz, 250 kVA trafo with uk of (1) 1%, (2) 2%, (3) 3%, (4) 4%, (5) 5% and 50m cable.

FN3840-160-40-C45-R65

400 VAC/50 Hz, 315 kVA trafo with uk of (1) 1%, (2) 2%, (3) 3%, (4) 4%, (5) 5% and 50m cable.

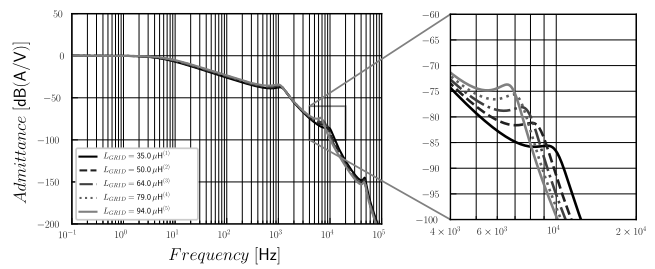
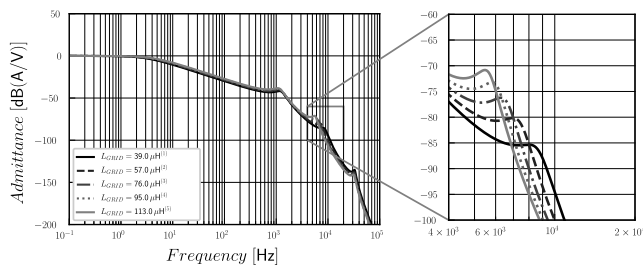

FN3840-250-99-C2835-R67

400 VAC/50 Hz, 500 kVA trafo with uk of (1) 1%, (2) 2%, (3) 3%, (4) 4%, (5) 5% and 50m cable.

FN3840-380-99-C2835-R67

400 VAC/50 Hz, 630 kVA trafo with uk of (1) 1%, (2) 2%, (3) 3%, (4) 4%, (5) 5% and 50m cable.

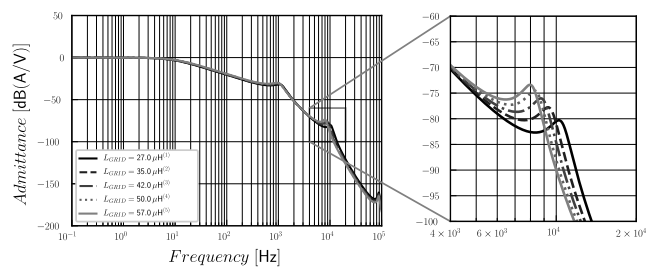
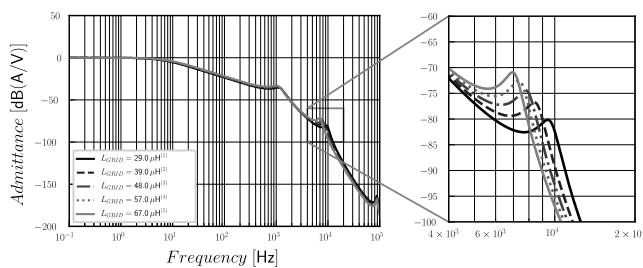

Damping resistor losses vs switching frequency

Typical losses at different values of the AFE-LCL L1 inductor with rated voltage (530 VAC/60 Hz) and differing grid inductance. (25A->95µH; 50A->95µH; 80A-> 95µH; 160A->79µH; 250A->57µH; 380A->50µH).

The highlighted gray area represents a non-operating area. Operating the filter in this area may cause overheating and damage to the filter, and may activate the temperature switch.

FN3840-25-33-C35-R65

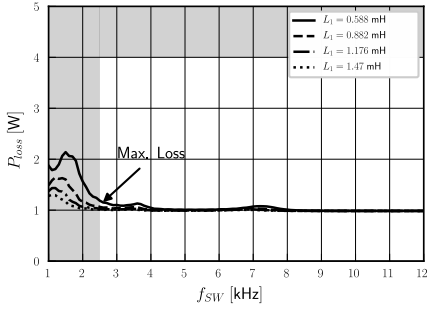

FN3840-50-53-C35-R65

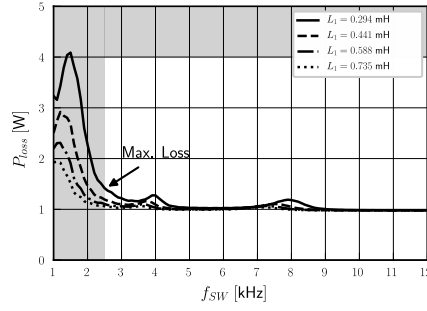

FN3840-80-34-C45-R65

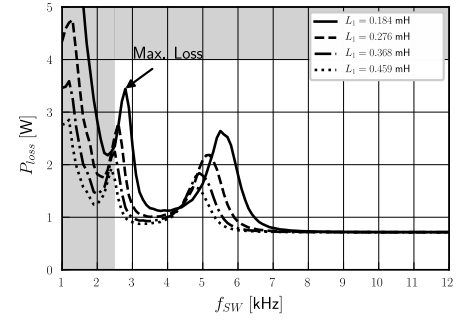

FN3840-160-40-C45-R65

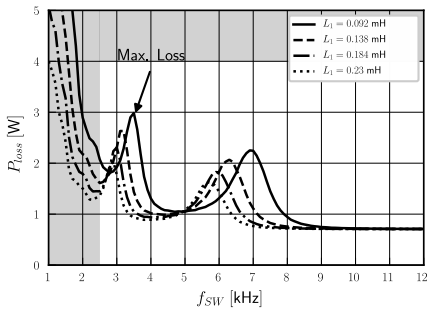

FN3840-250-99-C2835-R67

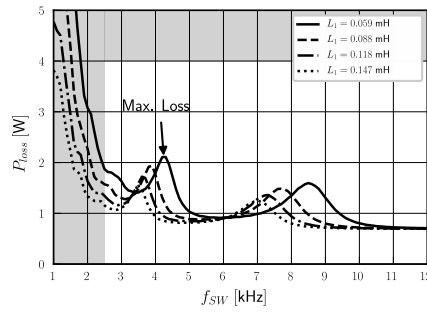

FN3840-380-99-C2835-R67

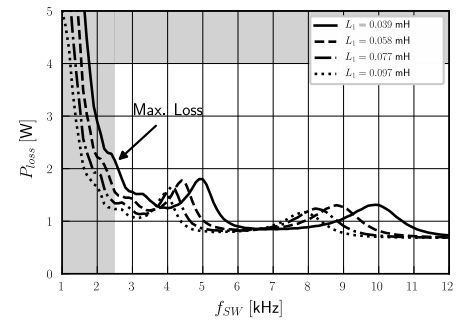

Mechanical data for filters with terminal blocks

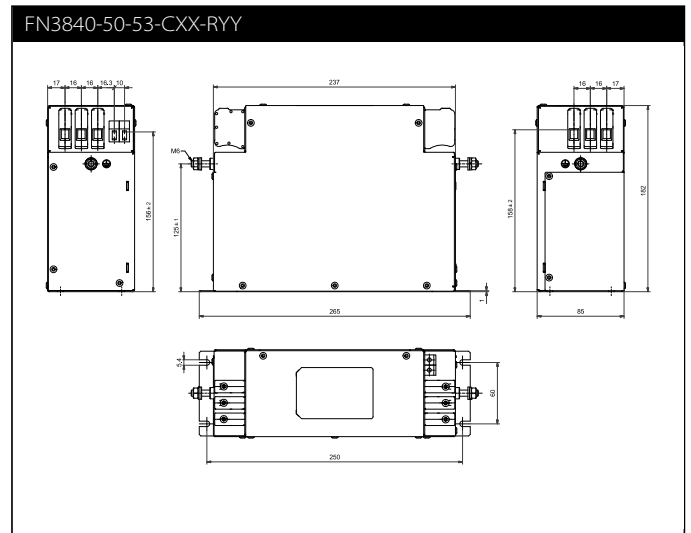
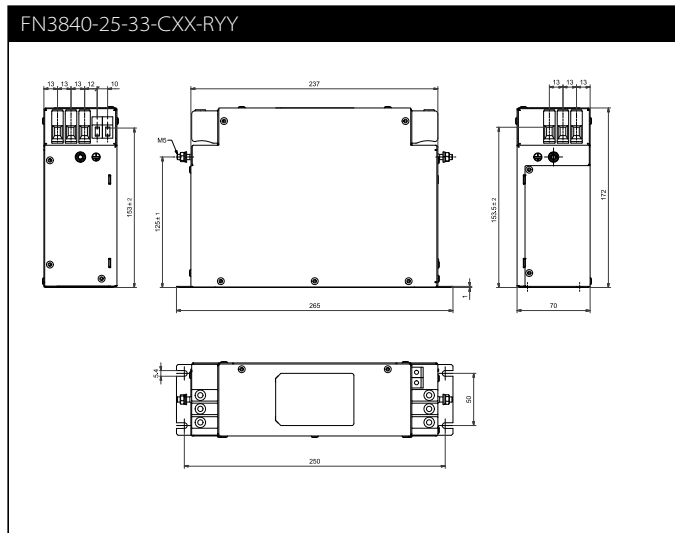

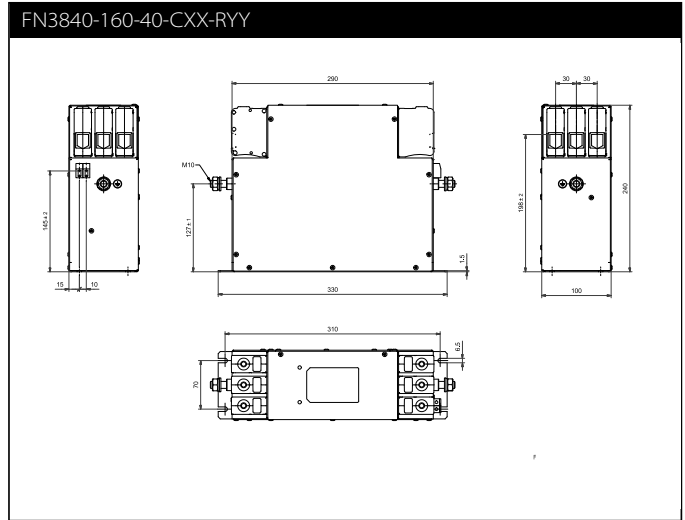
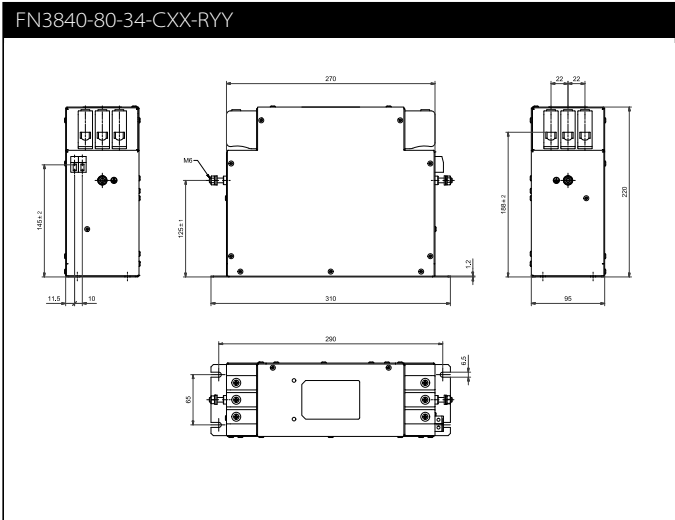

Filter input/output connector cross sections

	-33	-53	-34	-40
Solid wire	0.5-16 mm ²	0.5-16 mm ²	6-35 mm ²	25-95 mm ²
Flex wire	0.5-10 mm ²	0.5-16 mm ²	6-25 mm ²	25-95 mm ²
Flex wire AWG	AWG 22-6	AWG 20-4	AWG 6-2	AWG 0-4/0
Recommended torque	1.5-1.8 Nm	2.0-2.3 Nm	4.0-4.5 Nm	17-20 Nm

Please visit www.schaffner.com to find more details on filter connectors.

Mechanical data for filters with busbar connection

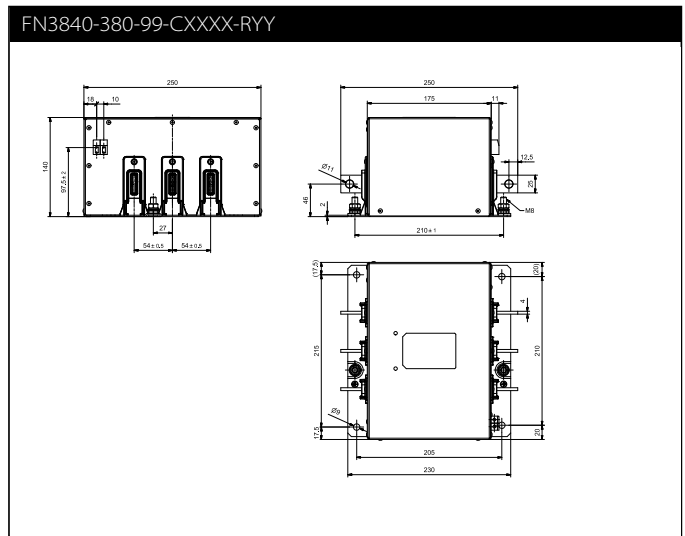
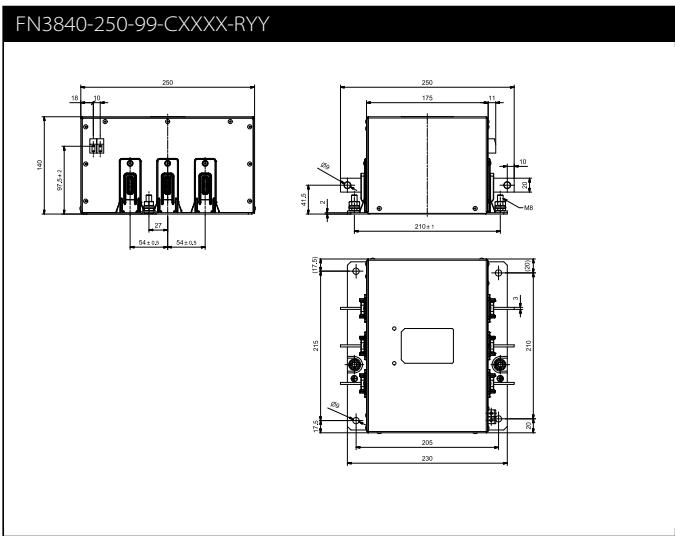



Headquarters, global innovation and development

Switzerland

Schaffner Group

Industrie Nord
Nordstrasse 11e
4542 Luterbach
T +41 32 681 66 26
info@schaffner.com



Sales and application centers

China

Schaffner EMC Ltd. Shanghai

T20-3 C, No 565 Chuangye Road,
Pudong district
201201 Shanghai
T +86 21 3813 9500
cschina@schaffner.com
www.schaffner.com.cn

Finland

Schaffner Oy

Sauvonrinne 19 H
08500 Lohja
T +358 10 567 2855
finlandsales@schaffner.com

France

Schaffner EMC S.A.S.

16-20 Rue Louis Rameau
95875 Bezons
T +33 1 34 34 30 60
F +33 1 39 47 02 28
francesales@schaffner.com

Germany

Schaffner Deutschland GmbH

Schoemperlenstrasse 12B
76185 Karlsruhe
T +49 721 56910
F +49 721 569110
germanysales@schaffner.com

India

Schaffner India Pvt. Ltd

REGUS WORLD TRADE CENTRE
WTC, 22nd Floor Unit No 2238, Brigade
Gateway Campus, 26/1, Dr. Rajkumar Road
Malleshwaram (W)
560055 Bangalore
T +91 80 67935355
indiasales@schaffner.com

Italy

Schaffner EMC S.r.l.

Via Ticino, 30
20900 Monza (MB)
T +39 039 21 41 070
italysales@schaffner.com

Japan

Schaffner EMC K.K.

Taiju-Seimei Sangenjaya Bldg.
1-32-12, Kamiyama, Setagaya-ku
154-0011 Tokyo
T +81 3 5712 3650
F +81 3 5712 3651
japansales@schaffner.com
www.schaffner.jp

Singapore

Schaffner EMC Pte Ltd.

#05-09, Kg Ubi Ind. Estate
408705 Singapore
T +65 6377 3283
F +65 6377 3281
singaporesales@schaffner.com

Spain

Schaffner EMC España

Calle Caléndula 93, Miniparc III, Edificio E
El Soto de Moraleja, Alcobendas
28109 Madrid
T +34 917 912 900
F +34 917 912 901
spainsales@schaffner.com

Sweden

Schaffner EMC AB

Östermalmstorg 1
114 42 Stockholm
T +46 8 5050 2425
swedensales@schaffner.com
www.schaffner.com

Switzerland

Schaffner EMV AG

Industrie Nord
Nordstrasse 11e
4542 Luterbach
T +41 32 681 66 88
T +41 32 681 66 26
switzerlandsales@schaffner.com

Taiwan R.O.C.

Schaffner EMV Ltd.

20 Floor-2, No 97, Section 1, XinTai 5th Road
22175 XiZhi District New Taipei City 22175
T +886 2 2697 5500
F +886 2 2697 5533
taiwansales@schaffner.com
www.schaffner.com.tw

Thailand

Schaffner EMC Co. Ltd.

Northern Region Industrial Estate
67 Moo 4 Tambon Ban Klang
Amphur Muangng P.O. Box 14
51000 Lamphun
T +66 53 58 11 04
F +66 53 58 10 19
thailandsales@schaffner.com

United Kingdom

Schaffner Ltd.

1, Oakmede Place
Binfield
RG42 4JF Berkshire
T +44 118 9770070
F +44 118 9792969
uksales@schaffner.com

USA

Schaffner EMC Inc.

52 Mayfield Avenue
Edison, New Jersey
T +1 732 225 9533
F +1 732 225 4789
usasales@schaffner.com
www.schaffnerusa.com

To find your local partner within Schaffner's global network: www.schaffner.com

© 2020 Schaffner Group

The content of this document has been carefully checked and understood. However, neither Schaffner nor its subsidiaries assume any liability whatsoever for any errors or inaccuracies of this document and the consequences thereof. Published specifications are subject to change without notice. Product suitability for any area of application must ultimately be determined by the customer. In all cases, products must never be operated outside their published specifications. Schaffner does not guarantee the availability of all published products. This disclaimer shall be governed by substantive Swiss law and resulting disputes shall be settled by the courts at the place of business of Schaffner Holding AG. Latest publications and a complete disclaimer can be downloaded from the Schaffner website. All trademarks recognized.