

Space-saving Dual Output Signal Conditioners Mini-MW Series

RTD TRANSMITTER

(PC programmable)

Functions & Features

- Accepts direct input from a RTD
- 4-wire connection available
- Two independent output ranges
- Linearization and burnout
- PC programmable
- High-density mounting

Typical Applications

- Long distance transmission between the RTD and the transmitter
- Combination with intrinsic safety barriers

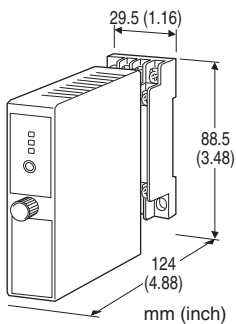

MODEL: W2XR-[1][2][3]-[4][5]

ORDERING INFORMATION

- Code number: W2XR-[1][2][3]-[4][5]

Specify a code from below for each [1] through [5].

(e.g. W2XR-4Z1V3-M2/N/Q)

- Temperature range (e.g. 0 - 100°C)
- Output 1 range (e.g. 4 - 20 mA DC)
- Output 2 range (e.g. 1 - 5 V DC)
- Specify the specification for option code /Q

(e.g. /C01/S01/SET)

Note: If one of the outputs should be a current range, specify it for the Output 1 to allow a greater load.

[1] INPUT RTD

1: JPt 100 (JIS'89)

(Usable range: -200 to +500°C, -328 to +932°F; min.span: 20°C, 36°F)

3: Pt 100 (JIS'89)

(Usable range: -200 to +650°C, -328 to +1202°F; min.span: 20°C, 36°F)

4: Pt 100 (JIS'97, IEC)

(Usable range: -200 to +850°C, -328 to +1562°F; min.span: 20°C, 36°F)

5: Pt 50 Ω (JIS'81)

(Usable range: -200 to +649°C, -328 to +1200°F; min.span: 20°C, 36°F)

7: Pt 1000

(Usable range: -200 to +850°C, -328 to +1562°F; min.span: 20°C, 36°F)

9: Cu 10 @25°C

(Usable range: -50 to +250°C, -58 to +482°F; min.span: 20°C, 36°F)

0: Specify (Please provide a resistance table.)

(Configurator software is used to change the input type and precise range.)

[2] OUTPUT 1

Current

Z1: Range 0 - 20 mA DC

Voltage

V2: Range -10 - +10 V DC

V3: Range -5 - +5 V DC

(Configurator software is used to change output over the described range of the selected suffix code.

For changing between suffix codes, set the Output Range Selector on the side of unit before software adjustment.)

[3] OUTPUT 2

Same range availability as Output 1

Y: None

(Configurator software is used to change output over the described range of the selected suffix code.

For changing between suffix codes, set the Output Range Selector on the side of unit before software adjustment.)

[4] POWER INPUT

AC Power

M2: 100 - 240 V AC (Operational voltage range 85 - 264 V, 47 - 66 Hz)

DC Power

R: 24 V DC

(Operational voltage range 24 V ±10 %, ripple 10 %p-p max.)

R2: 11 - 27 V DC

(Operational voltage range 11 - 27 V, ripple 10 %p-p max.)

P: 110 V DC

(Operational voltage range 85 - 150 V, ripple 10 %p-p max.)

[5] OPTIONS (multiple selections)

Standards & Approvals (must be specified)

/N: Without CE

Other Options

blank: none

/Q: Option other than the above (specify the specification)

SPECIFICATIONS OF OPTION: Q (multiple selections)**COATING (For the detail, refer to M-System's web site.)**

/C01: Silicone coating

/C02: Polyurethane coating

/C03: Rubber coating

TERMINAL SCREW MATERIAL

/S01: Stainless steel

EX-FACTORY SETTING/SET: Preset according to the Ordering Information Sheet
(No. ESU-5503)**RELATED PRODUCTS**

- PC configurator software (model: W2CFG)

Downloadable at M-System's web site.

A dedicated cable is required to connect the module to the PC. Please refer to the internet software download site or the users manual for the PC configurator for applicable cable types.

GENERAL SPECIFICATIONS**Construction:** Plug-in**Connection:** M3 screw terminals (torque 0.8 N·m)**Screw terminal:** Chromated steel (standard) or stainless steel**Housing material:** Flame-resistant resin (black)**Isolation:** Input to output 1 to output 2 to power**Overrange output:** -15 to +115 %

(Negative current output is not available.)

Zero adjustment: -5 to +5 % (PC programming)**Span adjustment:** 95 to 105 % (PC programming)**Burnout:** Upscale standard; downscale, specific value output or no burnout optional by programming**Linearization:** Standard**Status indicator LED:** Tri-color (green/amber/red) LED;

Blinking patterns indicate operation status of the transmitter.

Programming: Downloaded from PC; input type, number of wires and range, output type and range, zero and span, burnout type, user's linearization table, etc.**Configurator connection:** 2.5 dia. miniature jack;
RS-232-C level**INPUT SPECIFICATIONS**

- RTD: 2-, 3- or 4-wire RTDs

Maximum leadwire resistance: 20 Ω per wire**Sensing current:** ≤0.2 mA**Min. span:** 20°C or 36°F

If not specified, the input range is 0 - 100 °C

OUTPUT SPECIFICATIONS

■ DC Current

Maximum range: 0 - 20 mA DC**Conformance range:** 0 - 23 mA DC**Minimum span:** 1 mA**Offset:** Lower range can be any specific value within the output range provided that the minimum span is maintained.**Load resistance:** Output drive 12 V max. for Output 1; 7 V max. for Output 2

(e.g. 4 - 20 mA: 600 Ω [12 V ÷ 20 mA])

If not specified, the output range is 4 - 20 mA DC.

■ DC Voltage

Code V2 (wide spans)**Output range:** -10 - +10 V DC**Conformance range:** -11.5 - +11.5 V DC**Minimum span:** 1 V**Code V3 (narrow spans)****Output range:** -5 - +5 V DC**Conformance range:** -6 - +6 V DC**Minimum span:** 0.5 V**Offset:** Lower range can be any specific value within the output range provided that the minimum span is maintained.**Load resistance:** Output drive 1 mA max.

(e.g. 1 - 5 V: 5000 Ω [5 V ÷ 1 mA])

If not specified, the output range is shown below.

V2: 0 - 10 V DC

V3: 1 - 5 V DC

INSTALLATION**Power Consumption**

• AC:

Approx. 5 VA at 100 V

Approx. 6 VA at 200 V

Approx. 7 VA at 240 V

• DC: Approx. 3 W

Operating temperature: -5 to +55°C (23 to 131°F)**Operating humidity:** 30 to 90 %RH (non-condensing)**Mounting:** Surface or DIN rail**Weight:** 200 g (0.44 lb)**PERFORMANCE in percentage of span****Accuracy:** Input accuracy + output accuracy**Input accuracy*:** (whichever is greater)

±0.1 % of input range or ±0.15°C (Pt and JPt)

±2°C (Cu 10)

Output accuracy*: ≤ ±0.04 % of max. output range

*Inversely proportional to the span.

See CALCULATION EXAMPLES OF OVERALL ACCURACY.

Temp. coefficient: ±0.015 %/°C (±0.008 %/°F) of max. span

Response time: ≤ 1 sec. (0 - 90 %)

(filter time constant: 0)

Burnout response time: ≤ 2 sec.

Line voltage effect: ±0.1 % over voltage range

Insulation resistance: ≥ 100 MΩ with 500 V DC

Dielectric strength: 2000 V AC @1 minute (input to output
1 to output 2 to power to ground)

CALCULATION EXAMPLES OF OVERALL ACCURACY

[Example] Pt 100, 0 - 100°C, Output Type -5 - +5 V, Output Range 1 - 5 V

Input Accuracy*² (0.15°C*³) ÷ Span (100°C) × 100 % + Max.

Output Range (10 V) ÷ Span (4 V) × 0.04 % = 0.25 %

*2, Calculate the accuracy in °C.

*3, 100°C × 0.1 % = 0.1°C ≤ 0.15°C. 0.15°C is used as input accuracy value.

EXTERNAL VIEW

FRONT VIEW

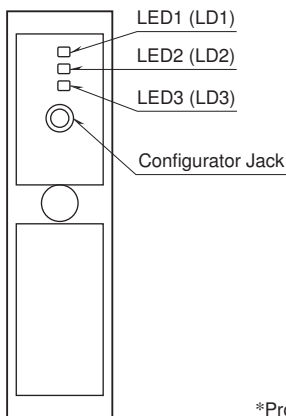

SIDE VIEW

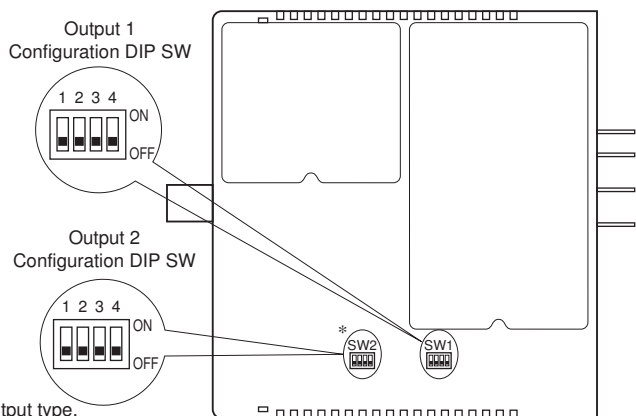

Refer to the instruction manual for detailed procedures.

EXTERNAL DIMENSIONS & TERMINAL ASSIGNMENTS unit: mm (inch)

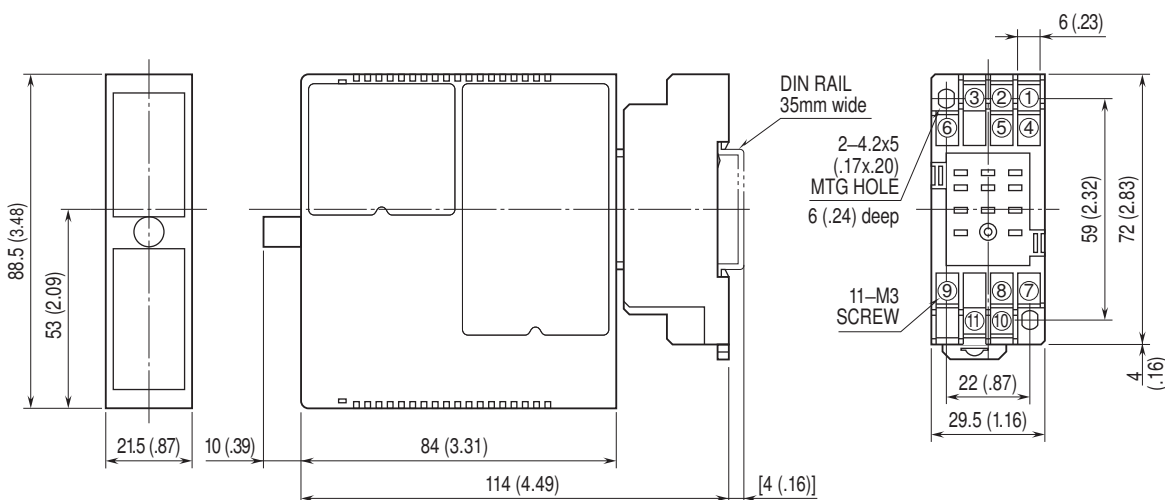

• When mounting, no extra space is needed between units.

SCHEMATIC CIRCUITRY & CONNECTION DIAGRAM

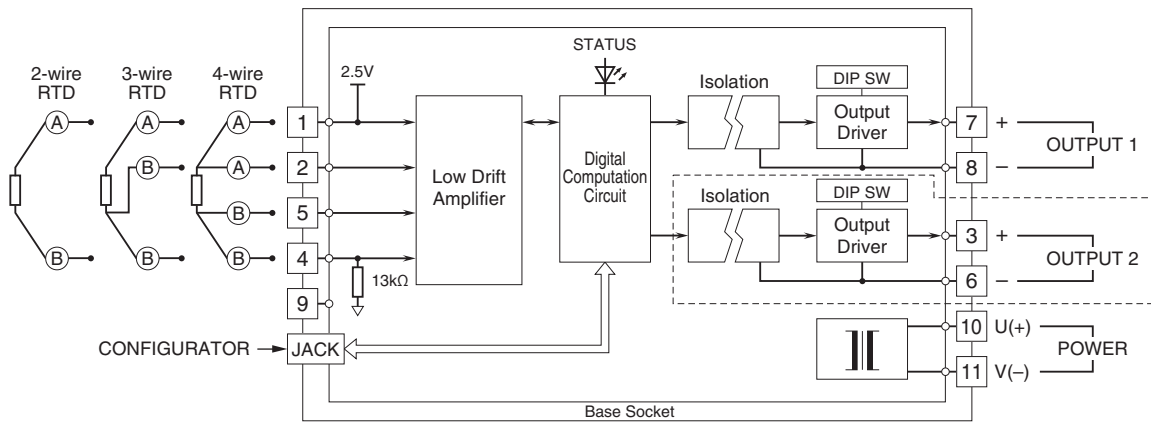

Specifications are subject to change without notice.