

## Multi-band RF frequency synthesizer with integrated VCOs

Preliminary Data

### Feature summary

- Integer-N Frequency Synthesizer
- Dual differential integrated VCOs with automatic center frequency calibration:
  - 3300 - 3900 MHz (Direct output)
  - 3800 - 4400 MHz (Direct output)
  - 1650 - 1950 MHz (Internal divider by 2)
  - 1900 - 2200 MHz (Internal divider by 2)
  - 825 - 975 MHz (Internal divider by 4)
  - 950 - 1100 MHz (Internal divider by 4)
- Excellent integrated phase noise
- Fast lock time: 150µs
- Dual modulus programmable prescaler (16/17 or 19/20)
- 2 programmable counters to achieve a feedback division ratio from 256 to 65551 (prescaler 16/17) and from 361 to 77836 (prescaler 19/20).
- Programmable reference frequency divider (10 bits)
- Phase frequency comparator and charge pump
- Programmable charge pump current
- Digital Lock Detector
- Dual Digital Bus Interface: SPI and I<sup>2</sup>C bus with 3 bit programmable address (1100A<sub>2</sub>A<sub>1</sub>A<sub>0</sub>)
- 3.3V Power Supply
- Power down mode (HW and SW)
- Small size exposed pad VFQFPN28 package 5x5x1.0mm
- Process: BICMOS 0.35µm SiGe

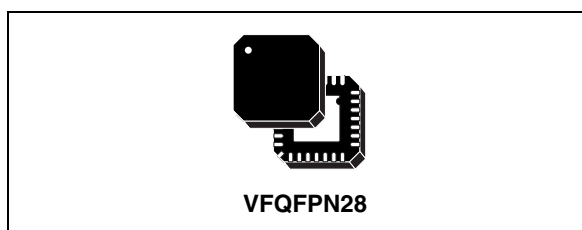

### Applications

- 2.5G and 3G Cellular Infrastructure Equipment
- CATV Equipment
- Instrumentation and Test Equipment
- Other Wireless Communication Systems

### Description

The STMicroelectronics STW81101 is an integrated RF synthesizer with voltage controlled oscillators (VCOs). Showing high performance, high integration, low power, and multi-band performances, STW81101 is a low cost one chip alternative to discrete PLL and VCOs solutions.

STW81101 includes an Integer-N frequency synthesizer and two fully integrated VCOs featuring low phase noise performance and a noise floor of -154dBc/Hz. The combination of wide frequency range VCOs (thanks to center-frequency calibration over 32 sub-bands) and multiple output options (direct output, divided by 2 or divided by 4) allows to cover the 825MHz-1100MHz, the 1650MHz-2200MHz and the 3300MHz-4400MHz bands.

The STW81101 is designed with STMicroelectronics advanced 0.35µm SiGe process.

### Order codes

Part number	Temp range, °C	Package	Packing
STW81101AT	-40 to 85	VFQFPN28	Tray
STW81101ATR	-40 to 85	VFQFPN28	Tape & Reel

# Contents

- 1      Block diagram and pin configuration ..... 6**
  - 1.1    Block diagram ..... 6
  - 1.2    Pin configuration ..... 7
  
- 2      Electrical specifications ..... 9**
  - 2.1    Absolute maximum ratings ..... 9
  - 2.2    Operating conditions ..... 9
  - 2.3    Digital logic levels ..... 9
  - 2.4    Electrical characteristics ..... 10
  - 2.5    Phase noise specification ..... 11
  
- 3      Typical performance characteristics ..... 14**
  
- 4      General description ..... 16**
  - 4.1    Circuit description ..... 16
    - 4.1.1    Reference input stage ..... 16
    - 4.1.2    Reference divider ..... 16
    - 4.1.3    Prescaler ..... 16
    - 4.1.4    A and B counters ..... 17
    - 4.1.5    Phase frequency detector (PFD) ..... 17
    - 4.1.6    Lock detect ..... 18
    - 4.1.7    Charge pump ..... 18
    - 4.1.8    Voltage controlled oscillators ..... 19
      - VCO Selection .....19
      - VCO Frequency Calibration .....19
      - VCO Voltage Amplitude Control .....20
  
- 5      I<sup>2</sup>C bus interface ..... 21**
  - 5.1    General features ..... 21
    - 5.1.1    Power ON reset ..... 21
    - 5.1.2    Data validity ..... 21
    - 5.1.3    START condition ..... 21
    - 5.1.4    STOP condition ..... 21
    - 5.1.5    Byte format and acknowledge ..... 22

5.1.6	Device addressing	22
5.1.7	Single-byte write mode	22
5.1.8	Multi-byte write mode	23
5.1.9	Current byte address read	23
5.2	Timing specification	23
5.2.1	Ack	24
5.3	I <sup>2</sup> C registers	25
5.3.1	FUNCTIONAL_MODE	25
5.3.2	B_COUNTER	26
5.3.3	A_COUNTER	26
5.3.4	REF_DIVIDER	26
5.3.5	CONTROL	26
5.3.6	CALIBRATION	27
5.3.7	READ-ONLY register	27
5.4	VCO calibration procedure	27
<b>6</b>	<b>SPI digital interface</b>	<b>29</b>
6.1	General features	29
6.2	Timing specification	30
6.3	Bits table	31
6.4	VCO calibration procedure	33
<b>7</b>	<b>Application information</b>	<b>34</b>
7.1	Direct Output	34
7.2	Divided by 2 Output	36
7.3	Divided by 4 Output	37
7.4	Evaluation Kit	38
<b>8</b>	<b>Application diagram</b>	<b>39</b>
<b>9</b>	<b>Package information</b>	<b>40</b>
<b>10</b>	<b>Revision history</b>	<b>41</b>

## List of tables

Table 1.	Pin description . . . . .	7
Table 2.	Absolute maximum ratings . . . . .	9
Table 3.	Operating conditions . . . . .	9
Table 4.	Digital logic levels . . . . .	9
Table 5.	Electrical characteristics . . . . .	10
Table 6.	Phase noise specification . . . . .	11
Table 7.	Current value vs selection . . . . .	18
Table 8.	Voltage level expected on the resonator nodes . . . . .	20
Table 9.	Single-byte write mode . . . . .	23
Table 10.	Multi-byte write mode . . . . .	23
Table 11.	Current Byte Address Read . . . . .	23
Table 12.	Data and clock . . . . .	23
Table 13.	Start and stop . . . . .	24
Table 14.	Ack . . . . .	24
Table 15.	Write-only registers list . . . . .	25
Table 16.	Different functional mode of the FUNCTIONAL_MODE register . . . . .	25
Table 17.	SPI data structure (MSB is sent first) . . . . .	30
Table 18.	Address decoder and outputs . . . . .	30
Table 19.	SPI Timing specification . . . . .	30
Table 20.	Bits . . . . .	31
Table 21.	Order code of the evaluation kit . . . . .	38
Table 22.	Document revision history . . . . .	41

## List of figures

Figure 1.	Block diagram . . . . .	6
Figure 2.	Pin connection (top view) . . . . .	7
Figure 3.	VCO A (Direct output) closed loop phase noise at 3.6GHz with $F_{STEP}=400KHz$ ( $F_{PFD}=400KHz$ ). . . . .	14
Figure 4.	VCO B (Direct output) closed loop phase noise at 4.0GHz with $F_{STEP}=400KHz$ ( $F_{PFD}=400KHz$ ). . . . .	14
Figure 5.	VCO A (Div. by 2 output) closed loop phase noise at 1.8GHz with $F_{STEP}=200KHz$ ( $F_{PFD}=400KHz$ ). . . . .	14
Figure 6.	VCO B (Div. by 2 output) closed loop phase noise at 2.0GHz with $F_{STEP}=200KHz$ ( $F_{PFD}=400KHz$ ). . . . .	14
Figure 7.	VCO A (Div. by 4 output) closed loop phase noise at 900MHz with $F_{STEP}=100KHz$ ( $F_{PFD}=400KHz$ ). . . . .	15
Figure 8.	VCO B (Div. by 4 output) closed loop phase noise at 1.0GHz with $F_{STEP}=100KHz$ ( $F_{PFD}=400KHz$ ). . . . .	15
Figure 9.	PFD Frequency Spurs (Div. by 2 Output; $F_{PFD}=400KHz$ ) . . . . .	15
Figure 10.	PFD Frequency Spurs (Div. by 4 Output; $F_{PFD}=400KHz$ ) . . . . .	15
Figure 11.	Reference Frequency Input Buffer . . . . .	16
Figure 12.	VCO Divider Diagram . . . . .	17
Figure 13.	PFD diagram . . . . .	18
Figure 14.	Loop filter connection . . . . .	19
Figure 15.	VCO Sub-Bands Frequency Characteristics . . . . .	19
Figure 16.	Data validity . . . . .	21
Figure 17.	Start and Stop condition . . . . .	22
Figure 18.	Byte format and acknowledge . . . . .	22
Figure 19.	Data and clock . . . . .	23
Figure 20.	Start and stop . . . . .	24
Figure 21.	Ack . . . . .	24
Figure 22.	SPI input and output bit order . . . . .	29
Figure 23.	SPI Timing specification . . . . .	30
Figure 24.	Differential/single ended output network in the 3.3 - 4.4GHz range (MATCH_LC_LUMP_4G_DIFF.dsn) . . . . .	34
Figure 25.	LC lumped balun and matching network (MATCH_LC_LUMP_4G.dsn) . . . . .	35
Figure 26.	Microstrip line and lumped matching network (MATCH_4G_HYBRID.dsn) . . . . .	35
Figure 27.	Differential/single ended output network in the 1.65 - 2.2GHz range (MATCH_LC_LUMP_2G_DIFF.dsn) . . . . .	36
Figure 28.	LC lumped balun for divided by 2 output (MATCH_LC_LUMP_2G.dsn) . . . . .	36
Figure 29.	Lumped output matching for divided by 2 output (MATCH_LC_BAL_2G.dsn) . . . . .	37
Figure 30.	LC lumped balun for the divided by 4 output (MATCH_LC_LUMP_1G.dsn) . . . . .	37
Figure 31.	Lumped output matching for divided by 4 output (MATCH_LC_BAL_1G.dsn) . . . . .	38
Figure 32.	Application diiagram . . . . .	39
Figure 33.	VFQFPN28 Mechanical Data & Package Dimensions . . . . .	40

# 1 Block diagram and pin configuration

## 1.1 Block diagram

Figure 1. Block diagram

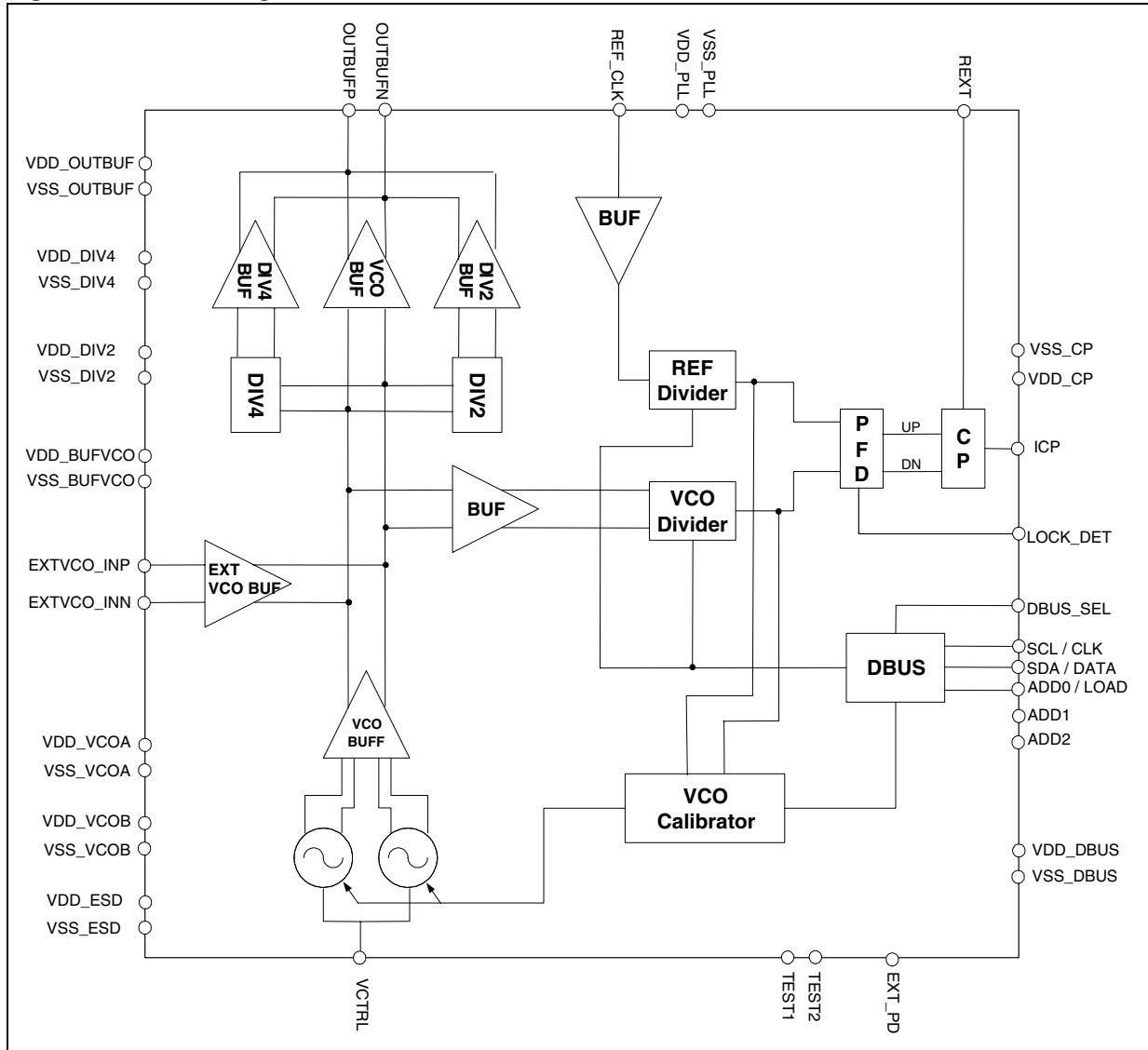

## 1.2 Pin configuration

Figure 2. Pin connection (top view)

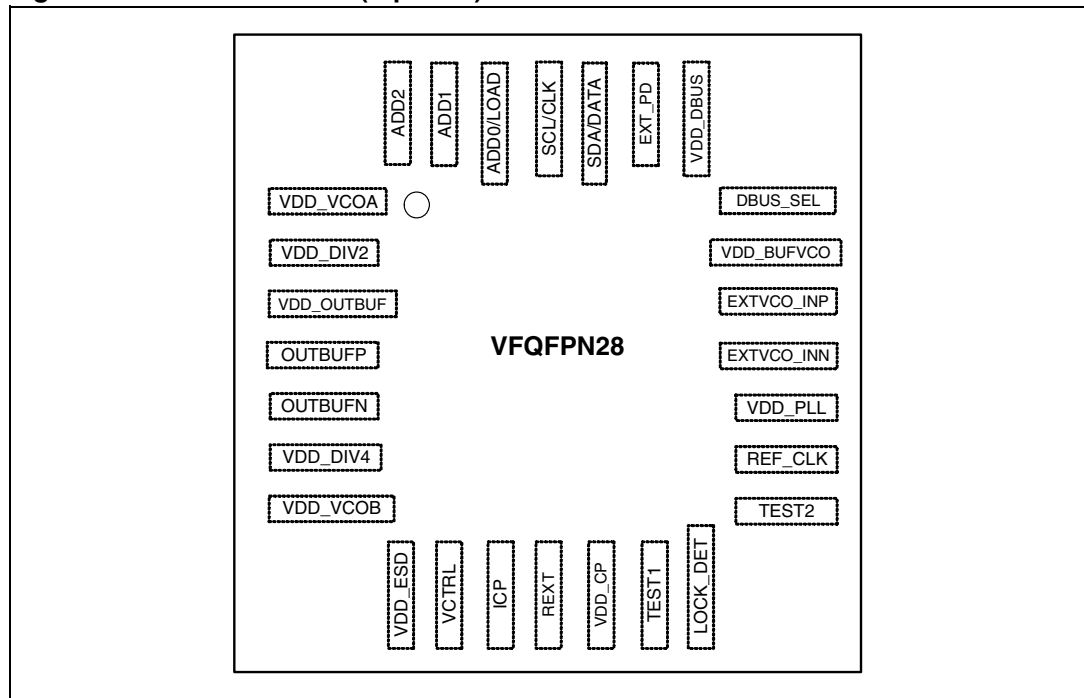

Table 1. Pin description

Pin No	Name	Description	Observation
1	VDD_VCOA	VCOA power supply	
2	VDD_DIV2	Divider by 2 power supply	
3	VDD_OUTBUF	Output buffer power supply	
4	OUTBUFP	LO buffer positive output	Open collector
5	OUTBUFN	LO buffer negative output	Open collector
6	VDD_DIV4	Divider by 4 power supply	
7	VDD_VCOB	VCOB power supply	
8	VDD_ESD	ESD positive rail power supply	
9	VCTRL	VCO control voltage	
10	ICP	PLL charge pump output	
11	REXT	External resistance connection for PLL charge pump	
12	VDD_CP	Power supply for charge pump	
13	TEST1	Test input 1	Test purpose only; must be connected to GND
14	LOCK_DET	Lock detector	CMOS Output

Table 1. Pin description (continued)

Pin No	Name	Description	Observation
15	TEST2	Test input 2	Test purpose only; must be connected to GND
16	REF_CLK	Reference clock input	
17	VDD_PLL	PLL digital power supply	
18	EXTVCO_INN	External VCO negative input	Test purpose only; must be connected to GND
19	EXTVCO_INP	External VCO positive input	Test purpose only; must be connected to GND
20	VDD_BUFVCO	VCO buffer power supply	
21	DBUS_SEL	Digital Bus Interface select	CMOS Input
22	VDD_DBUS	SPI and I <sup>2</sup> C bus power supply	
23	EXT_PD	Power down hardware	CMOS Input
24	SDA/DATA	I2CBUS/SPI data line	CMOS Bidir Schmitt triggered
25	SCL/CLK	I2CBUS/SPI clock line	CMOS Input
26	ADD0/LOAD	I2CBUS address select pin/ SPI load line	CMOS Input
27	ADD1	I2CBUS address select pin	CMOS Input
28	ADD2	I2CBUS address select pin	CMOS Input

## 2 Electrical specifications

### 2.1 Absolute maximum ratings

Table 2. Absolute maximum ratings

Symbol	Parameter	Values	Unit
$AV_{CC}$	Analog Supply voltage	0 to 4.6	V
$DV_{CC}$	Digital Supply voltage	0 to 4.6	V
$T_{stg}$	Storage temperature	+150	°C
ESD	Electrical Static Discharge		
	- HBM <sup>(1)</sup>	4	KV
	- CDM-JEDEC Standard	1.5	
- MM	0.2		

1. The maximum rating of the ESD protection circuitry on pin 4 and pin 5 is 1KV.

### 2.2 Operating conditions

Table 3. Operating conditions

Symbol	Parameter	Test conditions	Min	Typ	Max	Unit
$AV_{CC}$	Analog Supply voltage		3.0	3.3	3.6	V
$DV_{CC}$	Digital Supply voltage		3.0	3.3	3.6	V
$I_{CC}$	Current Consumption				100	mA
$T_{amb}$	Operating ambient temperature		-40		85	°C
$T_j$	Maximum junction temperature				125	°C
$R_{th j-amb}$	Junction to ambient package thermal resistance	Multilayer JEDEC board		35		°C/W

### 2.3 Digital logic levels

Table 4. Digital logic levels

Symbol	Parameter	Test conditions	Min	Typ	Max	Unit
$V_{il}$	Low level input voltage				0.2*Vdd	V
$V_{ih}$	High level input voltage		0.8*Vdd			V
$V_{hyst}$	Schmitt trigger hysteresis		0.8			V
$V_{ol}$	Low level output voltage				0.4	V
$V_{oh}$	High level output voltage		0.85*Vdd			V

## 2.4 Electrical characteristics

**Table 5. Electrical characteristics**

All the Electrical Specifications are intended at 3.3V supply Voltage.

Symbol	Parameter	Test conditions	Min	Typ	Max	Unit
<b>OUTPUT FREQUENCY RANGE</b>						
F <sub>OUTA</sub>	Output Frequency Range with VCOA	Direct Output	3300		3900	MHz
		Divider by 2	1650		1950	MHz
		Divider by 4	825		975	MHz
F <sub>OUTB</sub>	Output Frequency Range with VCOB	Direct Output	3800		4400	MHz
		Divider by 2	1900		2200	MHz
		Divider by 4	950		1100	MHz
<b>VCO DIVIDERS</b>						
N	VCO Divider Ratio	Prescaler 16/17	256		65551	
		Prescaler 19/20	361		77836	
<b>REFERENCE CLOCK and PHASE FREQUENCY DETECTOR</b>						
f <sub>ref</sub>	Reference input frequency		10		200	MHz
	Reference input sensitivity		0.35	1	1.5	V <sub>peak</sub>
R	Reference Divider Ratio		2		1023	
f <sub>PFD</sub>	PFD input frequency				16	MHz
f <sub>step</sub>	Frequency step <sup>(1)</sup>	Prescaler 16/17	F <sub>OUT</sub> /65551		F <sub>OUT</sub> /256	Hz
		Prescaler 19/20	F <sub>OUT</sub> /77836		F <sub>OUT</sub> /361	Hz
<b>CHARGE PUMP</b>						
I <sub>CP</sub>	ICP sink/source <sup>(2)</sup>	3bit programmable			5	mA
V <sub>OCP</sub>	Output voltage compliance range		0.4		V <sub>dd</sub> -0.3	V
	Spurious <sup>(3)</sup>	Direct Output		-76		dBc
		Divider by 2		-82		dBc
		Divider by 4		-88		dBc
<b>VCOs</b>						
K <sub>VCOA</sub>	VCOA sensitivity <sup>(4)</sup>	Sub-Band 00000	90	105	115	MHz/V
		Sub-Band 01111	55	70	85	MHz/V
		Sub-Band 11111	35	45	55	MHz/V
K <sub>VCOB</sub>	VCOB sensitivity <sup>(4)</sup>	Sub-Band 00000	90	105	115	MHz/V
		Sub-Band 01111	55	70	85	MHz/V
		Sub-Band 11111	35	45	55	MHz/V
	VCO A Pushing <sup>(4)</sup>			8	12	MHz/V
	VCO B Pushing <sup>(4)</sup>			8	12	MHz/V

**Table 5. Electrical characteristics (continued)**

All the Electrical Specifications are intended at 3.3V supply Voltage.

Symbol	Parameter	Test conditions	Min	Typ	Max	Unit
V <sub>CTRL</sub>	VCO control voltage <sup>(4)</sup>		0.4		3	V
	LO Harmonic Spurious <sup>(4)</sup>				-20	dBc
	VCO current consumption			25		mA
	VCO buffer consumption			15		mA
	DIVIDER by 2 consumption			18		mA
	DIVIDER by 4 consumption			14		mA
<b>LO OUTPUT BUFFER</b>						
	Output level			0		dBm
	Return Loss <sup>(4)</sup>	Matched to 50ohm		15		dB
	Current Consumption	DIV4 Buff		26		mA
		DIV2 Buff		23		mA
		Direct Output		37		mA
<b>EXTERNAL VCO (Test purpose only)</b>						
	Frequency range		3.3		4.4	GHz
	Input level		0		+6	dBm
	Current Consumption	VCO Internal Buffer		15		μA
<b>PLL MISCELLANEOUS</b>						
	Current Consumption	Input Buffer, Prescaler, Digital Dividers, misc.		12		mA
	Lock up time <sup>(4)</sup>	40 KHz PLL bandwidth; within 1 ppm of frequency error		150		μs

1. The frequency step is related to the PFD input frequency as follows:

- $f_{\text{step}} = f_{\text{PFD}}$  for Direct Output
- $f_{\text{step}} = f_{\text{PFD}}/2$  for Divided by 2 Output
- $f_{\text{step}} = f_{\text{PFD}}/4$  for Divided by 4 Output

2. see relationship between ICP and REXT in the Circuit Description section (Charge Pump)

3. PFD frequency leakage (400KHz) and harmonics

4. Guaranteed by design and characterization.

## 2.5 Phase noise specification

**Table 6. Phase noise specification**

Parameter	Test conditions	Min	Typ	Max	Unit
<b>PHASE NOISE PERFORMANCE<sup>(1)</sup></b>					
<b>In Band Phase Noise Floor – Closed Loop<sup>(2)</sup></b>					
Normalized In Band Phase Noise Floor	ICP=4mA, PLL BW = 50KHz; including reference clock contribution		-220		dBc/Hz

**Table 6. Phase noise specification (continued)**

Parameter	Test conditions	Min	Typ	Max	Unit
In Band Phase Noise Floor Direct Output	ICP=4mA, PLL BW = 50KHz; including reference clock contribution	$-220+20\log(N)+10\log(f_{PFD})$			dBc/Hz
In Band Phase Noise Floor Divider by 2		$-226+20\log(N)+10\log(f_{PFD})$			dBc/Hz
In Band Phase Noise Floor Divider by 4		$-232+20\log(N)+10\log(f_{PFD})$			dBc/Hz
<b>PLL Integrated Phase Noise – Direct Output</b>					
Integrated Phase Noise 100Hz to 40MHz	F <sub>OUT</sub> = 4 GHz, f <sub>PFD</sub> = 400KHz, f <sub>STEP</sub> =400 KHz, PLL BW = 35KHz, ICP=4mA		-38		dBc
			1.0		° rms
<b>PLL Integrated Phase Noise – Divider by 2</b>					
Integrated Phase Noise 100Hz to 40MHz	F <sub>OUT</sub> = 2 GHz, f <sub>PFD</sub> = 400KHz, f <sub>STEP</sub> =200 KHz, PLL BW = 35KHz, ICP=4mA		-44		dBc
			0.5		° rms
<b>PLL Integrated Phase Noise – Divider by 4</b>					
Integrated Phase Noise 100Hz to 40MHz	F <sub>OUT</sub> = 1 GHz, f <sub>PFD</sub> = 400KHz, f <sub>STEP</sub> =100 KHz, PLL BW = 35KHz, ICP=4mA		-50		dBc
			0.25		° rms
<b>VCO A Direct (3300MHz-3900MHz) – Open Loop<sup>(3)</sup></b>					
Phase Noise @ 1 KHz			-56		dBc/Hz
Phase Noise @ 10 KHz			-83		dBc/Hz
Phase Noise @ 100 KHz			-105		dBc/Hz
Phase Noise @ 1 MHz			-128		dBc/Hz
Phase Noise @ 10 MHz			-148		dBc/Hz
Phase Noise @ 40 MHz			-156		dBc/Hz
<b>VCO B Direct (3800MHz-4400MHz) – Open Loop<sup>(3)</sup></b>					
Phase Noise @ 1 KHz			-55		dBc/Hz
Phase Noise @ 10 KHz			-82		dBc/Hz
Phase Noise @ 100 KHz			-104		dBc/Hz
Phase Noise @ 1 MHz			-127		dBc/Hz
Phase Noise @ 10 MHz			-147		dBc/Hz
Phase Noise @ 40 MHz			-155		dBc/Hz
<b>VCO A with divider by 2 (1650MHz-1950MHz) – Open Loop<sup>(3)</sup></b>					
Phase Noise @ 1 KHz			-62		dBc/Hz
Phase Noise @ 10 KHz			-89		dBc/Hz
Phase Noise @ 100 KHz			-111		dBc/Hz
Phase Noise @ 1 MHz			-134		dBc/Hz

**Table 6. Phase noise specification (continued)**

Parameter	Test conditions	Min	Typ	Max	Unit
Phase Noise @ 10 MHz			-150		dBc/Hz
Phase Noise @ 20 MHz			-152		dBc/Hz
Phase Noise Floor @ 40 MHz			-154		dBc/Hz
<b>VCO B with divider by 2 (1900MHz-2200MHz) – Open Loop<sup>(3)</sup></b>					
Phase Noise @ 1 KHz			-61		dBc/Hz
Phase Noise @ 10 KHz			-88		dBc/Hz
Phase Noise @ 100 KHz			-110		dBc/Hz
Phase Noise @ 1 MHz			-133		dBc/Hz
Phase Noise @ 10 MHz			-150		dBc/Hz
Phase Noise @ 20 MHz			-152		dBc/Hz
Phase Noise Floor @ 40 MHz			-154		dBc/Hz
<b>VCO A with divider by 4 (825MHz-975MHz) – Open Loop<sup>(3)</sup></b>					
Phase Noise @ 1 KHz			-68		dBc/Hz
Phase Noise @ 10 KHz			-95		dBc/Hz
Phase Noise @ 100 KHz			-117		dBc/Hz
Phase Noise @ 1 MHz			-139		dBc/Hz
Phase Noise @ 10 MHz			-151		dBc/Hz
Phase Noise Floor @ 40 MHz			-154		dBc/Hz
<b>VCO B with divider by 4 (950MHz-1100MHz) – Open Loop<sup>(3)</sup></b>					
Phase Noise @ 1 KHz			-67		dBc/Hz
Phase Noise @ 10 KHz			-94		dBc/Hz
Phase Noise @ 100 KHz			-116		dBc/Hz
Phase Noise @ 1 MHz			-138		dBc/Hz
Phase Noise @ 10 MHz			-151		dBc/Hz
Phase Noise Floor @ 40 MHz			-154		dBc/Hz

1. Phase Noise SSB.  
VCO amplitude setting to value [10].  
All the closed-loop performances are specified using a Reference Clock signal at 76.8 MHz with phase noise of -135dBc/Hz @ 1KHz offset, -145dBc/Hz @ 10KHz offset and -149.5dBc/Hz of noise floor.
2. Normalized PN = Measured PN – 20log(N) – 10log(f<sub>PFD</sub>) where N is the VCO divider ratio (N=B\*P+A) and f<sub>PFD</sub> is the comparison frequency at the PFD input
3. Typical Phase Noise at centre band frequency

Upon request an Evaluation Kit is available including a powerful simulation tool (STWPLLSim) which allows to estimate very accurately the Phase Noise of the device according to the desired project parameters (VCO Frequency, Selected Output Stage, Reference Clock, Frequency Step, ...); refer to the Application Information ([Section 7](#)) for more details.

### 3 Typical performance characteristics

The phase noise is measured with the Agilent E5052A Signal Source Analyzer. All the closed-loop measurements are done with  $f_{\text{PFD}} = 400$  KHz and using a Reference Clock signal at 76.8 MHz with phase noise of  $-135\text{dBc/Hz}$  @ 1KHz offset,  $-145\text{dBc/Hz}$  @ 10KHz offset and  $-149.5\text{dBc/Hz}$  @ 1KHz of noise floor.

**Figure 3. VCO A (Direct output) closed loop phase noise at 3.6GHz with  $F_{\text{STEP}}=400\text{KHz}$  ( $F_{\text{PFD}}=400\text{KHz}$ )**

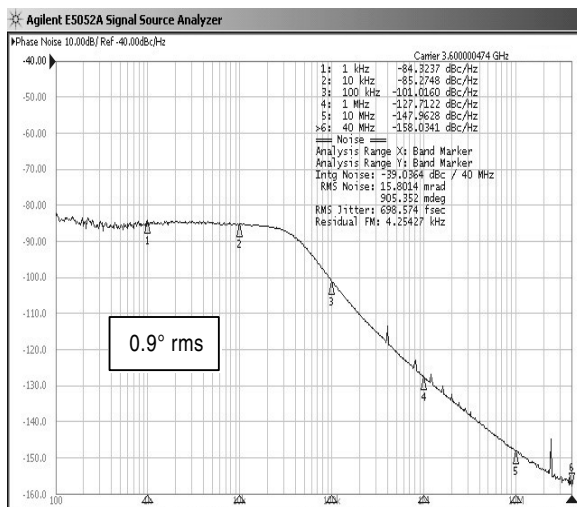

**Figure 4. VCO B (Direct output) closed loop phase noise at 4.0GHz with  $F_{\text{STEP}}=400\text{KHz}$  ( $F_{\text{PFD}}=400\text{KHz}$ )**

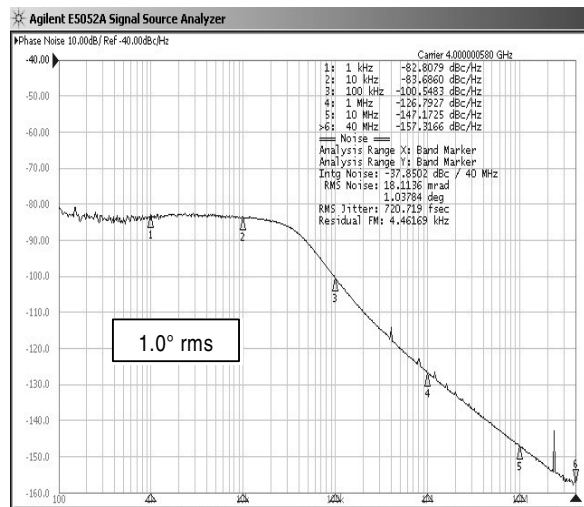

**Figure 5. VCO A (Div. by 2 output) closed loop phase noise at 1.8GHz with  $F_{\text{STEP}}=200\text{KHz}$  ( $F_{\text{PFD}}=400\text{KHz}$ )**

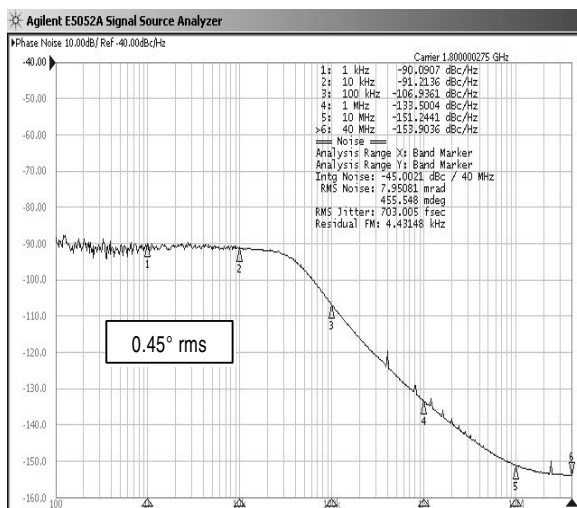

**Figure 6. VCO B (Div. by 2 output) closed loop phase noise at 2.0GHz with  $F_{\text{STEP}}=200\text{KHz}$  ( $F_{\text{PFD}}=400\text{KHz}$ )**

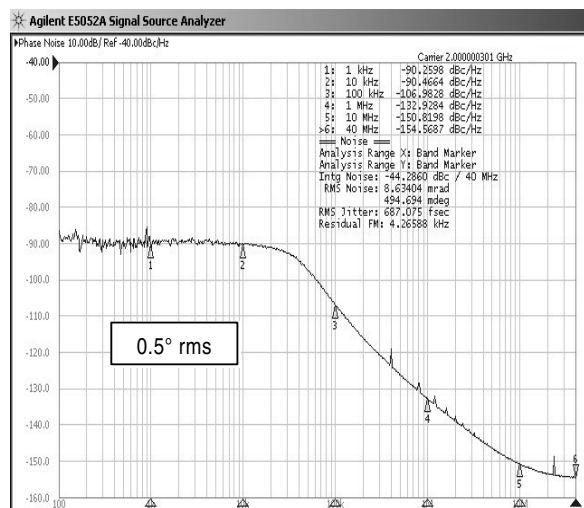

Figure 7. VCO A (Div. by 4 output) closed loop phase noise at 900MHz with  $F_{STEP}=100KHz$  ( $F_{PFD}=400KHz$ )

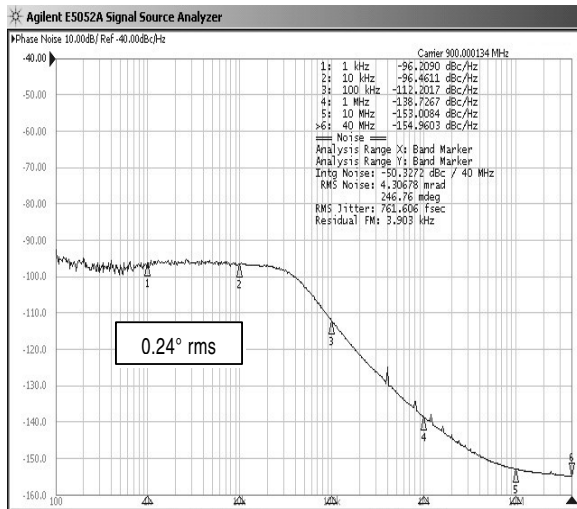

Figure 8. VCO B (Div. by 4 output) closed loop phase noise at 1.0GHz with  $F_{STEP}=100KHz$  ( $F_{PFD}=400KHz$ )

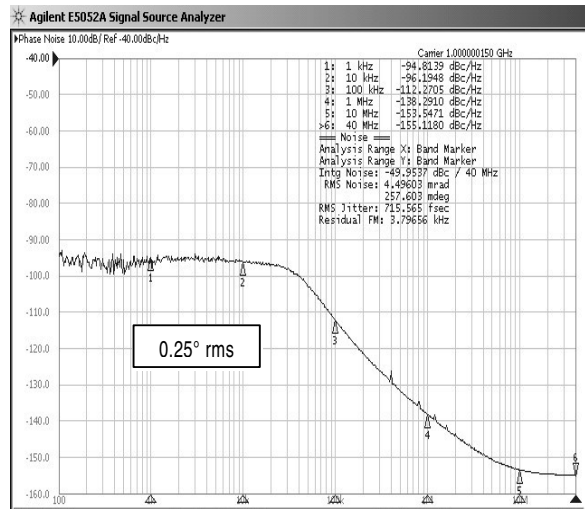

Figure 9. PFD Frequency Spurs (Div. by 2 Output;  $F_{PFD}=400KHz$ )

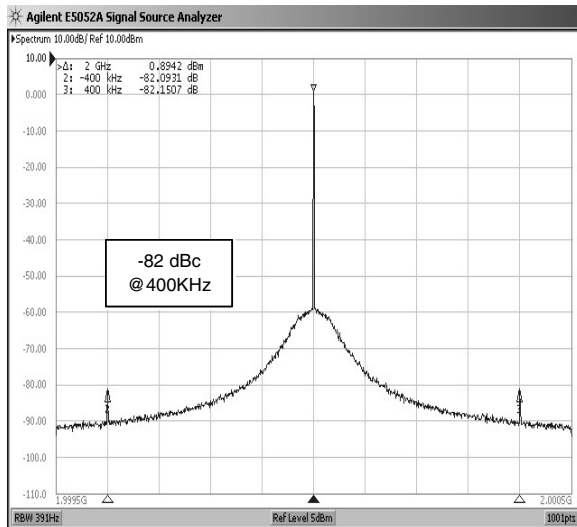
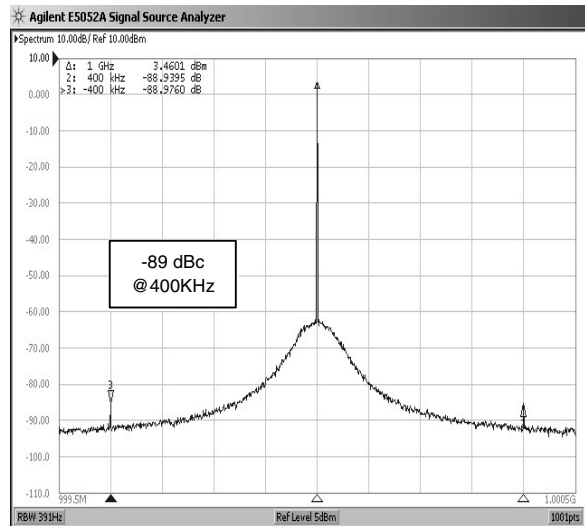

Figure 10. PFD Frequency Spurs (Div. by 4 Output;  $F_{PFD}=400KHz$ )



## 4 General description

The block diagram of [Figure 1](#) shows the different blocks, which have been integrated to achieve an integer-N PLL frequency synthesizer.

The STW81101 consists of 2 internal low-noise VCOs with buffer blocks, a divider by 2, a divider by 4, a low-noise PFD (Phase Frequency Detector), a precise charge pump, a 10-bit programmable reference divider, two programmable counters and a programmable dual-modulus prescaler. The A-counter (5 bits) and B counter (12 bits) counters, in conjunction with the dual modulus prescaler  $P/P+1$  (16/17 or 19/20), implement an N integer divider, where  $N = B \cdot P + A$ . The division ratio of both reference and VCO dividers is controlled through the selected digital interface (I<sup>2</sup>C bus or SPI).

The selection of the digital interface type is done by the proper hardware connection of the pin DBUS\_SEL (0 V for I<sup>2</sup>C bus, 3.3 V for SPI).

All devices operate with a power supply of 3.3 V and can be powered down when not in use.

### 4.1 Circuit description

#### 4.1.1 Reference input stage

The reference input stage is shown in [Figure 11](#). The resistor network feeds a DC bias at the Fref input while the inverter used as the frequency reference buffer is AC coupled.

**Figure 11. Reference Frequency Input Buffer**

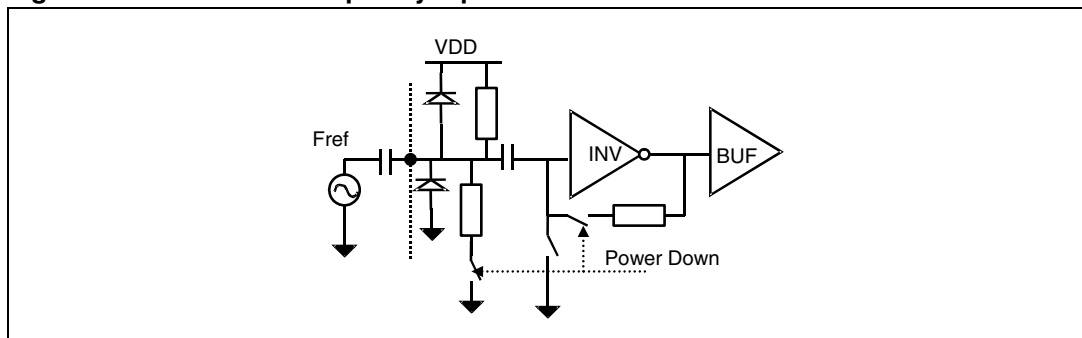

#### 4.1.2 Reference divider

The 10-bit programmable reference counter allows the input reference frequency to be divided to produce the input clock to the PFD. The division ratio is programmed through the digital interface.

#### 4.1.3 Prescaler

The dual-modulus prescaler  $P/P+1$  takes the CML clock from the VCO buffer and divides it down to a manageable frequency for the CMOS A and B counters. The modulus (P) is programmable and can be set to 16 or 19. It is based on a synchronous 4/5 core which division ratio depends on the state of the modulus input.

#### 4.1.4 A and B counters

The A (5 bits) and B (12 bits) counters, in conjunction with the selected dual modulus (16/17 or 19/20) prescaler make it possible to generate output frequencies which are spaced only by the reference frequency divided by the reference division ratio. Thus, the division ratio and the VCO output frequency are given by these formulas:

$$N = B \cdot P + A$$

$$F_{\text{VCO}} = \frac{(B \cdot P + A) \cdot F_{\text{ref}}}{R}$$

where:

$F_{\text{VCO}}$ : output frequency of VCO.

P: modulus of dual modulus prescaler (16 or 19 selected through the digital interface).

B: division ratio of the main counter.

A: division ratio of the swallow counter.

$F_{\text{ref}}$ : input reference frequency.

R: division ratio of reference counter.

N: division ratio of PLL

For a correct work of the VCO divider, B must be strictly higher than A. A can take any value ranging from 0 to 31. The range of the N number can vary from 256 to 65551 (P=16) or from 361 to 77836 (P=19).

**Figure 12. VCO Divider Diagram**

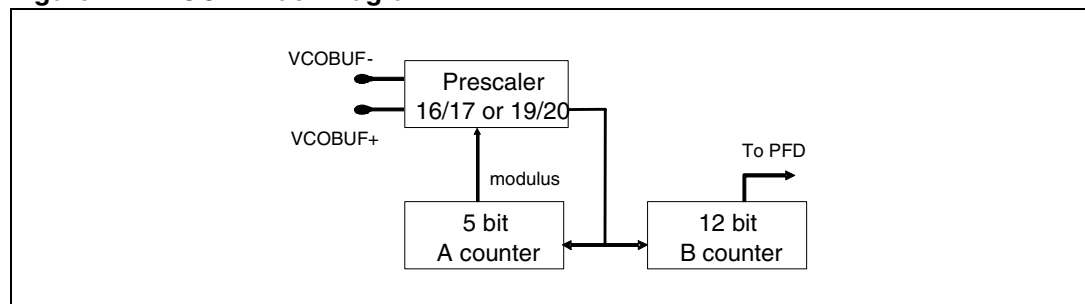

#### 4.1.5 Phase frequency detector (PFD)

The PFD takes inputs from the reference and the VCO dividers and produces an output proportional to the phase error. The PFD includes a delay gate that controls the width of the anti-backlash pulse. This pulse ensures that there is no dead zone in the PFD transfer function.

[Figure 13](#) is a simplified schematic of the PFD.

Figure 13. PFD diagram

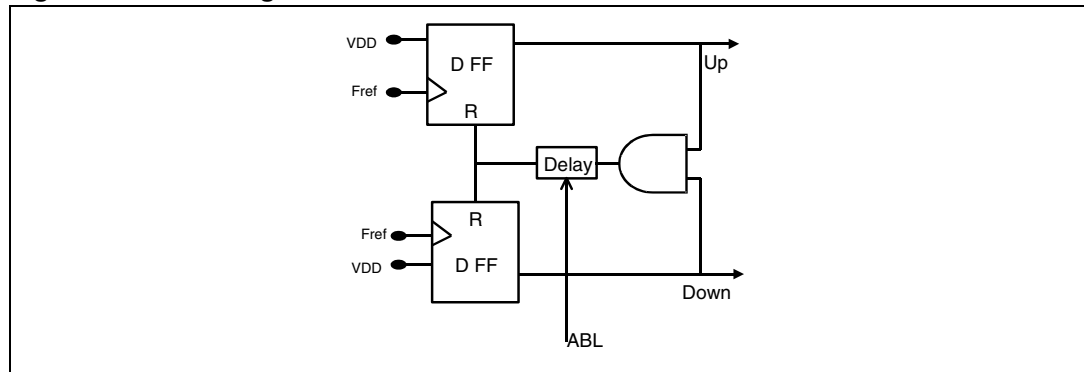

### 4.1.6 Lock detect

This signal indicates that the difference between rising edges of both UP and DOWN PFD signals is found to be shorter than the fixed delay (roughly 5 ns). Lock Detect signal is high when the PLL is locked. When Power Down is activated, Lock Detect is let to high level (Lock Detect consumes current only during PLL transients).

### 4.1.7 Charge pump

This block drives two matched current sources,  $I_{up}$  and  $I_{down}$ , which are controlled respectively by UP and DOWN PFD outputs. The nominal value of the output current is controlled by an external resistor (to be connected to the REXT input pin) and a selection among 8 by a 3 bit word.

The minimum value of the output current is:  $I_{MIN} = 2 \cdot V_{BG} / R_{EXT}$  ( $V_{BG} \sim 1.17$  V)

Table 7. Current value vs selection

CPSEL2	CPSEL1	CPSEL0	Current	Value for REXT=4.7 KΩ
0	0	0	$I_{MIN}$	0.5 mA
0	0	1	$2 \cdot I_{MIN}$	1.0 mA
0	1	0	$3 \cdot I_{MIN}$	1.5 mA
0	1	1	$4 \cdot I_{MIN}$	2.0 mA
1	0	0	$5 \cdot I_{MIN}$	2.5 mA
1	0	1	$6 \cdot I_{MIN}$	3.0 mA
1	1	0	$7 \cdot I_{MIN}$	3.5 mA
1	1	1	$8 \cdot I_{MIN}$	4.0 mA

Note: The current is output on pin ICP. During the VCO auto calibration, ICP and VCTRL pins are forced to VDD/2

Figure 14. Loop filter connection

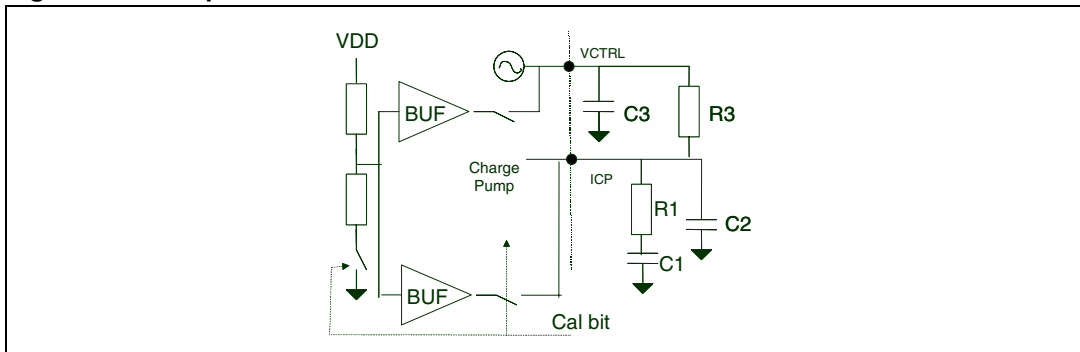

### 4.1.8 Voltage controlled oscillators

#### VCO Selection

Within STW81101 two low-noise VCOs are integrated to cover a wide band from 3300MHz to 4400MHz (direct output), from 1650MHz to 2200MHz (selecting divider by 2) and from 825MHz to 1100MHz (selecting divider by 4).

VCO A frequency range 3300MHz-3900MHz

VCO B frequency range 3800MHz-4400MHz

#### VCO Frequency Calibration

Both VCOs can operate on 32 frequency ranges that are selected by adding or subtracting capacitors to the resonator. These frequency ranges are intended to cover the wide band of operation and compensate for process variation on the VCO center frequency.

An automatic selection of the range is performed when the bit SERCAL rises from "0" to "1". The charge pump is inhibited and the pins ICP & VCTRL are at VDD/2 volts. Then the ranges are tested to select the one which with this VCO input voltage is the nearest to the desired output frequency ( $F_{out} = N \cdot F_{ref} / R$ ). When this selection is achieved the signal ENDCALB (which means End of Calibration) falls to "0", then the charge pump is enabled again and SERCAL should be reset to "0" before the next channel step. The PLL has just to perform fine adjustment around VDD/2 on the loop filter to reach  $F_{out}$ , which enables a fast settle.

Figure 15. VCO Sub-Bands Frequency Characteristics

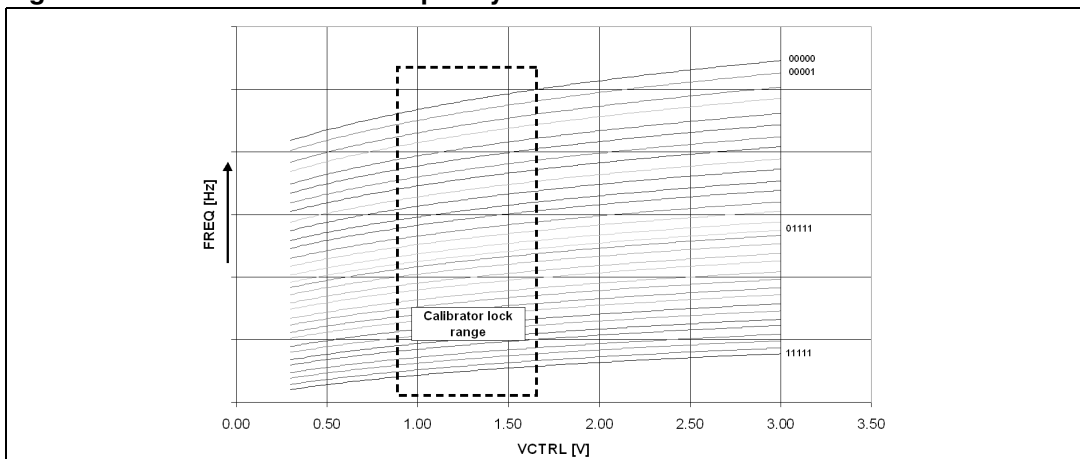

The SERCAL bit should be set to "1" at each division ratio change. It should be noted that in order to reset the autocalibrator State Machine after a power-up, and anyway before the first calibration, the INITCAL bit should be set to "1" and back to "0" (this operation is automatically performed by the Power On Reset circuitry). The calibration takes approximately 7 periods of the PFD Frequency.

The maximum allowed  $f_{PFD}$  to perform the calibration process is 1 MHz. Using an higher  $F_{PFD}$  the following procedure should be adopted:

1. Calibrate the VCO at the desired frequency with an  $f_{PFD}$  less than 1 MHz
2. Set the A, B and R dividers ratio for the desired  $f_{PFD}$

### VCO Voltage Amplitude Control

The bits A0 and A1 control the voltage swing of the VCO. The following table gives the voltage level expected on the resonator nodes.

**Table 8. Voltage level expected on the resonator nodes**

Code A[1:0]	Differential output voltage (Vp)
00	1.1
01	1.3
10	1.9
11	2.1

## 5 I<sup>2</sup>C bus interface

The I<sup>2</sup>C bus interface is selected by hardware connection of the pin #21 (DBUS\_SEL) to 0 V.

Data transmission from microprocessor to the STW81101 takes place through the 2 wires (SDA and SCL) I<sup>2</sup>C-BUS interface. The STW81101 is always a slave device.

The I<sup>2</sup>C-bus protocol defines any device that sends data on to the bus as a transmitter and any device that reads the data as receiver. The device that controls the data transfer is known as the Master and the others as the slave. The master will always initiate the transfer and will provide the serial clock for synchronization.

### 5.1 General features

#### 5.1.1 Power ON reset

The device at Power ON is able to configure itself to a fixed configuration, with all programmable bits set to factory default setting.

#### 5.1.2 Data validity

Data changes on the SDA line must only occur when the SCL is LOW. SDA transitions while the clock is HIGH are used to identify START or STOP condition.

**Figure 16. Data validity**

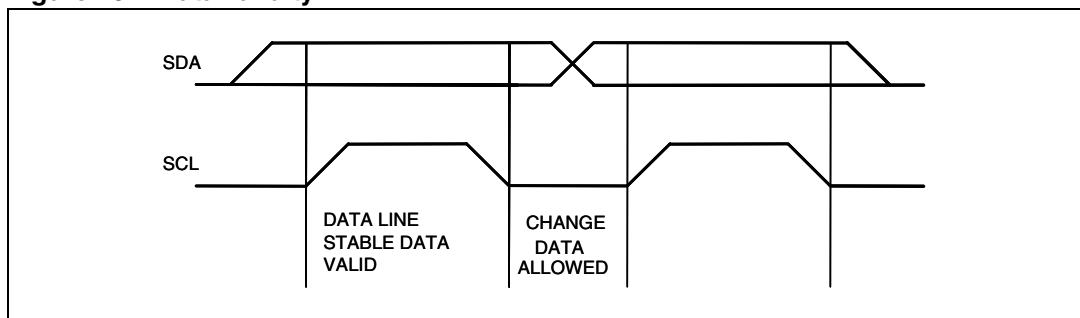

#### 5.1.3 START condition

A Start condition is identified by a HIGH to LOW transition of the data bus SDA while the clock signal SCL is stable in the HIGH state. A Start condition must precede any command for data transfer.

#### 5.1.4 STOP condition

A LOW to HIGH transition of the data bus SDA identifies stop while the clock signal SCL is stable in the HIGH state. A STOP condition terminates communications between the STW81101 and the Bus Master.

Figure 17. Start and Stop condition

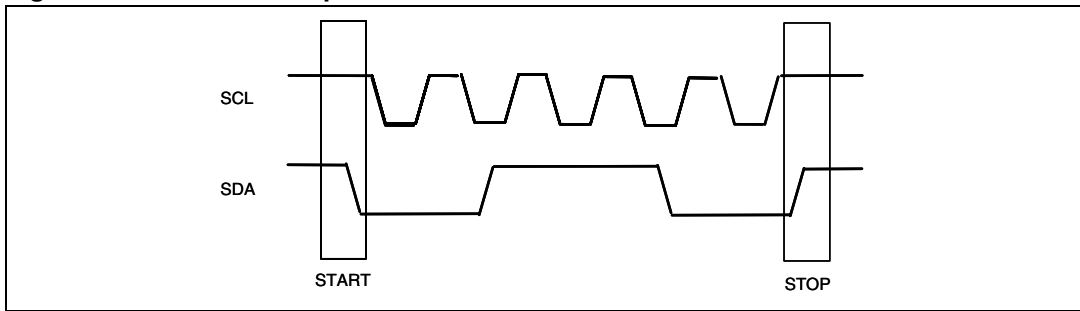

### 5.1.5 Byte format and acknowledge

Every byte transferred on the SDA line must contain 8 bits. Each byte must be followed by an acknowledge bit. The MSB is transferred first.

An acknowledge bit is used to indicate a successful data transfer. The bus transmitter, either master or slave, will release the SDA bus after sending 8 bits of data. During the 9th clock pulse the receiver pulls the SDA low to acknowledge the receipt of 8 bits data.

Figure 18. Byte format and acknowledge

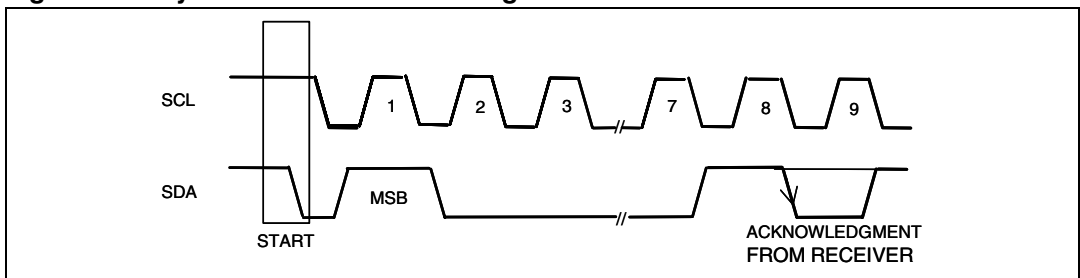

### 5.1.6 Device addressing

To start the communication between the Master and the STW81101, the master must initiate with a start condition. Following this, the master sends onto the SDA line 8 bits (MSB first) corresponding to the device select address and read or write mode.

The first 7 MSB's are the device address identifier, corresponding to the I<sup>2</sup>C-Bus definition. For the STW81101 the address is set as "1100A<sub>2</sub>A<sub>1</sub>A<sub>0</sub>", 3bits programmable. The 8th bit (LSB) is the read or write operation bit (RW; set to 1 in read mode and to 0 in write mode).

After a START condition the STW81101 identifies on the bus the device address and, if matched, it will acknowledge the identification on SDA bus during the 9th clock pulse.

### 5.1.7 Single-byte write mode

Following a START condition the master sends a device select code with the RW bit set to 0. The STW81101 gives an acknowledge and waits for the internal sub-address (1 byte). This byte provides access to any of the internal registers.

After the reception of the sub-address internal byte the STW81101 again responds with an acknowledge. A single-byte write to sub-address 00H will change the "FUNCTIONAL\_MODE" register, so a single-byte write with sub-address 04H will change the "CONTROL" register and so on.

**Table 9. Single-byte write mode**

S	1100A <sub>2</sub> A <sub>1</sub> A <sub>0</sub>	0	ack	sub-address byte	ack	DATA IN	ack	P
---	--------------------------------------------------	---	-----	------------------	-----	---------	-----	---

### 5.1.8 Multi-byte write mode

The multi-byte write mode can start from any internal address. The master sends the data bytes and each one is acknowledged. The master terminates the transfer by generating a STOP condition.

The sub-address decides the starting byte. A multi-byte with sub-address 01H and 2 DATA\_IN bytes will change the "B\_COUNTER" and "A\_COUNTER" registers (01H,02H), so a multi-byte with sub-address 00H and and 6 DATA\_IN bytes will change all the STW81101 registers.

**Table 10. Multi-byte write mode**

S	1100A <sub>2</sub> A <sub>1</sub> A <sub>0</sub>	0	ack	sub-address byte	ack	DATA IN	ack	...	DATA IN	ack	P
---	--------------------------------------------------	---	-----	------------------	-----	---------	-----	-----	---------	-----	---

### 5.1.9 Current byte address read

In the current byte address read mode, following a START condition, the master sends the device address with the rw bit set to 1 (No sub-address is needed as there is only 1 byte read register). The STW81101 acknowledges this and outputs the data byte. The master does not acknowledge the received byte, but terminates the transfer with a STOP condition.

**Table 11. Current Byte Address Read**

S	1100 A <sub>2</sub> A <sub>1</sub> A <sub>0</sub>	1	ack	DATA OUT	No ack	P
---	---------------------------------------------------	---	-----	----------	--------	---

## 5.2 Timing specification

**Figure 19. Data and clock**

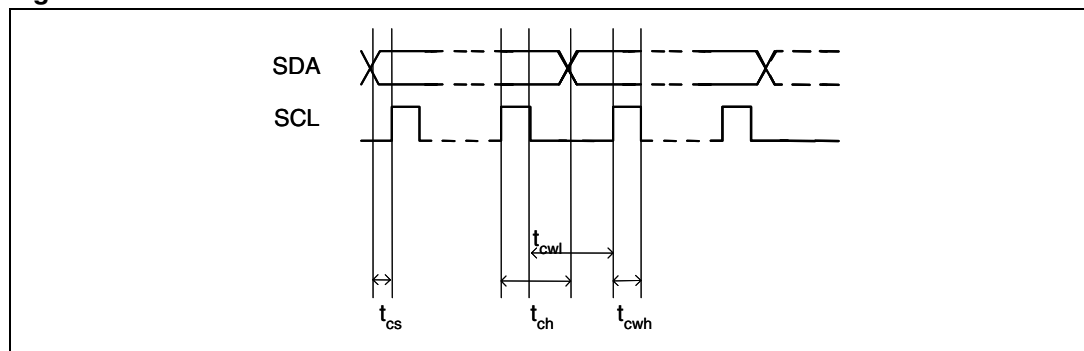

**Table 12. Data and clock**

Symbol	Parameter	Minimum time (ns)
$T_{cs}$	Data to clock set up time	2
$T_{ch}$	Data to clock hold time	2
$T_{cwh}$	Clock pulse width high	10
$T_{cwl}$	Clock pulse width low	5

Figure 20. Start and stop

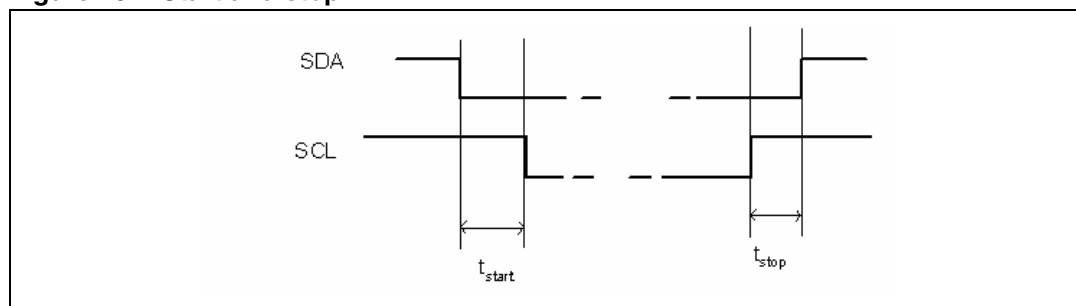

Table 13. Start and stop

Symbol	Parameter	Minimum time (ns)
$T_{start}$	Clock to data start time	2
$T_{stop}$	Data to clock down stop time	2

### 5.2.1 Ack

Figure 21. Ack

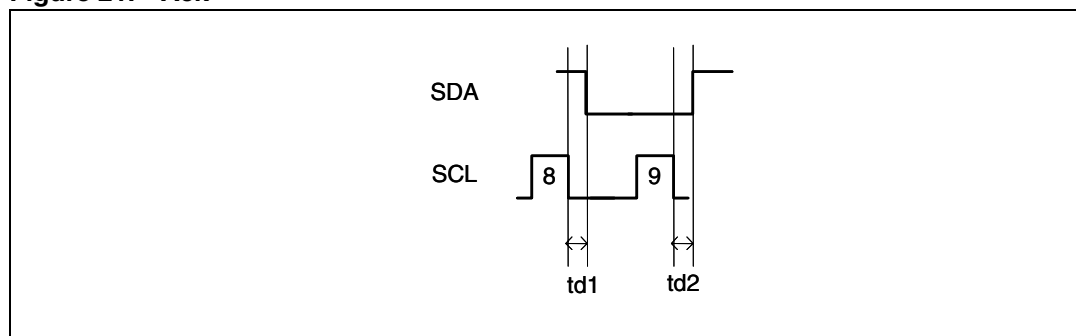

Table 14. Ack

Symbol	Parameter	Minimum time (ns)
$T_{d1}$	Ack begin delay	2
$T_{d2}$	Ack end delay	2

## 5.3 I<sup>2</sup>C registers

STW81101 has 6 write-only registers and 1 read-only register.

The following table gives a short description of the write-only registers list.

**Table 15. Write-only registers list**

HEX CODE	DEC CODE	DESCRIPTION
0x00	0	FUNCTIONAL_MODE
0x01	1	B_COUNTER
0x02	2	A_COUNTER
0x03	3	REF_DIVIDER
0x04	4	CONTROL
0x05	5	CALIBRATION

### 5.3.1 FUNCTIONAL\_MODE

MSB				LSB			
b7	b6	b5	b4	b3	b2	b1	b0
PD6	PD5	PD4	PD3	PD2	PD1	PD0	B11

FUNCTIONAL\_MODE register is used to select different functional mode for the STW81101 synthesizer according to the following table:

**Table 16. Different functional mode of the FUNCTIONAL\_MODE register**

Decimal value	Description
0	Power down mode
1	Enable VCO A, output frequency divided by 2
2	Enable VCO B, output frequency divided by 2
3	Enable external VCO, output frequency divided by 2
4	Enable VCO A, output frequency divided by 4
5	Enable VCO B, output frequency divided by 4
6	Enable external VCO, output frequency divided by 4
7	Enable VCO A, direct output
8	Enable VCO B, direct output
9	Enable external VCO, direct output

### 5.3.2 B\_COUNTER

MSB				LSB			
b7	b6	b5	b4	b3	b2	b1	b0
B10	B9	B8	B7	B6	B5	B4	B3

B[10:3]. Counter value (bit B11 in the previous register, bits B[2:0] in the next register)

### 5.3.3 A\_COUNTER

MSB				LSB			
b7	b6	b5	b4	b3	b2	b1	b0
B2	B1	B0	A4	A3	A2	A1	A0

Bits B[2:0] for B Counter, A Counter value.

### 5.3.4 REF\_DIVIDER

MSB				LSB			
b7	b6	b5	b4	b3	b2	b1	b0
R9	R8	R7	R6	R5	R4	R3	R2

Reference Clock divider ratio R[9:1] (bits R1, R0 in the next register).

### 5.3.5 CONTROL

MSB				LSB			
b7	b6	b5	b4	b3	b2	b1	b0
R1	R0	PLL_ A1	PLL_ A0	CP SEL2	CP SEL1	CP SEL0	PSC_ SEL

The CONTROL register is used to set the Charge Pump current, the VCO output voltage amplitude and the Prescaler Modulus.

PLL\_A[1:0]: VCO amplitude

CPSEL[2:0]: Charge Pump output current

PSC\_SEL: Prescaler Modulus select ('0' for P=16, '1' for P=19)

The LO output frequency is programmed by setting the proper value for A,B and R according to the following formula:

$$F_{OUT} = D_R \cdot (B \cdot P + A) \cdot \frac{F_{REF\_CLK}}{R}$$

where  $D_R$  equals  $\begin{cases} 1 & \text{for Direct Output} \\ 0.5 & \text{for Output Divided by 2} \\ 0.25 & \text{for Output Divided by 4} \end{cases}$

and P is the selected Prescaler Modulus

### 5.3.6 CALIBRATION

MSB				LSB			
b7	b6	b5	b4	b3	b2	b1	b0
INIT CAL	SER CAL	SEL EXT CAL	CAL4	CAL3	CAL2	CAL1	CAL0

This register controls VCO calibrator.

INITCAL: resets the auto-calibrator State Machine (writing to "1" and back to "0")

SERCAL: at "1" starts the VCO auto-calibration (should be reset to "0" at the end of calibration)

SELEXTCAL: test purpose only; must be set to '0'

CAL[4:0]: test purpose only; must be set to '0'

### 5.3.7 READ-ONLY register

MSB				LSB			
b7	b6	b5	b4	b3	b2	b1	b0
DEV_ID1	DEV_ID0	LOCK_ DET	INT CAL4	INT CAL3	INT CAL2	INT CAL1	INT CAL0

This register is automatically addressed in the 'current byte address read mode'.

DEV\_ID[1:0]: device identifier bits; returns '00'

LOCK\_DET: "1" when PLL is locked

INTCAL[4:0]: internal value of the VCO control word

## 5.4 VCO calibration procedure

The calibration of the VCO center frequency is activated by a '0' to '1' transition of the SERCAL bit (CALIBRATION Register bit[6]).

In order to program properly the device, ensuring the VCO calibration, the following procedure is required before every channel change:

- a) Program all the Registers using a multi-byte write sequence with the desired settings (Functional Mode, B and A counters, R counter, VCO amplitude, Charge

Pump, Prescaler Modulus) and all the bits of the "CALIBRATION" Register (05H) set to '0'

- b) Program the "CALIBRATION" Register using a single-byte write sequence (sub-address 05H) with the SERCAL bit set to '1'

The maximum allowed PFD frequency ( $f_{\text{PFD}}$ ) to perform the calibration process is 1 MHz; if the desired  $f_{\text{PFD}}$  is higher than 1MHz the following steps are needed:

- Perform all the steps of the calibration procedure programming the desired VCO frequency with a proper setting of R, B and A counter so that  $f_{\text{PFD}}$  is  $\leq 1\text{MHz}$ .
- Program the device with the proper setting for the desired VCO and PFD frequencies according to the above step a) only.

## 6 SPI digital interface

### 6.1 General features

The SPI digital interface is selected by hardware connection of the pin #21 (DBUS\_SEL) to 3.3V.

The STW81101 IC is programmed by means of a high-speed serial-to-parallel interface with write option only. The 3-wires bus can be clocked at a frequency as high as 100MHz to allow fast programming of the registers containing the data for RF IC configuration.

The programming of the chip is done through serial words with whole length of 26 bits. The first 2 MSB represent the address of the registers. The others 24 LSB represent the value of the registers.

Each Data bit is stored in the internal shift register on the **rising edge** of the CLOCK signal.

On the **rising edge** of the LOAD signal the outputs of the selected register are sent to the device.

**Figure 22. SPI input and output bit order**

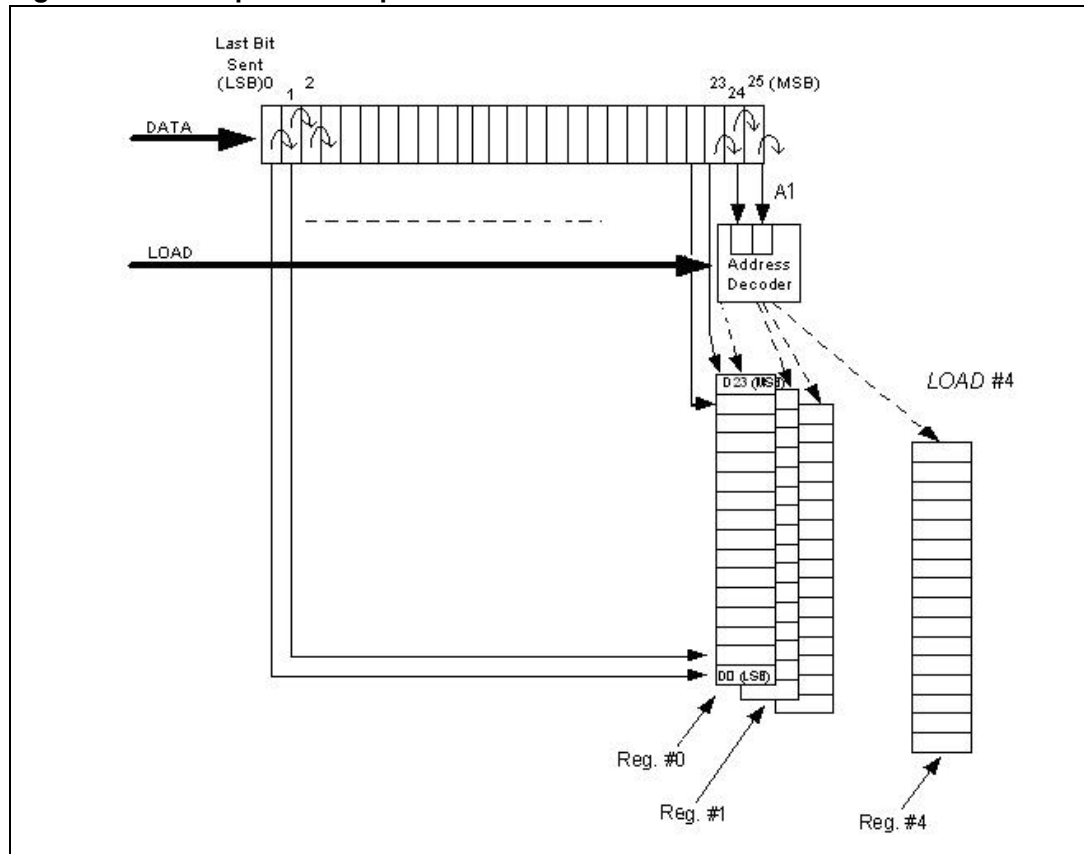

Table 17. SPI data structure (MSB is sent first)

MSB																										LSB
Address		Data for Register (24 bits)																								
A1	A0	D23	D22	D21	D20	D19	D18	D17	D16	D15	D14	D13	D12	D11	D10	D9	D8	D7	D6	D5	D4	D3	D2	D1	D0	

Table 18. Address decoder and outputs

Address		Outputs			
A1	A0	DATABITS D23-D0	No	Name	Function
0	0	24	0	ST1	Reference divider, VCO amplitude, VCO Calibration, Charge Pump current, Prescaler Modulus
0	1	24	1	ST2	Functional modes, VCO dividers
1	0	24	2	ST3	Reserved
1	1	24	3	ST4	Reserved

## 6.2 Timing specification

Figure 23. SPI Timing specification

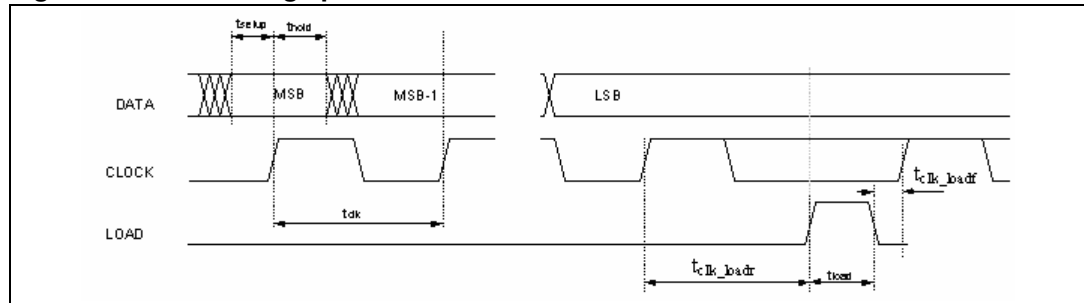

Table 19. SPI Timing specification

Parameter	Description	Min.	Typ.	Max.	Unit
tsetup	DATA to CLOCK setup time	0.8			ns
thold	DATA to clock hold time	0.2			ns
tclk	CLOCK cycle period	10			ns
tload	LOAD pulse width	3			ns
tclk_loadr	CLOCK to LOAD rising edge	2			ns
tclk_loadf	CLOCK to LOAD falling edge	0.5			ns

## 6.3 Bits table

Table 20. Bits

Serial Interface Address = 00h		Register name = ST1
Bit	Name	Description
[23]	R9	REFERENCE CLOCK DIVIDER RATIO
[22]	R8	
[21]	R7	
[20]	R6	
[19]	R5	
[18]	R4	
[17]	R3	
[16]	R2	
[15]	R1	
[14]	R0	
[13]	PLL_A1	VCO Amplitude Control
[12]	PLL_A0	
[11]	CPSEL2	Charge Pump output current Control
[10]	CPSEL1	
[9]	CPSEL0	
[8]	PSC_SEL	Prescaler Modulus select ('0' for P=16, '1' for P=19)
[7]	INITCAL	test purpose only; must be set to '0'
[6]	SERCAL	Enable VCO calibration (see paragraph xxx)
[5]	SELEXTCAL	test purpose only; must be set to '0'
[4]	CAL4	test purpose only; must be set to '0'
[3]	CAL3	
[2]	CAL2	
[1]	CAL1	
[0]	CAL0	

**Table 20. Bits (continued)**

Serial Interface Address = 00h		Register name = ST1	
Bit	Name	Description	
[23]	PD6	DEVICE FUNCTIONAL MODES 0. Power down 1. Enable VCO A, output frequency divided by 2 2. Enable VCO B, output frequency divided by 2 3. Enable external VCO, output frequency divided by 2 4. Enable VCO A, output frequency divided by 4 5. Enable VCO B, output frequency divided by 4 6. Enable external VCO, output frequency divided by 4 7. Enable VCO A, direct output 8. Enable VCO B, direct output 9. Enable external VCO, direct output	
[22]	PD5		
[21]	PD4		
[20]	PD3		
[19]	PD2		
[18]	PD1		
[17]	PD0		
[16]	B11		B Counter Bits
[15]	B10		
[14]	B9		
[13]	B8		
[12]	B7		
[11]	B6		
[10]	B5		
[9]	B4		
[8]	B3		
[7]	B2		
[6]	B1		
[5]	B0	A Counter Bits	
[4]	A4		
[3]	A3		
[2]	A2		
[1]	A1		
[0]	A0		

The LO output frequency is programmed by setting the proper value for A,B and R according to the following formula:

$$F_{OUT} = D_R \cdot (B \cdot P + A) \cdot \frac{F_{REF\_CLK}}{R}$$

where  $D_R$  equals  $\begin{cases} 1 & \text{for Direct Output} \\ 0.5 & \text{for Output Divided by 2} \\ 0.25 & \text{for Output Divided by 4} \end{cases}$

and P is the selected Prescaler Modulus

## 6.4 VCO calibration procedure

The calibration of the VCO center frequency is activated by a '0' to '1' transition of the SERCAL bit (ST1 Register bit[6]).

In order to program properly the device, ensuring the VCO calibration, the following procedure is required before every channel change:

- a) Program the ST1 Register with the desired settings (R counter, VCO amplitude, Charge Pump, Prescaler Modulus) and SERCAL bit set to '0'
- b) Program the ST2 Register with the desired settings (Functional mode, B and A counters)
- c) Program the ST1 Register with the desired settings (R counter, VCO amplitude, Charge Pump, Prescaler Modulus) and SERCAL bit set to '1'

The maximum allowed PFD frequency ( $f_{\text{PFD}}$ ) to perform the calibration process is 1 MHz; if the desired  $f_{\text{PFD}}$  is higher than 1MHz the following steps are needed:

- Perform all the steps of the calibration procedure programming the desired VCO frequency with a proper setting of R, B and A counter so that  $f_{\text{PFD}}$  is  $\leq 1\text{MHz}$ .
- Program the device with the proper setting for the desired VCO and PFD frequencies according to the above step a) and b) only.

## 7 Application information

The STW81101 features three different alternatively selectable bands: direct output (3.3 to 4.4GHz), divided by 2 (1.65 to 2.2GHz) and divided by 4 (850 to 1100MHz). In order to achieve a suitable power level, a good matching network is needed to adapt the output stage to a 50Ω load. Moreover, since most of commercial RF components have single ended input and output terminations, a differential to single ended conversion could be required.

Below different matching configurations for the three bands are suggested as a guideline for the design of own application board.

The user can find in the Evaluation Kit the ADS Design for each matching configuration suggested in this section. The name of the corresponding ADS Design is reported below each figure.

### 7.1 Direct Output

If a differential to single conversion is not needed it is possible to match the output buffer of the STW81101 in the simple way shown in [Figure 24](#).

**Figure 24. Differential/single ended output network in the 3.3 - 4.4GHz range (MATCH\_LC\_LUMP\_4G\_DIFF.dsn)**

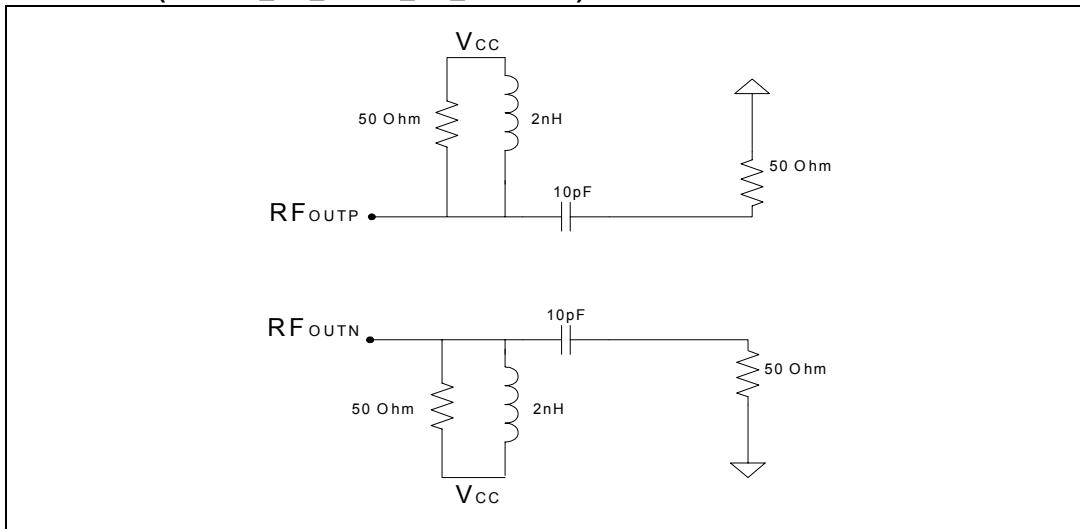

Since most of discrete components for microwave applications are single ended, the user can easily use one of the two outputs and terminate the other one to 50Ω with a 3dB power loss.

Alternatively it is possible to combine the 2 outputs in different ways. A first topology for the direct output (3.3GHz to 4.4GHz) is suggested in [Figure 25](#). It basically consists of a simple LC balun and a matching network to adapt the output to a 50Ω load. The two LC networks shift output signal phase of -90° and +90° thus combining the 2 outputs. This topology, designed for a center frequency of 4GHz, is intrinsically narrow band, since the LC balun is tuned at a single frequency. If the application requires a different sub-band, the LC combiner could be easily adjusted to be tuned at the frequency of interest.

**Figure 25. LC lumped balun and matching network (MATCH\_LC\_LUMP\_4G.dsn)**

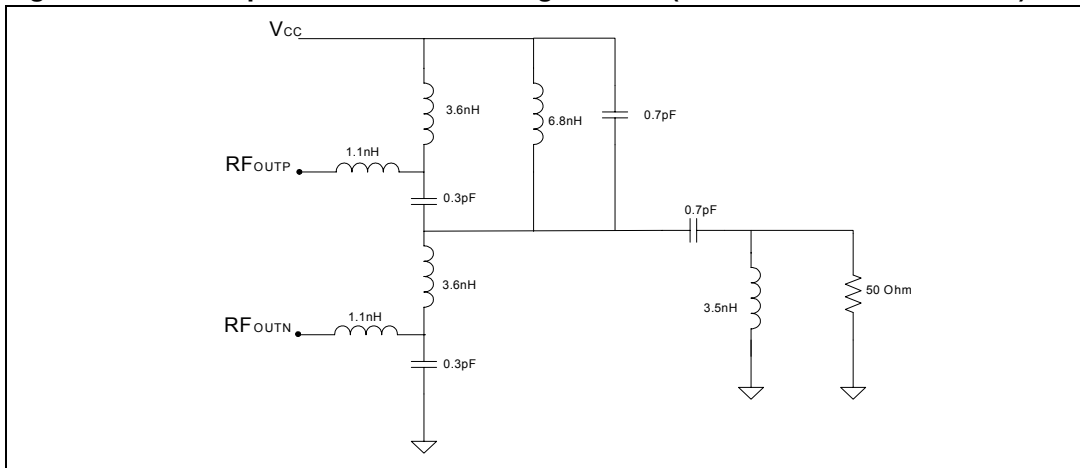

The 6.8nH shunt inductor works as a DC feed for one of the open collector terminal as well as a matching element along with the other components. The 1.1nH series inductors are used to resonate the parasitic capacitance of the chip.

For an optimum output matching it is recommended to use 0402 Murata or AVX capacitors and 0403 or 0604 HQ Coilcraft inductors. It is also advisable to use short interconnection paths to minimize losses and undesired impedance shift.

An alternative topology, which allows for a more broadband matching and balanced to unbalanced conversion, is shown in [Figure 26](#).

**Figure 26. Microstrip line and lumped matching network (MATCH\_4G\_HYBRID.dsn)**

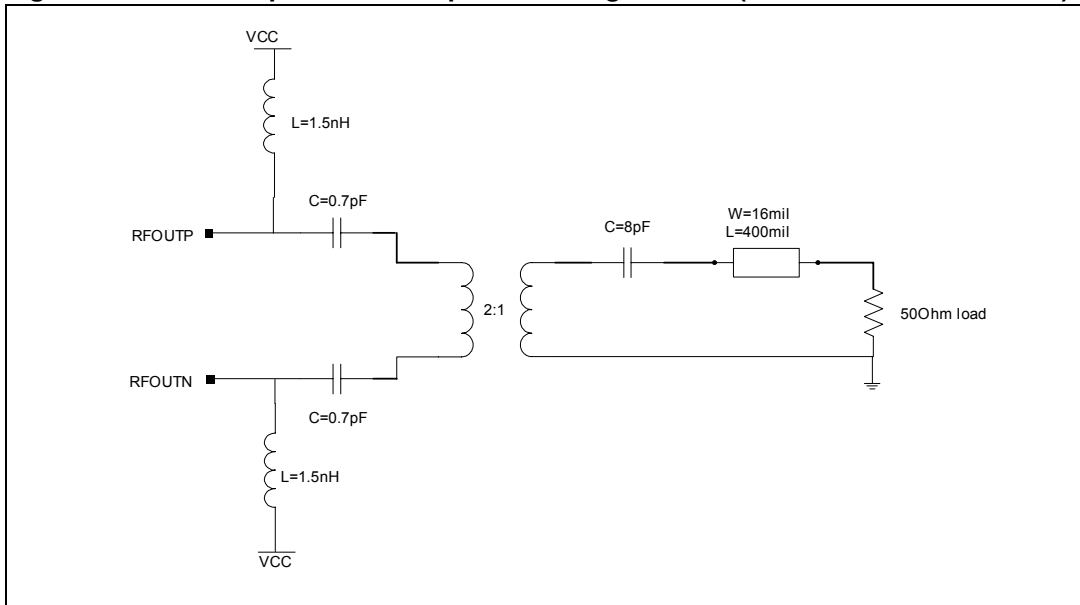

Those results have been achieved on an FR4 substrate with a thickness of 350um.

By using this topology the STW81101 is capable to deliver an almost flat power to a 50Ω load with a return loss greater than 10dB over the whole frequency band (3.3 to 4.4GHz).

For the differential to single conversion the 50 to 100Ω Johanson balun is recommended (3700BL15B100).

## 7.2 Divided by 2 Output

If the user's application does not require a balanced to unbalanced conversion, the output matching reduces to the simple circuit shown below (*Figure 27*).

This solution can be easily used to provide one single ended output just terminating the other output at 50Ω with a 3dB power loss.

**Figure 27. Differential/single ended output network in the 1.65 - 2.2GHz range (MATCH\_LC\_LUMP\_2G\_DIFF.dsn)**

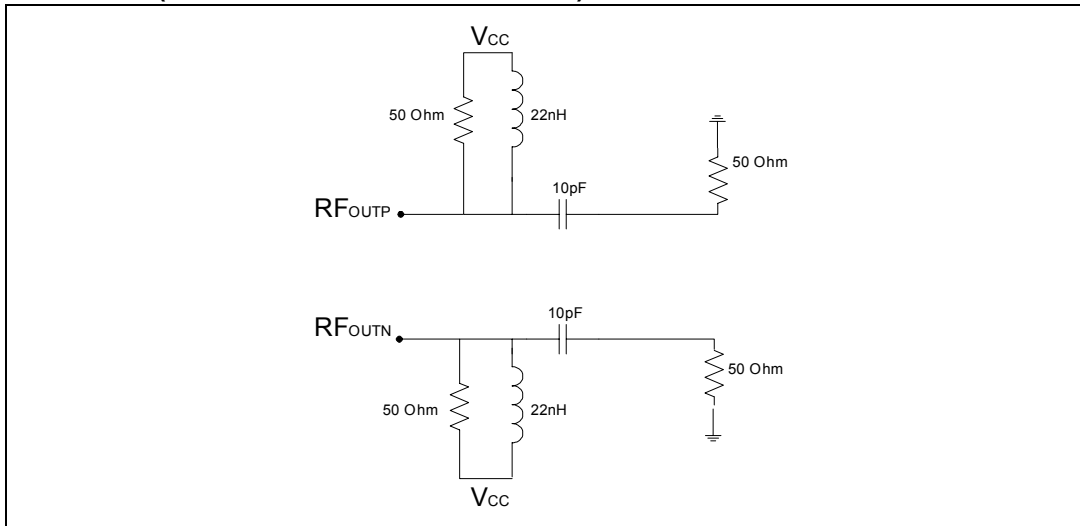

A first solution to combine the differential outputs is the lumped LC type balun tuned in the 2GHz band (*Figure 28*).

**Figure 28. LC lumped balun for divided by 2 output (MATCH\_LC\_LUMP\_2G.dsn)**

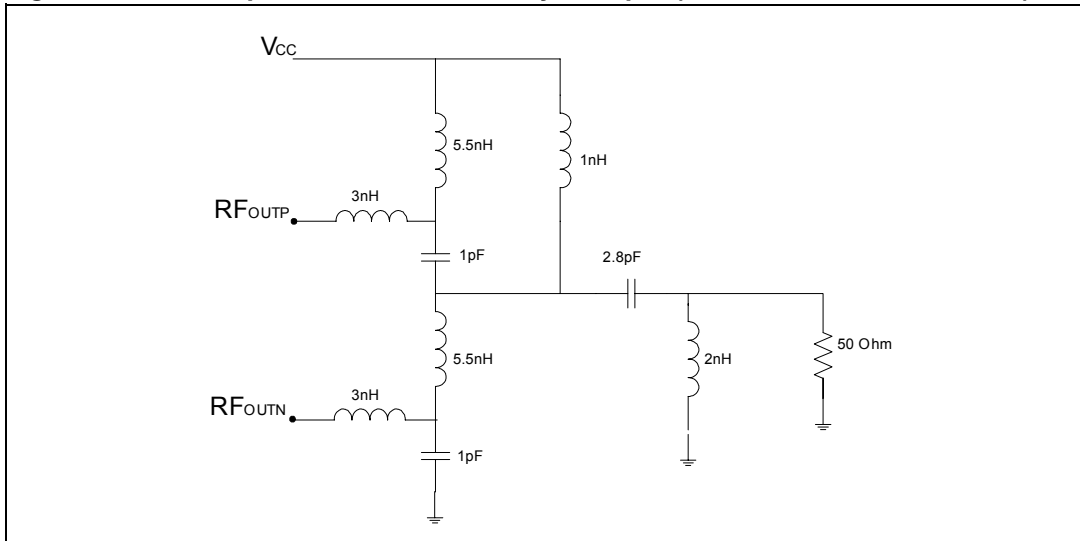

The same recommendation for the SMD components applies also for the divided by 2 output.

Another topology suitable to combine the two outputs for the divided by 2 frequencies is represented in *Figure 29*.

**Figure 29. Lumped output matching for divided by 2 output (MATCH\_LC\_BAL\_2G.dsn)**

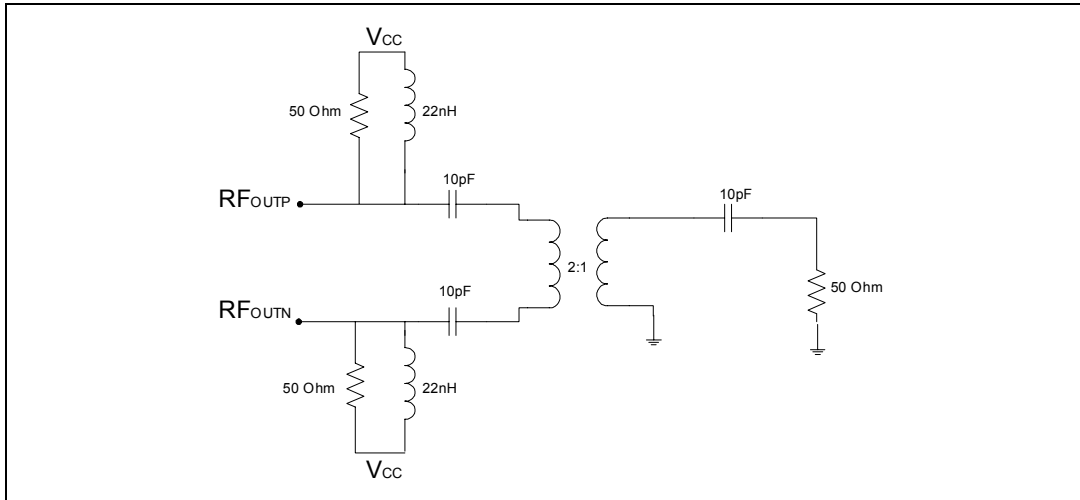

For the differential to single conversion the 50 to 100Ω Johanson balun (1600BL15B100) is recommended.

### 7.3 Divided by 4 Output

The same topology, components values and considerations of [Figure 27](#), applies also for the divided by 4 output (MATCH\_LC\_LUMP\_1G\_DIFF.dsn).

As for the previous sections, a solution to combine the differential outputs is the lumped LC type balun tuned in the 1GHz band ([Figure 30](#)).

**Figure 30. LC lumped balun for the divided by 4 output (MATCH\_LC\_LUMP\_1G.dsn)**

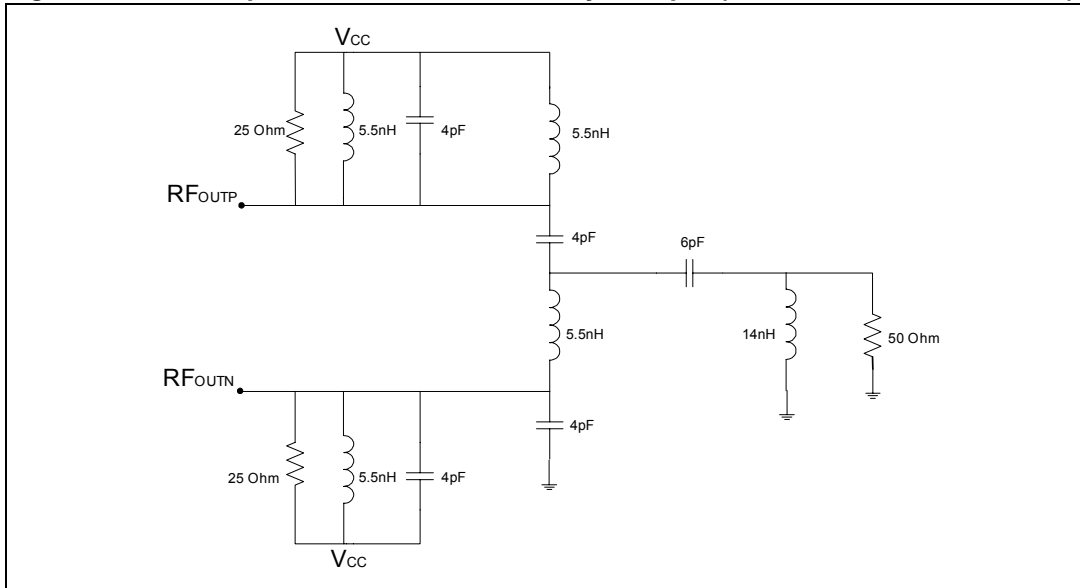

If the user prefers to use an RF balun it is possible to adopt the same topology depicted in [Figure 29](#), just changing the balun and the resistor value ([Figure 31](#)). The suggested balun for the 0.8 - 1.1GHz frequency range is the 1:1 Johanson 900BL15C050.

**Figure 31. Lumped output matching for divided by 4 output (MATCH\_LC\_BAL\_1G.dsn)**

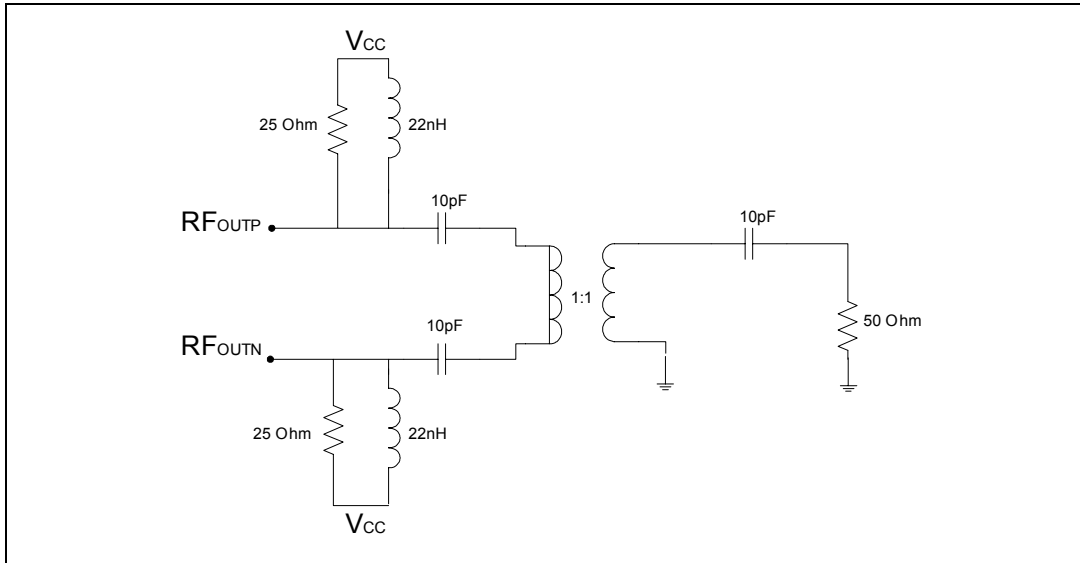

## 7.4 Evaluation Kit

Upon request an Evaluation Kit can be delivered. It includes:

- Evaluation Board
- GUI (Graphical User Interface) to program the device
- Measured S parameters of the RF output
- ADS2005 schematics providing guidelines for application board design
- STWPLLSim software for PLL loop filter design and noise simulation

Three different Evaluation Kits are available, one optimized for 1GHz frequency range, one for 2GHz frequency range and the last one for 4GHz range.

While ordering please specify the following order codes:

**Table 21. Order code of the evaluation kit**

Part Number	Description
STW81101-EVB1G	1GHz frequency range - Divider by 4 output optimized
STW81101-EVB2G	2GHz frequency range - Divider by 2 output optimized
STW81101-EVB4G	4GHz frequency range - Direct output optimized

The three Evaluation Kits differ only regarding the output balun and the choke inductors of the related Evaluation Board; each Evaluation Kit is provided with the needed components (baluns and inductors) in order to easily adapt the output stage to a different frequency range.

# 8 Application diagram

Figure 32. Application diiagram

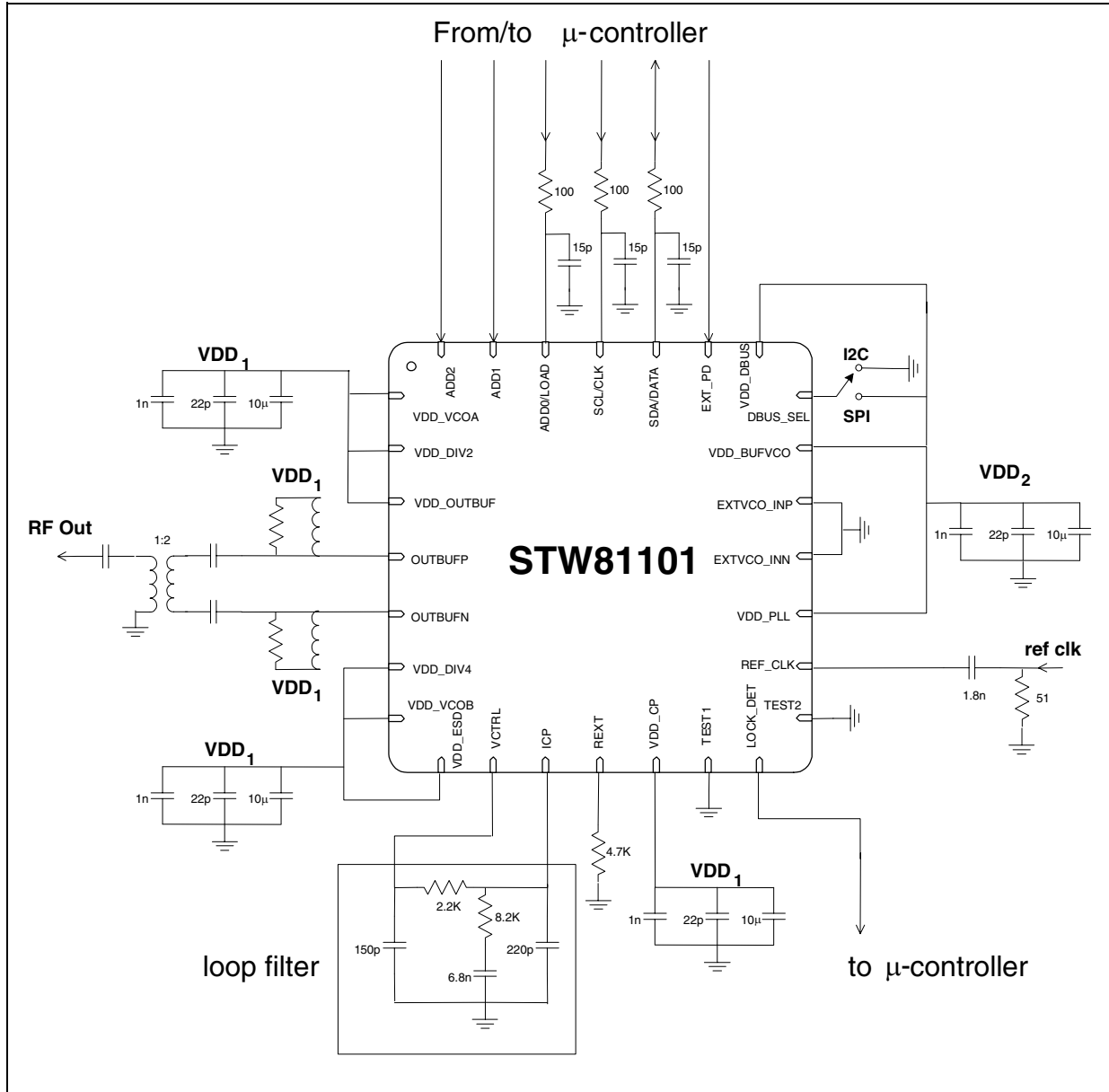

- Note:
- 1 See Application Information (Section 7) for further information on Output Matching topology.
  - 2 EXT\_PD, ADD2, ADD1 (and ADD0 when I<sup>2</sup>C Bus is selected) can be hard wired directly on the board.
  - 3 Loop Filter values are for  $f_{PF D} = 400\text{KHz}$  and  $I_{CP} = 4\text{mA}$ .

# 9 Package information

In order to meet environmental requirements, ST offers these devices in ECOPACK® packages. These packages have a Lead-free second level interconnect. The category of second Level Interconnect is marked on the package and on the inner box label, in compliance with JEDEC Standard JESD97. The maximum ratings related to soldering conditions are also marked on the inner box label. ECOPACK is an ST trademark.

ECOPACK specifications are available at: <http://www.st.com>.

**Figure 33. VFQFPN28 Mechanical Data & Package Dimensions**

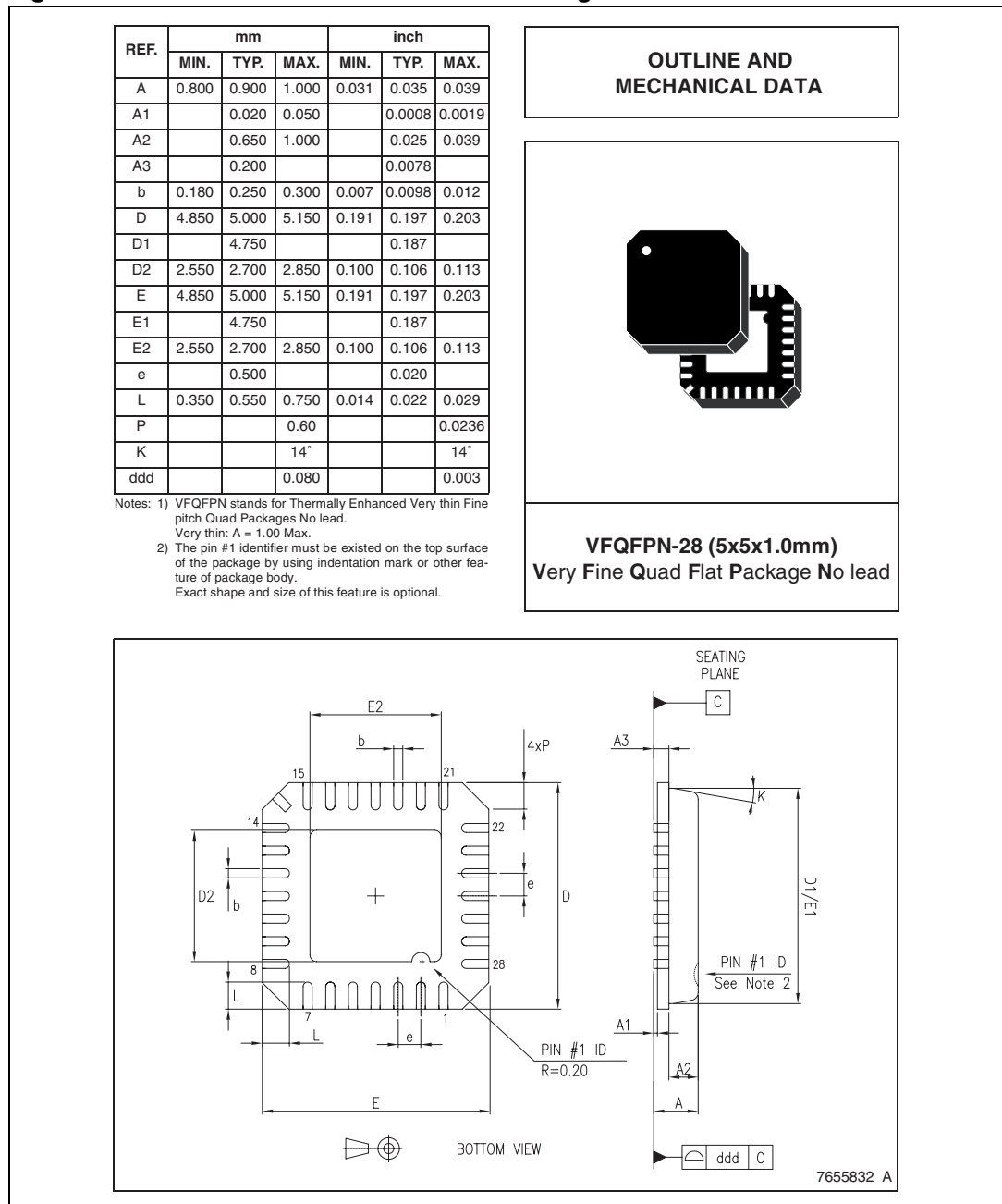

## 10 Revision history

**Table 22. Document revision history**

Date	Revision	Changes
06-Mar-2006	1	Initial release.

**Please Read Carefully:**

Information in this document is provided solely in connection with ST products. STMicroelectronics NV and its subsidiaries ("ST") reserve the right to make changes, corrections, modifications or improvements, to this document, and the products and services described herein at any time, without notice.

All ST products are sold pursuant to ST's terms and conditions of sale.

Purchasers are solely responsible for the choice, selection and use of the ST products and services described herein, and ST assumes no liability whatsoever relating to the choice, selection or use of the ST products and services described herein.

No license, express or implied, by estoppel or otherwise, to any intellectual property rights is granted under this document. If any part of this document refers to any third party products or services it shall not be deemed a license grant by ST for the use of such third party products or services, or any intellectual property contained therein or considered as a warranty covering the use in any manner whatsoever of such third party products or services or any intellectual property contained therein.

**UNLESS OTHERWISE SET FORTH IN ST'S TERMS AND CONDITIONS OF SALE ST DISCLAIMS ANY EXPRESS OR IMPLIED WARRANTY WITH RESPECT TO THE USE AND/OR SALE OF ST PRODUCTS INCLUDING WITHOUT LIMITATION IMPLIED WARRANTIES OF MERCHANTABILITY, FITNESS FOR A PARTICULAR PURPOSE (AND THEIR EQUIVALENTS UNDER THE LAWS OF ANY JURISDICTION), OR INFRINGEMENT OF ANY PATENT, COPYRIGHT OR OTHER INTELLECTUAL PROPERTY RIGHT.**

**UNLESS EXPRESSLY APPROVED IN WRITING BY AN AUTHORIZED REPRESENTATIVE OF ST, ST PRODUCTS ARE NOT DESIGNED, AUTHORIZED OR WARRANTED FOR USE IN MILITARY, AIR CRAFT, SPACE, LIFE SAVING, OR LIFE SUSTAINING APPLICATIONS, NOR IN PRODUCTS OR SYSTEMS, WHERE FAILURE OR MALFUNCTION MAY RESULT IN PERSONAL INJURY, DEATH, OR SEVERE PROPERTY OR ENVIRONMENTAL DAMAGE.**

Resale of ST products with provisions different from the statements and/or technical features set forth in this document shall immediately void any warranty granted by ST for the ST product or service described herein and shall not create or extend in any manner whatsoever, any liability of ST.

ST and the ST logo are trademarks or registered trademarks of ST in various countries.

Information in this document supersedes and replaces all information previously supplied.

The ST logo is a registered trademark of STMicroelectronics. All other names are the property of their respective owners.

© 2006 STMicroelectronics - All rights reserved

STMicroelectronics group of companies

Australia - Belgium - Brazil - Canada - China - Czech Republic - Finland - France - Germany - Hong Kong - India - Israel - Italy - Japan - Malaysia - Malta - Morocco - Singapore - Spain - Sweden - Switzerland - United Kingdom - United States of America

[www.st.com](http://www.st.com)