

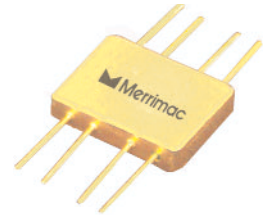

QHF-2A-200 SQ 90° QUADRATURE HYBRID

REV: 001, 03/13/02

- SPACE QUALIFIED
- 190 - 210 MHz, 10% BANDWIDTH
- FLATPACK



TECHNICAL DESCRIPTION / APPLICATION

SERIES 03

The QHF-2A-200 SQ 90° quadrature hybrid covers a frequency range of 190 - 210 MHz using a special lumped element design to reduce the size while maintaining high performance. This device has been designed in accordance with Merrimac document CENG-0001, "Standard Design Requirements for Space Qualified Devices".

GENERAL SPECIFICATIONS

MODEL NUMBER	FREQUENCY RANGE MHz	ISOLATION (dB)		INSERTION LOSS dB		AMPLITUDE BALANCE dB		PHASE BALANCE		VSWR INPUT/ OUTPUT	
		MIN.	TYP.	MAX.	TYP.	MAX.	TYP.	MAX.	TYP.	MAX.	TYP.
QHF-2A-200 SQ	190 - 210	23	27	0.3	0.2	0.75	0.5	±2°	1°	1.3:1	1.2:1
INPUT POWER MAX	COUPLING NOM.	IMPEDANCE NOM.		WEIGHT MAX.		OPERATING TEMPERATURE					
1 W	3.0 dB	50 OHM		2.8 g		-55° to +85 ° C					

PACKAGE OUTLINE

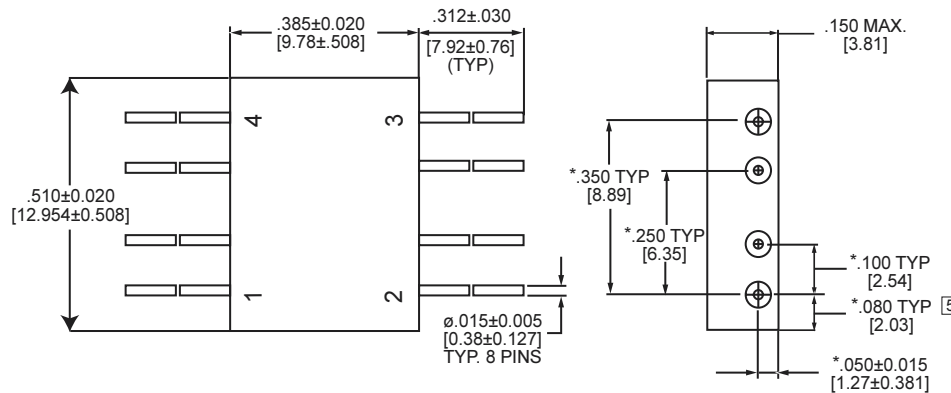

NOTES:

1. TOLERANCE ON 3 PLACE DECIMALS ±.010 [.25mm] EXCEPT AS NOTED.
2. MAX. IS LARGEST DIMENSION ALLOWED.
3. DIMENSIONS = INCHES [mm]
4. METRIC EQUIVALENTS ARE TO THE NEAREST .01mm.
5. ALL LEADS TO BE WITHIN ± .010 [.25mm] OF EACH OTHER AT THIS DIMENSION.
6. DIMENSIONS MARKED WITH * APPLY ONLY AT BODY.
7. ALL UNMARKED PINS ARE CASE GROUND.

Phasing Diagram A

	1	2	3	4
1		0°	-90°	Isolation
2	0°		Isolation	-90°
3	-90°	Isolation		0°
4	Isolation	-90°	0°	