

# FPM-3151G

## 15" XGA Industrial Monitor with Resistive Touchscreen, Direct-VGA, DVI Ports, and Wide Operating Temperature



### Features

- 15" XGA TFT LED LCD with 50,000 backlight life time
- Robust anodized coated aluminum front bezel and stainless steel rear cover
- Supports wide operating temperatures
- Increase reliability by enhanced 5-wire resistive touch sensor
- Anti-glare screen with tempered glass and IP65 certified front panel
- Full enclosure ground isolation protection
- Supports VGA/DVI input, dual touch interfaces and two power inputs
- Front lockable OSD membrane keys with user-defined brightness setting
- Front panel is IP65 compliant
- Supports panel, VESA, wall and desktop stand mounting

### Introduction

The FPM-3151G is a particularly rugged and reliable 15" XGA wide temperature industrial monitor for a variety of industry applications. Equipped with a hard anodized coating, stainless steel chassis, and -20 to 60°C operating temperature, it can satisfy demands in a wide range of harsh industrial applications. This model also features enhanced 5-wire resistive touch and system ground isolation protection to enhance the reliability. FPM-3151G also provides lockable OSD keys on the front panel with two user-defined contrast/brightness settings.

### Specifications

#### General

- **Button Controls** OSD control pad on front panel with lockable function  
Two user-defined contrast/brightness settings
- **Certification** CE, FCC Class A, BSMI, CCC, UL, Energy Star
- **Dimensions (W x H x D)** 422 x 310 x 70 mm (16.61" x 12.2" x 2.76")
- **Enclosure** Front panel: Aluminum with hard anodizing coating  
Rear cover: Stainless steel  
Ground Isolation Protection
- **Mounting** Panel, wall, desktop, VESA arm, or 19" rackmount with optional mounting kit
- **Power Input** Phoenix Jack: 24 V<sub>DC</sub> input  
DC Jack: external 57 W power adapter, with 100 ~ 240 V<sub>AC</sub> input and 12 V<sub>DC</sub> @ 4.75 A output
- **Power Consumption** 12W
- **Video Port** VGA & DVI-D Port
- **Weight (Net)** 7.73 kg (17.04 lbs)

#### LCD Display

- **Display Type** XGA TFT LCD
- **Backlight Type** LED
- **Display Size** 15"
- **Max. Resolution** 1024 x 768
- **Max. Color** 16.2M (RGB 8-bit)
- **Viewing Angle (H/V°)** 160/140
- **Luminance (cd/m<sup>2</sup>)** 350
- **Backlight Life (hrs)** 50,000
- **Contrast Ratio** 700:1

#### Touchscreen (Optional)

- **Driver** Penmount 6000
- **Type** 5-wire resistive with enhanced ITO film
- **Interface** USB & RS-232 (Combo)
- **Lifespan** 36 million with a silicone rubber R8 finger, writing rate is by 250g at 2 times/s
- **Light Transmission** > 80%
- **OS Support** Windows XP, Vista, 7, 8, XPe, CE and Linu x
- **Power Consumption** +5 V @ 100 mA
- **Touch Resolution** Linearity

#### Environment

- **Operation Temperature** -20 ~ 60°C (-4 ~ 140°F)
- **Storage Temperature** -30 ~ 80°C (-22 ~ 176°F)
- **Humidity (Storage)** 10 ~ 95% non-condensing
- **Waterproof** Front panel is IP65 compliant
- **Shock** 11ms, 10G (Non Operating, Half Sine Wave)
- **Vibration** 5 ~ 500 Hz, 1 Grms (Operating, Random)

### Ordering Information

- **FPM-3151G-X0AE** 15" XGA Ind. Monitor with Wide Temp
- **FPM-3151G-R3AE** 15" XGA Ind. Monitor w/ Wide Temp, Resistive TS
- **FPM-3151SR-R3AE** 15" XGA Ind. Monitor w/ Sunlight Readable Display

## Dimensions

Unit: mm [inch]

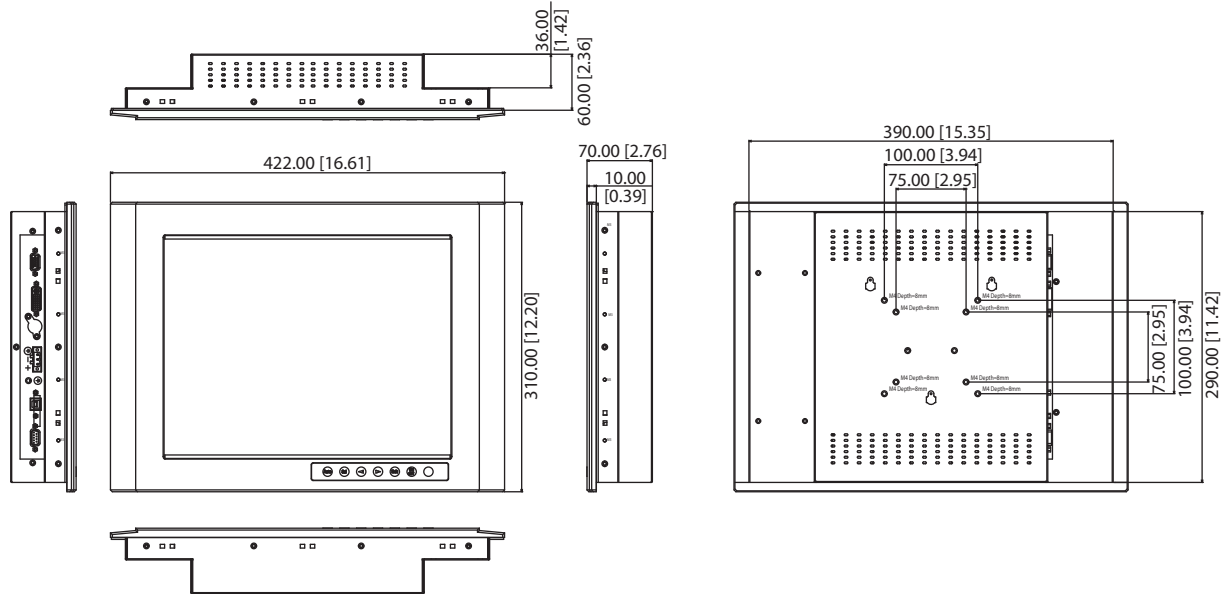

Panel Cut-out Dimensions: 396 x 296 mm (15.59" x 11.65")

## Accessories

- **FPM-3151G-RMKE** Mounting kit for 19" industrial rack
- **1702002600** Power Cable US Plug 1.8 M
- **1702002605** Power Cable EU Plug 1.8 M
- **1702031801** Power Cable UK Plug 1.8 M
- **1700000596** Power Cable China/Australia Plug 1.8 M
- **FPM-2120G-SMKE** FPM-2120G/2150G/2170G Stand Kit

## Rack Mount (FPM-3151G-RMKE)



## I/O View

