

ITS 31030 (GR) and ITS 41030 (GR) Rear Panel Mount Square Flange Receptacle Assembly with Rotating Clamp Nut for Heat-Shrink Tubing

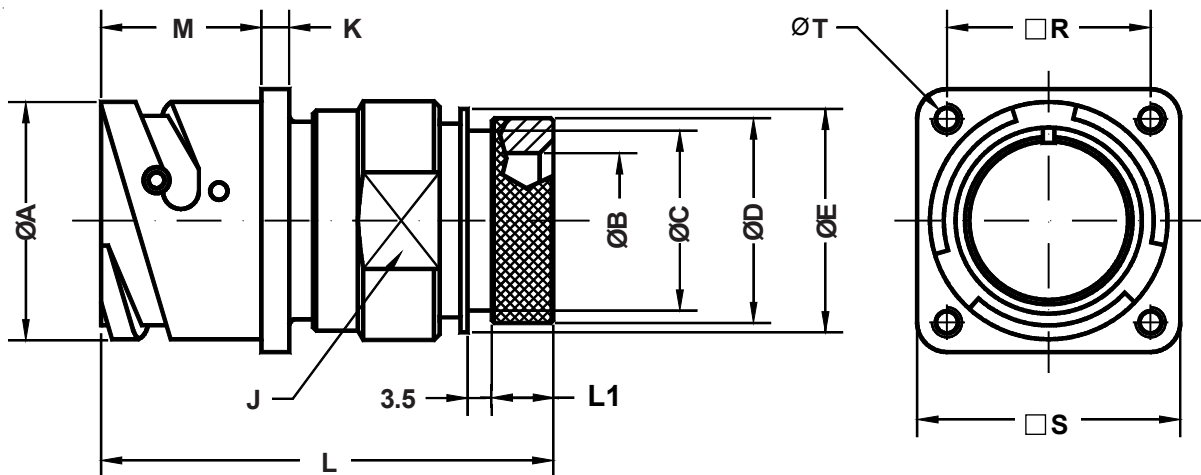
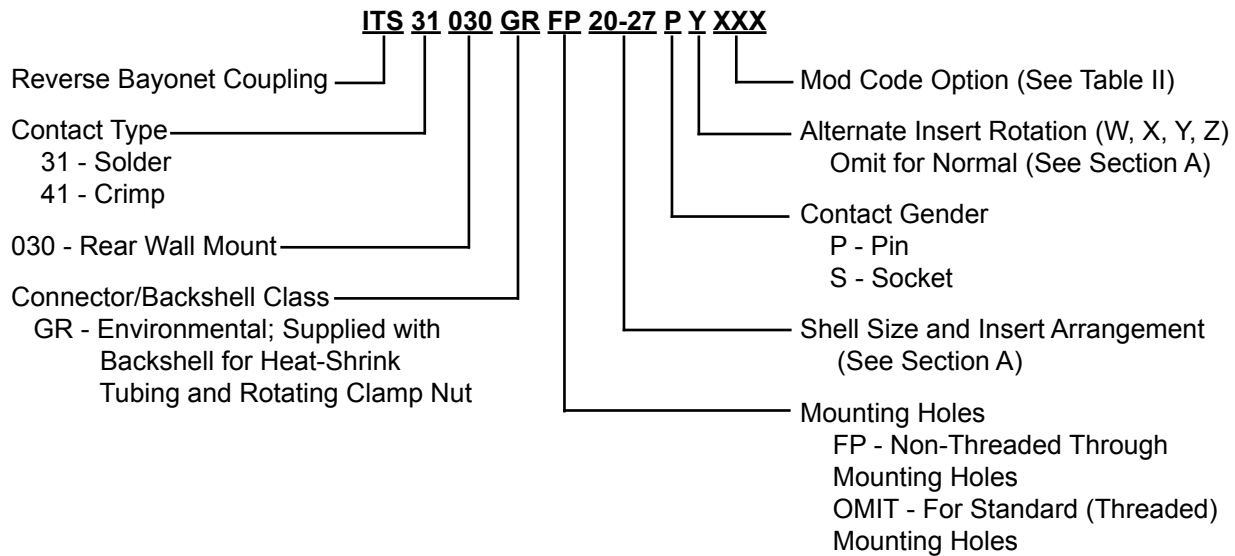

Application Notes:

1. Rear panel mount square flange receptacle with backshell for heat-shrink tubing. Rotating coupling nut supplied. Threaded mounting holes. Optional non-threaded mounting holes available.
2. Environmental class "GR" (environmental)—Wire sealing grommet supplied.
3. Standard materials configuration consists of aluminum alloy. For platings, see TABLE II finish options.
4. Standard contact material consists of copper alloy with silver plating or gold plating.
5. A broad range of additional connector accessories are available. See our website and/or contact the factory for complete information.
6. Standard insert material is synthetic rubber. Add "FR" prefix to front of part number to specify fire resistant inserts.

ITS 31030 (GR) and ITS 41030 (GR)
Rear Panel Mount Square Flange Receptacle Assembly
with Rotating Clamp Nut for Heat-Shrink Tubing



TABLE I: DIMENSIONS

Shell Size	ØA +0 -0.1	ØB min.	ØC ±0.1	ØD ±0.2	ØE ±0.1	J key	K ±0.2	L Max.	L1 ±0.1	M +0.2 -0	R ±0.1	S +0.2	T Thread
10 SL	18.2	8.6	13.0	15.5	17.0	20	2.8	57.7	8.2	18.5	18.25	25.4	M4
14 S	24.5	10.7	16.5	19.1	20.1	23	3.3	58.4	8.2	18.5	23.00	30.4	M4
16 S	27.2	14.0	24.9	23.9	23.5	26	3.3	58.4	8.0	18.5	24.60	32.5	M4
16	27.2	14.0	24.9	23.9	23.5	26	3.3	70.8	8.0	23.2	24.60	32.5	M4
18	30.7	17.5	21.7	23.9	26.5	28	4.0	70.8	8.0	23.2	27.00	35.0	M4
20	34.0	18.8	26.2	29.6	30.2	32	4.0	71.1	8.9	23.2	29.40	38.0	M4
22	37.3	21.0	26.2	29.6	33.6	36	4.0	71.1	9.2	23.2	31.75	41.0	M4
24	40.9	25.4	34.0	37.8	36.1	39	4.0	70.7	9.5	23.2	34.90	44.5	M4
28	46.7	28.4	34.3	37.8	41.4	46	4.0	71.2	9.2	24.4	39.70	50.9	M5
32	53.4	34.0	43.6	47.8	48.6	52	4.0	78.8	11.7	24.2	44.45	57.0	M5
36	59.6	40.5	43.6	47.8	54.0	58	4.0	88.8	11.5	24.2	49.20	63.5	M5
40	65.5	49.0	52.6	57.8	61.0	65	4.0	88.8	11.5	24.4	55.55	69.9	M5

B

TABLE II: MODIFICATION CODES

CONTACT OPTIONS	
Sym	Description
B0	Connector Less Contacts
B1	Connector with Gold Plated Contacts
Omit for standard version (Silver plated)	
FINISH OPTIONS	
Sym	Description and RoHS compliant (*)
F2	Bright Nickel Plating (*)
F6	Black Electrodeposited Paint (*)
F7	Black Zn-Co Plating (*)
F8	Olive Drab Zn-Co Plating
F11	Electroless Nickel (*)
Omit for standard version (Cadmium Olive Drab Finish)	