

Hybrid IC Isolation Amplifiers 20 Series

ISOLATION AMPLIFIER

(4-port isolation)

Functions & Features

- Being used for printed wiring board installation
- Isolating between input, output and output 2
- Dielectric strength 1500 V AC between input, output and output 2
- Power 18 V DC

Typical Applications

- Isolating the field and input or output circuit of microprocessor to reduce noise from field
- Available for manufacturers of small-lot products to omit the development of isolation circuit

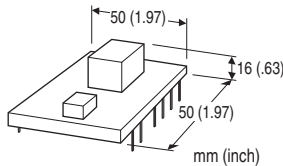

MODEL: 20VS1E-5W5W-U2

ORDERING INFORMATION

- Code number: 20VS1E-5W5W-U2

INPUT

Voltage

5W: -5 - +5 V DC (Input resistance 1 MΩ min.)

OUTPUT

Voltage

5W: -5 - +5 V DC (Load resistance 2 kΩ)

POWER INPUT

DC Power

U2: 18 V DC

GENERAL SPECIFICATIONS

Construction: Hybrid IC

PWB coating: Silicone

Isolation: Input or A output to output or B output to C output to power

INPUT SPECIFICATIONS

■ DC Voltage

Input : -5 - +5 V DC

Input resistance: $\geq 1 \text{ M}\Omega$ (10 kΩ in power failure)

Overload input voltage: 30 V DC continuous

Input offset voltage: $\pm 10 \text{ mV}$

OUTPUT SPECIFICATIONS

■ DC Voltage: -5 - +5 V DC

Load resistance: $\geq 2 \text{ k}\Omega$

Output impedance: $\leq 1 \Omega$

A, B, C OUTPUT VOLTAGE

For 18 V power

Load current:

• A output: $\pm 15 \text{ V } 5 \text{ mA}$ (4.7μF in connection)

• B output: $\pm 15 \text{ V } 15 \text{ mA}$ (10μF in connection)

• C output: $25 \text{ V } 30 \text{ mA}$ (4.7μF in connection)

Output voltage setting accuracy:

• $\pm 15 \%$ (A, B) (25°C @ 18 V DC power; with total load)

• $\pm 15 \%$ (C) (25°C @ 18 V DC power; with total load)

INSTALLATION

Power input

• DC: Rating $\pm 5 \%$; approx. 40 mA (with no load); ripple 2 %p-p max.

Operating temperature: 0 to 60°C (32 to 140°F)

Operating humidity: 30 to 90 %RH (non-condensing)

Mounting: Soldering to the printed wiring board

Weight: 30 g (1.1 oz)

PERFORMANCE in percentage of span

Unless otherwise specified, $G = 1$.

Linearity: $\pm 0.05 \%$

Temp. coefficient: 80 ppm/°C TYP.

Frequency characteristics: Approx. 200 Hz (-3 dB minimum)

Response time: $\leq 2 \text{ ms}$ (0 - 90 %)

Conversion gain: $\times 1 \pm 2 \%$

Line voltage effect: $\pm 0.05 \%$ over voltage range

Insulation resistance: $\geq 100 \text{ M}\Omega$ with 500 V DC

Dielectric strength: 1500 V AC @ 1 minute (input or A output to output or B output to C output to power)

EXTERNAL DIMENSIONS & TERMINAL ASSIGNMENTS unit: mm

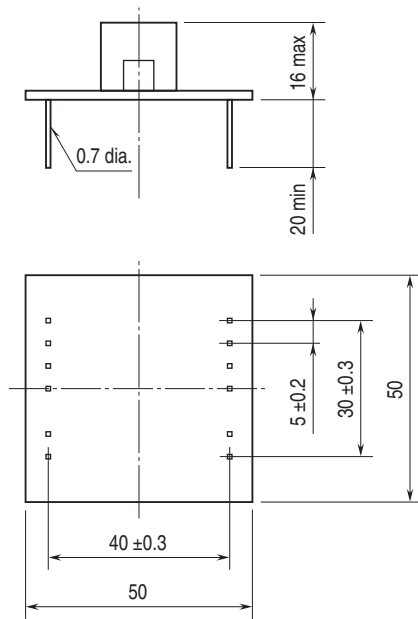

PIN ASSIGNMENT

INPUT SIGNAL (+)	1	8	OUTPUT SIGNAL (+)
A OUTPUT COM1 (-)	2	9	B OUTPUT COM2 (-)
A OUTPUT +15V	3	10	B OUTPUT +15V
A OUTPUT -15V	4	11	B OUTPUT -15V
POWER SUPPLY (+)	6	13	C OUTPUT +25V
POWER SUPPLY (-)	7	14	C OUTPUT COM3 (-)

(BOTTOM VIEW)

SCHEMATIC CIRCUITRY & CONNECTION DIAGRAM

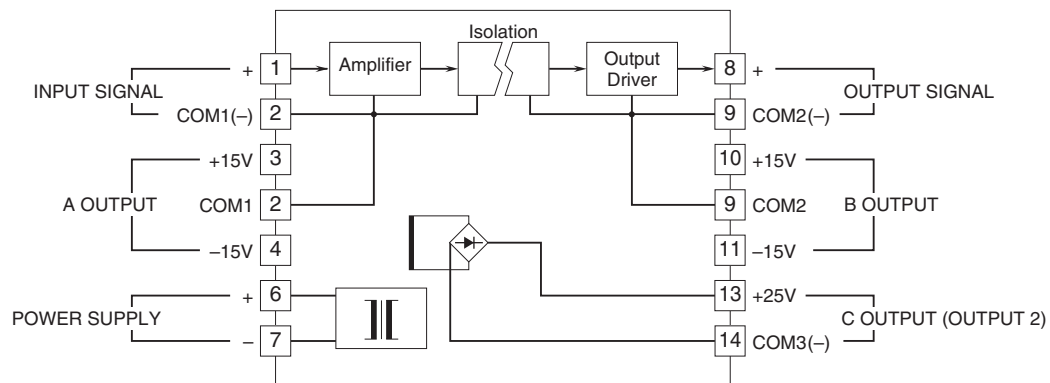

Specifications are subject to change without notice.