

2.1-GHz to 2.7-GHz 1-W Power Amplifier

FEATURES

- 1.5 W P-1 dBm Linear, 30-dB Gain Transmitter
- Operates Over the MMDS, MDS, and WCS Bands (2.1 GHz to 2.7 GHz)
- Two TTL Controlled, 1-bit, 16-dB Gain Steps
- Superior Linearity Over the Entire Gain Range
- PACNT Signal Enables and Disables PA
- Internally Matched 50-Ω Input and Output

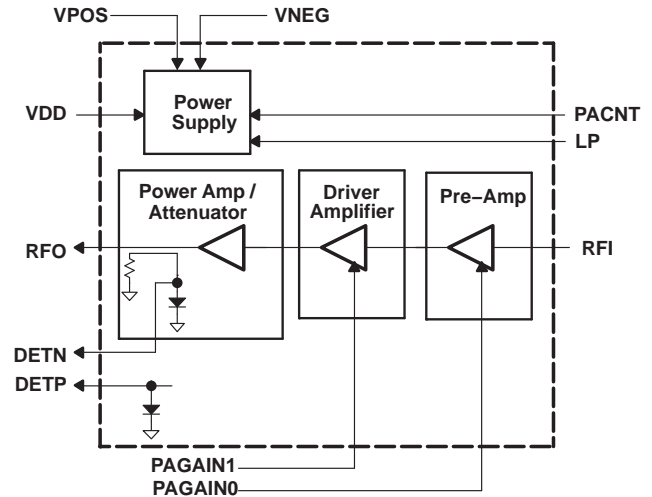

DESCRIPTION

The TRF1123 is a highly integrated linear transmitter power amplifier MMIC. The chip has two 16-dB gain steps that provide a total of 32-dB gain control via 1-bit TTL control signals. The chip also integrates a TTL mute function that turns off the amplifiers for power critical or TDD applications. A temperature compensated detector is included for output power monitor or ALC applications. The chip has a typical P1dB of 31.5 dBm and a third order intercept of 52 dBm.

The TRF1123 is designed to function as a part of Texas Instruments complete 2.5-GHz chip set. The TRF1123 is used as the output power amplifier or a driver amplifier for higher power applications. The linear nature of the transmitter makes it ideal for complex modulations schemes such as high order QAM or OFDM.

KEY SPECIFICATIONS

- $OP_{1dB} = 31.5$ dBm, Typical
- Output IP3 = 52 dBm, Typical
- Gain = 30 dB, Typical
- Gain Flatness Over Transmit Band ± 2.5 dB
- Frequency Range: 2.1 GHz to 2.7 GHz
- ± 0.5 -dB Detected Output voltage vs Temperature

BLOCK DIAGRAM

The detailed block diagram and the pin-out of the ASIC are shown in [Figure 1](#).



Please be aware that an important notice concerning availability, standard warranty, and use in critical applications of Texas Instruments semiconductor products and disclaimers thereto appears at the end of this data sheet.

KEY SPECIFICATIONS (continued)

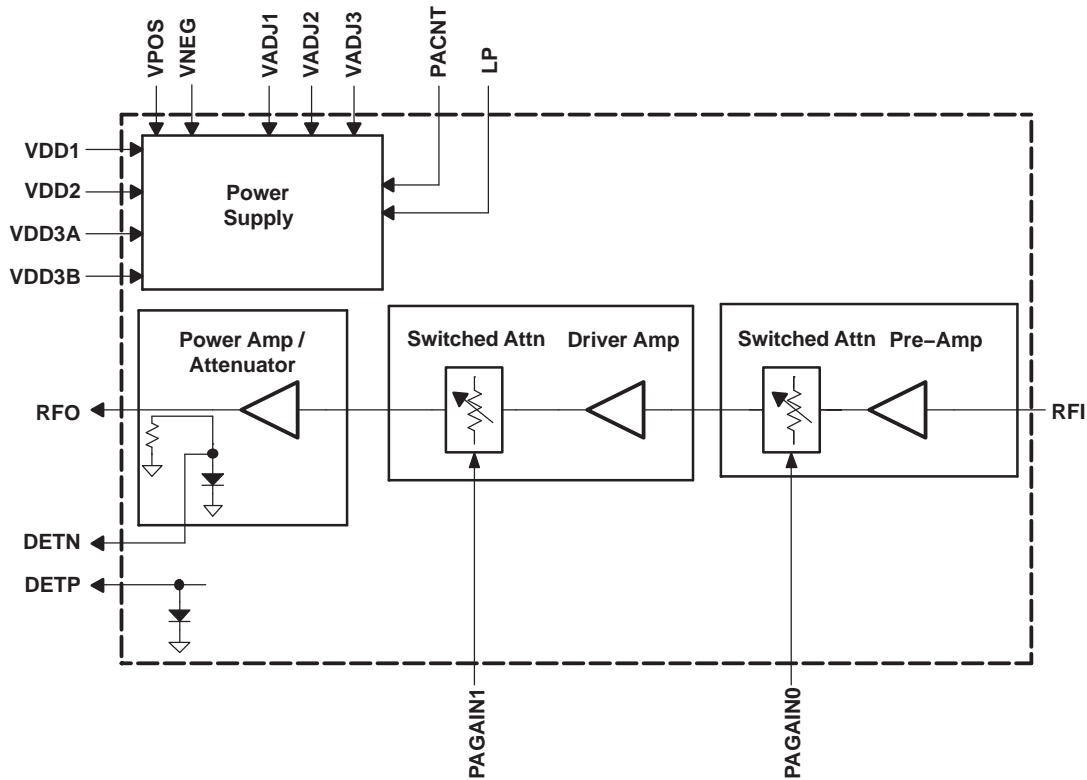

Figure 1. Detailed Block Diagram of TRF1123

ELECTROSTATIC DISCHARGE NOTE

The TRF1223 contain Class 1 devices. The following Electrostatic Discharge (ESD) precautions are recommended:

- Protective outer garments
- Handling in ESD safeguarded work area
- Transporting in ESD shielded containers
- Frequent monitoring and testing all ESD protection equipment
- Treating the TRF1223 as extremely sensitive to ESD

PINOUT TABLE

Table 1. Pinout of TRF1123

PIN #	PIN NAME	I/O	TYPE	DESCRIPTION
1	GND	-	-	Ground
2	GND	-	-	Ground
3	GND	-	-	Ground
4	RFI	I	Analog	RF input to power amplifier, dc blocked internally.
5	GND	-	-	Ground
6	VG1	I/O	Analog	No connection required for normal operation. May be used to adjust FET1 bias. DO NOT GROUND THIS PIN.
7	GND	-	-	Ground

KEY SPECIFICATIONS (continued)
Table 1. Pinout of TRF1123 (continued)

PIN #	PIN NAME	I/O	TYPE	DESCRIPTION
8	VNEG	I	Power	Negative power supply –5 V. Used to set gate voltage. This voltage must be sequenced with VDD. See ⁽¹⁾ .
9	VPOS	I	Power	Positive power supply. Bias is +V. Used to set gate bias and logic input level.
10	PAGAIN0	I	Digital	First 16-dB attenuator gain control. Logic high is high gain; logic low is low gain.
11	VG2	I/O	Analog	No connection required for normal operation. May be used to adjust FET2 bias. DO NOT GROUND THIS PIN.
12	PAGAIN1	I	Digital	Second 16-dB gain control. Logic high is high gain, Logic low is low gain.
13	VG3	I/O		No connection required for normal operation. May be used to adjust FET3 bias. DO NOT GROUND THIS PIN.
14	LP	I	Digital	Low Power Mode: Active high. Low power mode is lower DC and Pout mode.
15	PACNT	I	Digital	Power amplifier enable, high is PA on, logic low is PA off (low current)
16	GND	-	-	Ground
17	VDD3B	I	Power	Stage 3 dc drain supply power. This pin is internally dc connected to pin 24 (VDD3A). Bias must be provided to both pins for optimal performance. The total dc current through these two pins is typically 70% of IDD.
18	GND	-	-	Ground
19	GND	-	-	Ground
20	GND	-	-	Ground
21	RFO	O	Analog	RF output dc block is provided
22	GND	-	-	Ground
23	GND	-	-	Ground
24	VDD3A	I	Power	Stage 3 dc drain supply power. This pin is internally dc connected to pin 17 (VDD3B). Bias must be provided to both pins for optimal performance. The total dc current through these two pins is typically 70% of IDD.
25	GND	-	-	Ground
26	DETP	O	Analog	Detector output, positive. Voltage will be 0.5 V with/without RF output
27	DETN	O	Analog	Detector output, negative. Voltage is 0.5 V with no RF and decreases with increasing RF output power.
28	VDD2	I	Power	Stage 2 dc drain supply power. The dc current through this pin is typically 25% of IDD.
29	GND	-	-	Ground
30	GND	-	-	Ground
31	VDD1	-		Stage 1 dc drain supply power. The dc current through this pin is typically 5% of IDD.
32	GND	-	-	Ground
	Back	-	-	Back of package has metal base that must be grounded for thermal and RF performance.

- (1) Proper Sequencing: In order to avoid permanent damage to the power amplifier, the supply voltages must be sequenced. The proper power up sequence is VNEG, then VPOS, and then VDD. The proper power down sequence is remove VDD, then VPOS, and then VNEG.

ABSOLUTE MAXIMUM RATINGS

PARAMETER		TEST CONDITION	MIN	MAX	UNIT
V _{DD}	DC supply voltage		0	+8	V
V _{POS}			0	5.5	
V _{NEG}			-5.5	0	
I _{DD}	Current consumption			700	Ma
P _{IN}	RF input power			20	dBm
T _J	Junction temperature			175	°C
P _D	Power dissipation			5.5	W
	Digital input pins		-0.3	5.5	
Θ _{jc}	Thermal resistance junction to case ⁽¹⁾			20	°C/W
T _{stg}	Storage temperature		-40	+105	°C
T _{op}	Operating temperature	Maximum case temperature derate for PCB thermal resistance	-40	+85	°C
	Lead temperature	40 sec maximum		220	°C

(1) Thermal resistance is junction to case assuming thermal pad with 25 thermal vias under package metal base. See recommended layout [Figure 11](#) and application note RA1005 for more detail.

DC CHARACTERISTICS

PARAMETER		CONDITIONS	MIN	TYP	MAX	UNIT
V _{DD}	VDD supply voltage			7	7.35	V
I _{DD}	VDD supply current	PACNTRL = High, VDD = 7 V, 25°C		600	700	mA
V _{NEG}	Negative supply voltage		-5.25	-5	-4.75	V
I _{NEG}	Negative supply current			15	25	mA
V _{POS}	Positive supply digital voltage		4.75	5	5.25	V
I _{POS}	Positive supply digital current			25	50	mA
V _{IH}	Input high voltage		2.5		5	V
V _{IL}	Input low voltage				0.8	V
I _{IH}	Input high current				300	μA
I _{IL}	Input low current				-50	μA

POWER AMPLIFIER CHARACTERISTICS

V_{DD} = 7 V, I_{DD} = 600 mA, V_{POS} = 5 V, V_{NEG} = -5 V, PAGAIN0 = 1, PAGAIN1 = 1, PACNT = 1, T = 25°C, unless otherwise stated

PARAMETER		TEST CONDITIONS	MIN	TYP	MAX	UNIT
F	Frequency		2100		2700	MHz
G	Gain		26	30	36	dB
G _{HG}	Gain flatness full band	F = 2100 MHz to 2700 MHz		3	5	
G _{NB}	Gain flatness / 2 MHz				0.2	
OP-1dB	Output power at 1-dB compression		30	31.5		dBm
OIP3	Output third order intercept point		40	52		dB
	Gain step size 1st step	PAGAIN0 = Low, PAGAIN1 = High	15	16	17	
	Gain step size 2nd step	PAGAIN0 = Low, PAGAIN1 = Low	30	32	34	
V _{det}	Detector voltage output, differential (DETP-DETN)	At Pout = 27 ±0.75 dBm, F = 2100 to 2700 MHz at 25°C		150		mV
	Detector accuracy vs temperature	F=2500 MHz, -30°C to 75°C		±0.75		dB
t _{STEP}	Gain step response time			1	5	μS

POWER AMPLIFIER CHARACTERISTICS (continued)

$V_{DD} = 7\text{ V}$, $I_{DD} = 600\text{ mA}$, $V_{POS} = 5\text{ V}$, $V_{NEG} = -5\text{ V}$, $P_{GAIN0} = 1$, $P_{GAIN1} = 1$, $P_{ACNT} = 1$, $T = 25^\circ\text{C}$, unless otherwise stated

PARAMETER		TEST CONDITIONS	MIN	TYP	MAX	UNIT
$P_{ON/OFF}$	On to off power ratio	Max Gain to gain with $P_{ACNT} = \text{Low}$	35			dB
NF_{HG}	Noise figure, max gain	$P_{GAIN0} = \text{High}$, $P_{GAIN1} = \text{High}$		6	7	
NF_{LG}	Noise figure min gain	$P_{GAIN} = \text{Low}$, $P_{GAIN1} = \text{Low}$			20	
S_{12}	Reverse isolation		30			
S_{11}	Input return loss	$Z = 50\ \Omega$	-10	-12		
S_{22}	Output return loss	$Z = 50\ \Omega$		-8		

TYPICAL PERFORMANCE

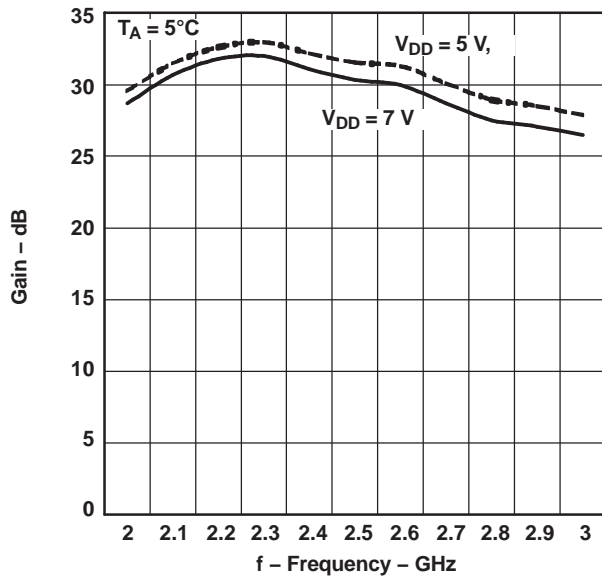

Figure 2. Gain vs Frequency

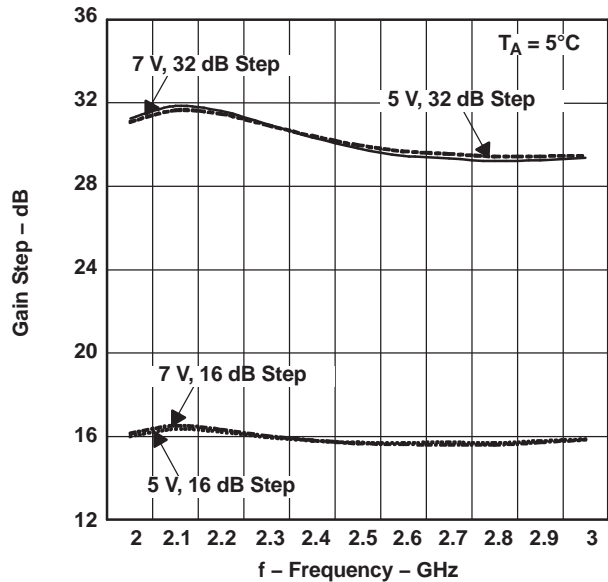

Figure 3. Gain Control

TYPICAL PERFORMANCE (continued)

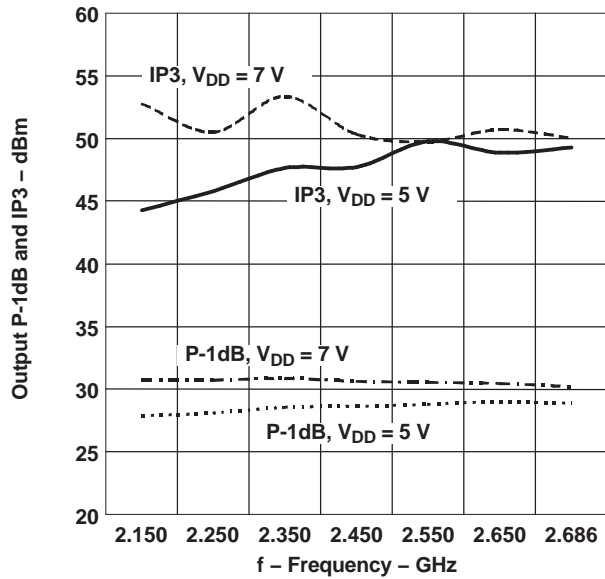

Figure 4. Output P-1 dB and IP3

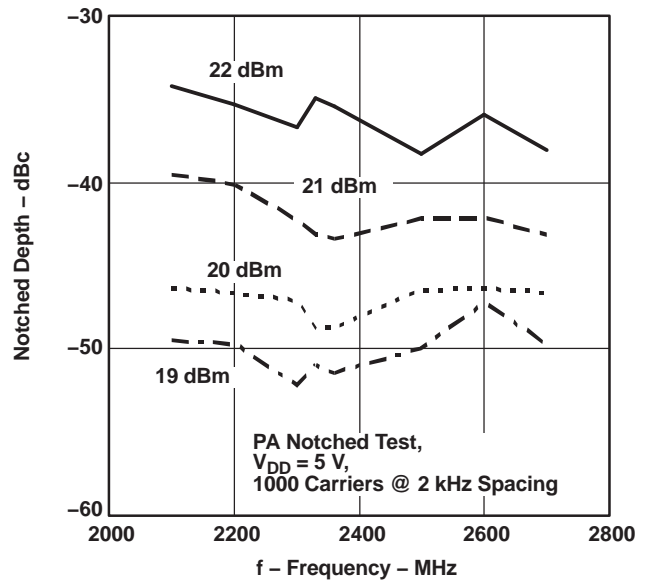

Figure 5. PA Notched Test ($V_{DD} = 5\text{ V}$)

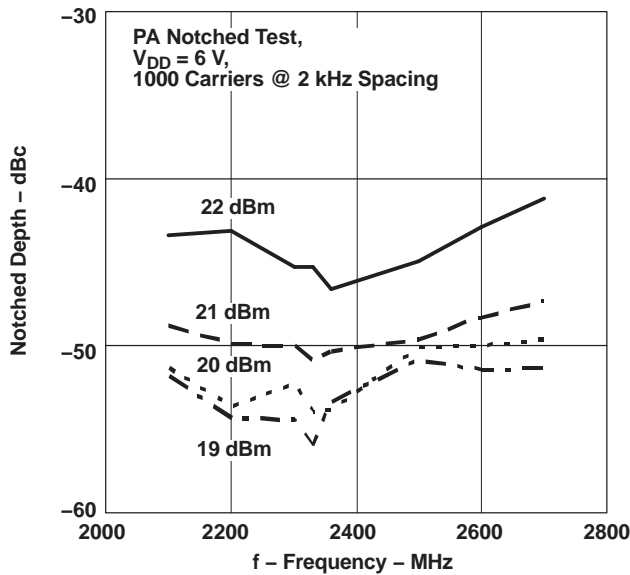

Figure 6. PA Notched Test ($V_{DD} = 6\text{ V}$)

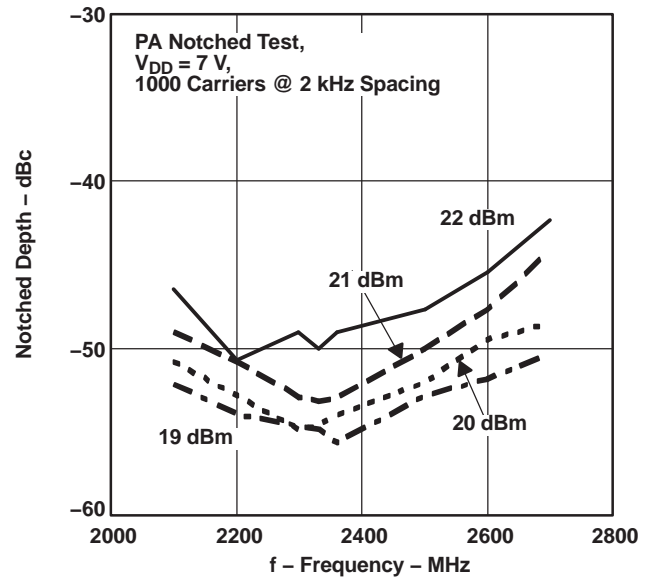

Figure 7. PA Notched Test ($V_{DD} = 7\text{ V}$)

TYPICAL PERFORMANCE (continued)

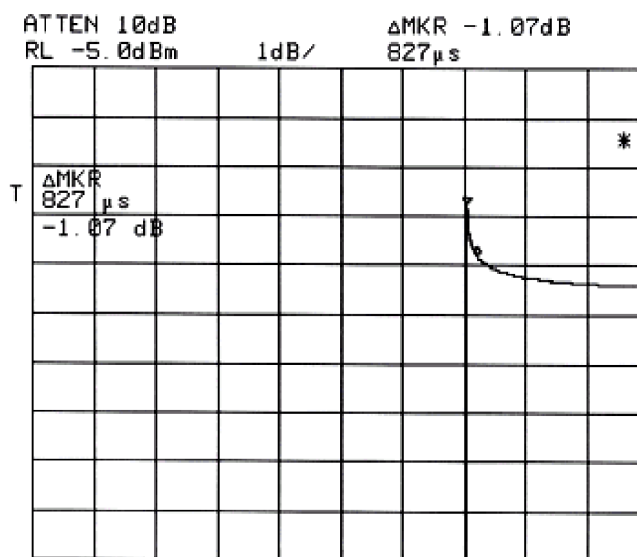
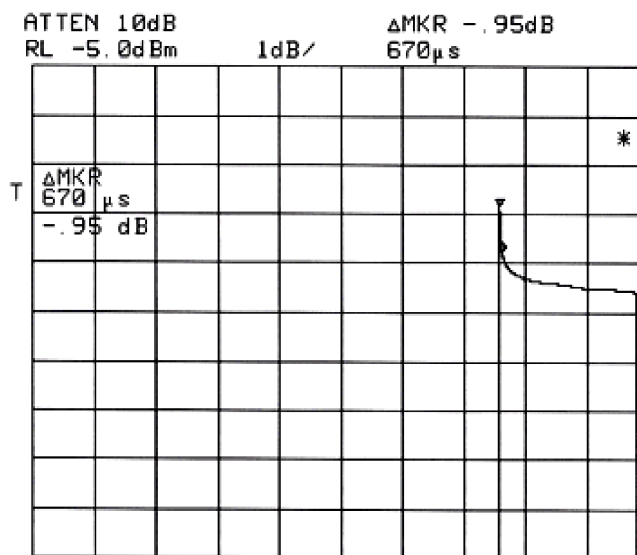

Figure 8. Pulse Droop - RF Output With PACNT Pulsed and 20% Duty Cycle

APPLICATION INFORMATION

Figure 9. Package Drawing

A typical application schematic is shown in Figure 10 and a mechanical drawing of the package outline (LPCC Quad 5 mm x 5 mm, 32-pin) is shown in Figure 9.

The recommended PCB layout mask is shown in Figure 11, along with recommendations on the board material Table 2 and construction Figure 12.

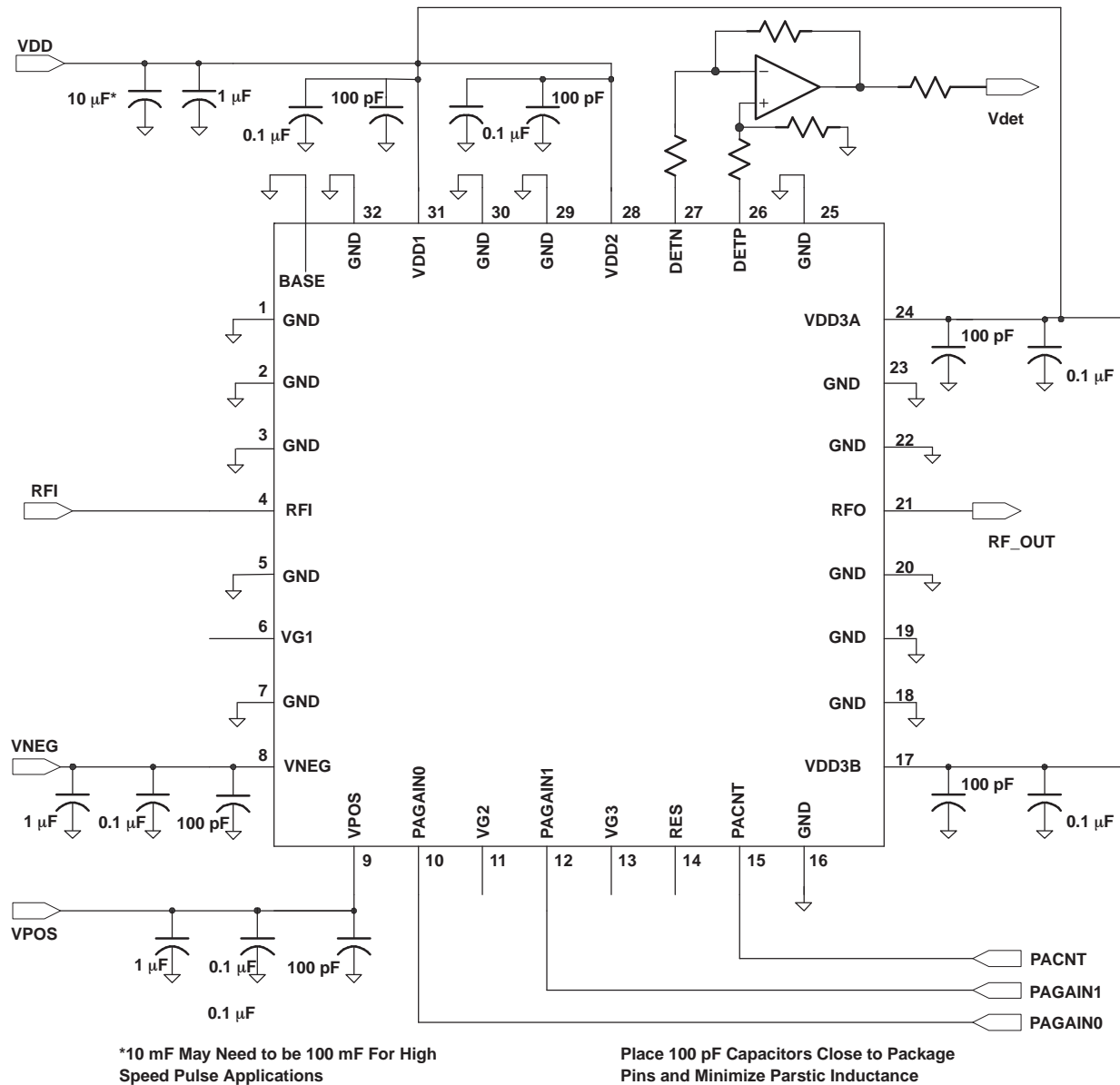

Figure 10. Recommended TRF1123 Application Schematic

Table 2. PCB Recommendations

Board Material	FR4
Board Material Core Thickness	10 mil
Copper Thickness (starting)	1 oz

Table 2. PCB Recommendations (continued)

Prepreg Thickness	8 mil
Recommended Number of Layers	4
Via Plating Thickness	0.5 oz
Final Plate	White immersion tin
Final Board Thickness	33-37 mil

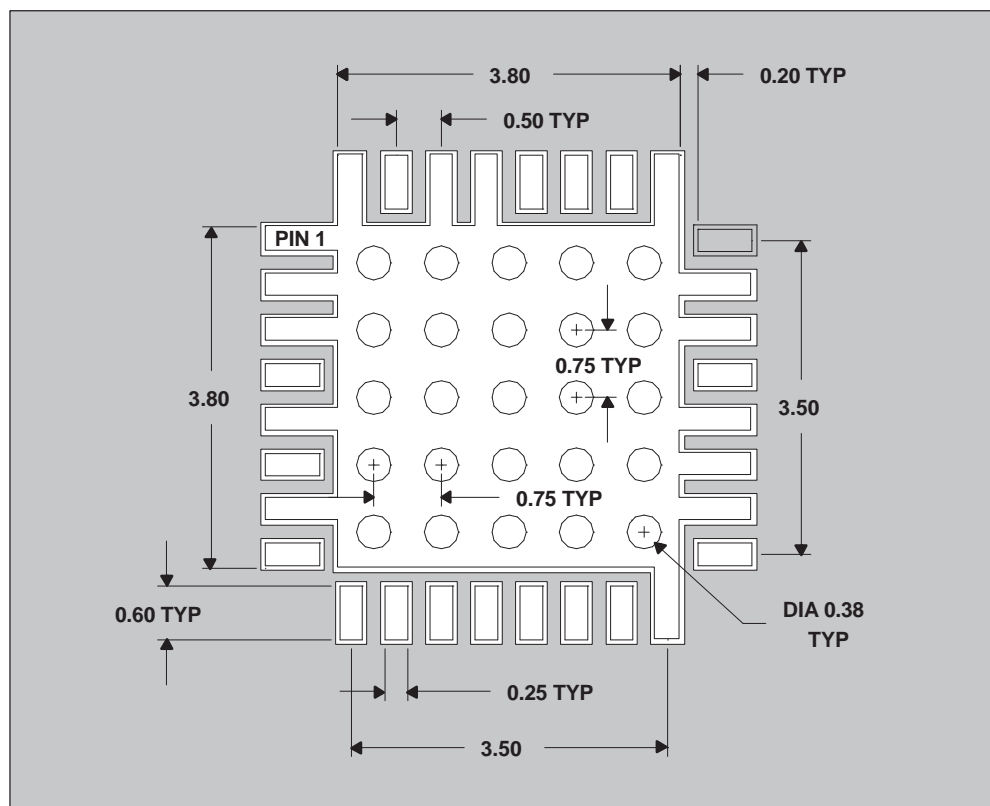

SOLDER MASK: NO SOLDERMASK UNDER CHIP, ON LEAD PADS OR ON GROUND CONNECTIONS.

25 VIA HOLES, EACH 0.38 mm.

DIMENSIONS in mm

Figure 11. Recommended Pad Layout

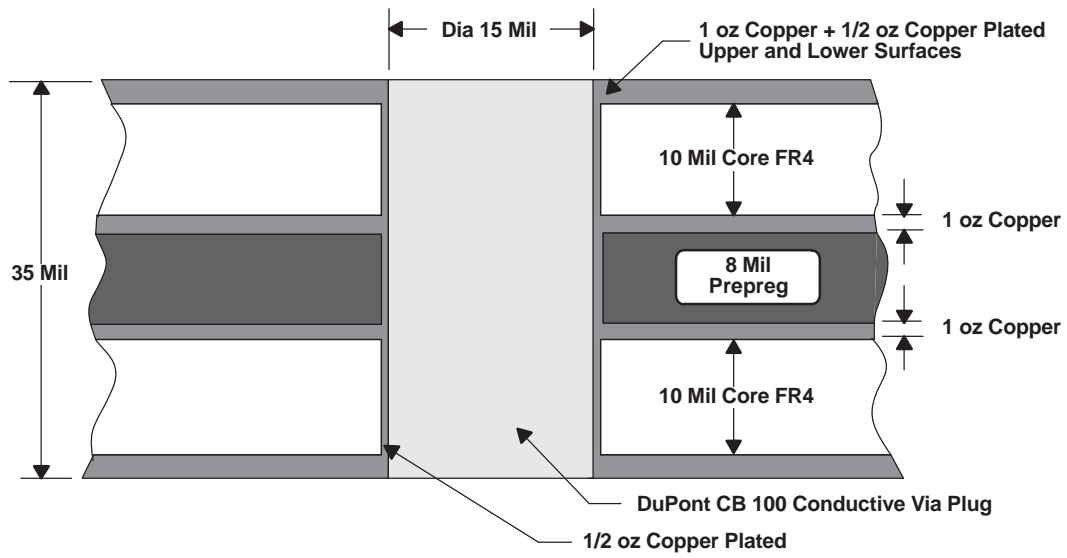

Figure 12. PCB Via Cross Section

PACKAGING INFORMATION

Orderable Device	Status ⁽¹⁾	Package Type	Package Drawing	Pins	Package Qty	Eco Plan ⁽²⁾	Lead/Ball Finish	MSL Peak Temp ⁽³⁾
TRF1123IRTMR	ACTIVE	QFN	RTM	32	3000	Green (RoHS & no Sb/Br)	CU SN	Level-3-260C-168 HR
TRF1123IRTMRG3	ACTIVE	QFN	RTM	32	3000	Green (RoHS & no Sb/Br)	CU SN	Level-3-260C-168 HR
TRF1123IRTMT	ACTIVE	QFN	RTM	32	250	Green (RoHS & no Sb/Br)	CU SN	Level-3-260C-168 HR
TRF1123IRTMTG3	ACTIVE	QFN	RTM	32	250	Green (RoHS & no Sb/Br)	CU SN	Level-3-260C-168 HR

⁽¹⁾ The marketing status values are defined as follows:

ACTIVE: Product device recommended for new designs.

LIFEBUY: TI has announced that the device will be discontinued, and a lifetime-buy period is in effect.

NRND: Not recommended for new designs. Device is in production to support existing customers, but TI does not recommend using this part in a new design.

PREVIEW: Device has been announced but is not in production. Samples may or may not be available.

OBSOLETE: TI has discontinued the production of the device.

⁽²⁾ Eco Plan - The planned eco-friendly classification: Pb-Free (RoHS), Pb-Free (RoHS Exempt), or Green (RoHS & no Sb/Br) - please check <http://www.ti.com/productcontent> for the latest availability information and additional product content details.

TBD: The Pb-Free/Green conversion plan has not been defined.

Pb-Free (RoHS): TI's terms "Lead-Free" or "Pb-Free" mean semiconductor products that are compatible with the current RoHS requirements for all 6 substances, including the requirement that lead not exceed 0.1% by weight in homogeneous materials. Where designed to be soldered at high temperatures, TI Pb-Free products are suitable for use in specified lead-free processes.

Pb-Free (RoHS Exempt): This component has a RoHS exemption for either 1) lead-based flip-chip solder bumps used between the die and package, or 2) lead-based die adhesive used between the die and leadframe. The component is otherwise considered Pb-Free (RoHS compatible) as defined above.

Green (RoHS & no Sb/Br): TI defines "Green" to mean Pb-Free (RoHS compatible), and free of Bromine (Br) and Antimony (Sb) based flame retardants (Br or Sb do not exceed 0.1% by weight in homogeneous material)

⁽³⁾ MSL, Peak Temp. -- The Moisture Sensitivity Level rating according to the JEDEC industry standard classifications, and peak solder temperature.

Important Information and Disclaimer:The information provided on this page represents TI's knowledge and belief as of the date that it is provided. TI bases its knowledge and belief on information provided by third parties, and makes no representation or warranty as to the accuracy of such information. Efforts are underway to better integrate information from third parties. TI has taken and continues to take reasonable steps to provide representative and accurate information but may not have conducted destructive testing or chemical analysis on incoming materials and chemicals. TI and TI suppliers consider certain information to be proprietary, and thus CAS numbers and other limited information may not be available for release.

In no event shall TI's liability arising out of such information exceed the total purchase price of the TI part(s) at issue in this document sold by TI to Customer on an annual basis.

RTM (S-PQFP-N32)

PLASTIC QUAD FLATPACK

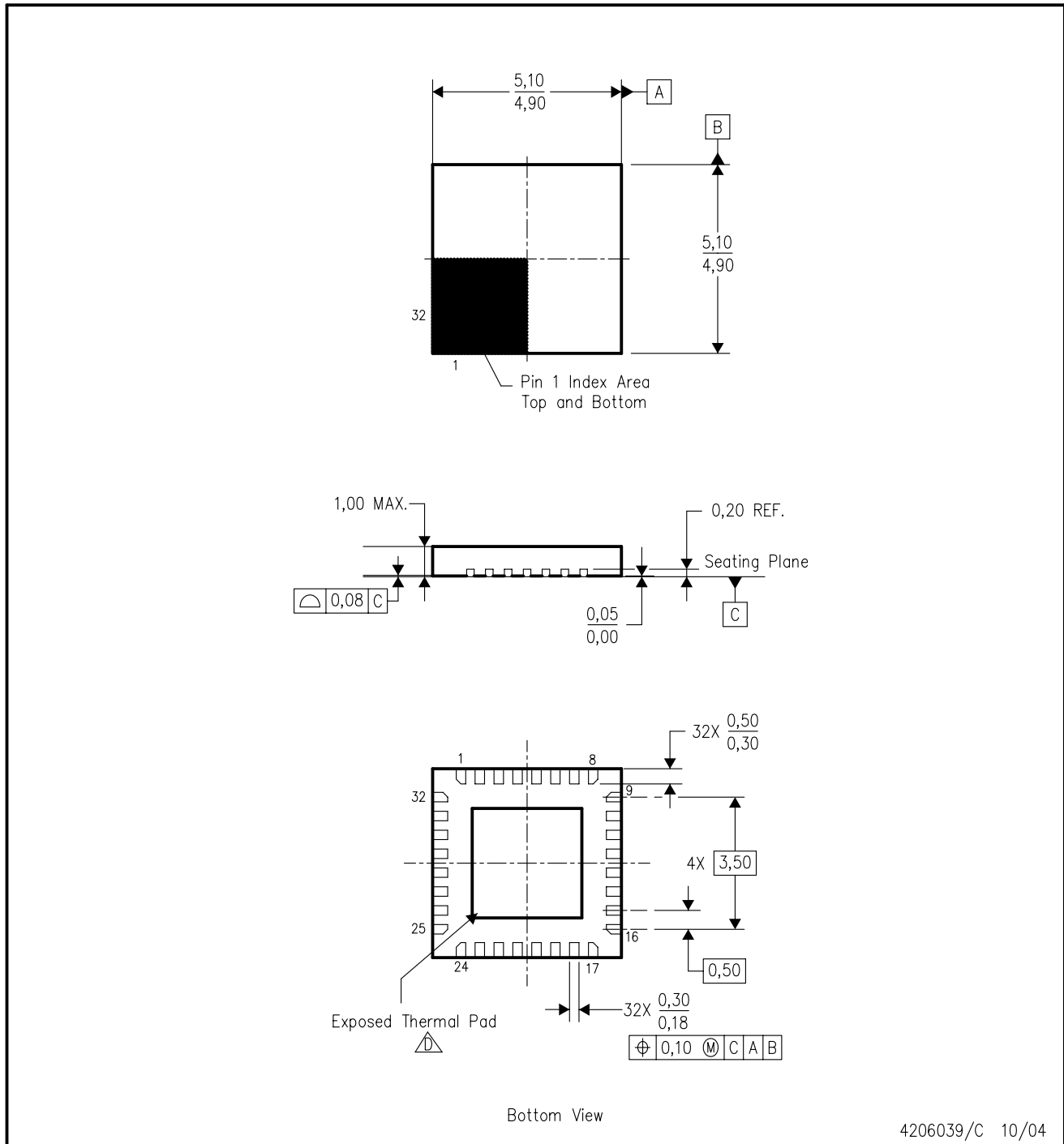

- NOTES:
- A. All linear dimensions are in millimeters.
 - B. This drawing is subject to change without notice.
 - C. QFN (Quad Flatpack No-Lead) Package configuration.
 -  The Package thermal pad must be soldered to the board for thermal and mechanical performance. See product data sheet for details regarding the exposed thermal pad dimensions.
 - E. Package complies to JEDEC MO-220.

IMPORTANT NOTICE

Texas Instruments Incorporated and its subsidiaries (TI) reserve the right to make corrections, modifications, enhancements, improvements, and other changes to its products and services at any time and to discontinue any product or service without notice. Customers should obtain the latest relevant information before placing orders and should verify that such information is current and complete. All products are sold subject to TI's terms and conditions of sale supplied at the time of order acknowledgment.

TI warrants performance of its hardware products to the specifications applicable at the time of sale in accordance with TI's standard warranty. Testing and other quality control techniques are used to the extent TI deems necessary to support this warranty. Except where mandated by government requirements, testing of all parameters of each product is not necessarily performed.

TI assumes no liability for applications assistance or customer product design. Customers are responsible for their products and applications using TI components. To minimize the risks associated with customer products and applications, customers should provide adequate design and operating safeguards.

TI does not warrant or represent that any license, either express or implied, is granted under any TI patent right, copyright, mask work right, or other TI intellectual property right relating to any combination, machine, or process in which TI products or services are used. Information published by TI regarding third-party products or services does not constitute a license from TI to use such products or services or a warranty or endorsement thereof. Use of such information may require a license from a third party under the patents or other intellectual property of the third party, or a license from TI under the patents or other intellectual property of TI.

Reproduction of information in TI data books or data sheets is permissible only if reproduction is without alteration and is accompanied by all associated warranties, conditions, limitations, and notices. Reproduction of this information with alteration is an unfair and deceptive business practice. TI is not responsible or liable for such altered documentation.

Resale of TI products or services with statements different from or beyond the parameters stated by TI for that product or service voids all express and any implied warranties for the associated TI product or service and is an unfair and deceptive business practice. TI is not responsible or liable for any such statements.

Following are URLs where you can obtain information on other Texas Instruments products and application solutions:

Products

Amplifiers	amplifier.ti.com
Data Converters	dataconverter.ti.com
DSP	dsp.ti.com
Interface	interface.ti.com
Logic	logic.ti.com
Power Mgmt	power.ti.com
Microcontrollers	microcontroller.ti.com
Low Power Wireless	www.ti.com/lpw

Applications

Audio	www.ti.com/audio
Automotive	www.ti.com/automotive
Broadband	www.ti.com/broadband
Digital Control	www.ti.com/digitalcontrol
Military	www.ti.com/military
Optical Networking	www.ti.com/opticalnetwork
Security	www.ti.com/security
Telephony	www.ti.com/telephony
Video & Imaging	www.ti.com/video
Wireless	www.ti.com/wireless

Mailing Address: Texas Instruments
Post Office Box 655303 Dallas, Texas 75265