

DATA SHEET



GPES203B

Easy-to-use SOUNDPLUS

Jan. 05, 2009

Version 1.1

GENERALPLUS TECHNOLOGY INC. reserves the right to change this documentation without prior notice. Information provided by GENERALPLUS TECHNOLOGY INC. is believed to be accurate and reliable. However, GENERALPLUS TECHNOLOGY INC. makes no warranty for any errors which may appear in this document. Contact GENERALPLUS TECHNOLOGY INC. to obtain the latest version of device specifications before placing your order. No responsibility is assumed by GENERALPLUS TECHNOLOGY INC. for any infringement of patent or other rights of third parties which may result from its use. In addition, GENERALPLUS products are not authorized for use as critical components in life support devices/systems or aviation devices/systems, where a malfunction or failure of the product may reasonably be expected to result in significant injury to the user, without the express written approval of Generalplus.

Table of Contents

	<u>PAGE</u>
TABLE OF CONTENTS	2
EASY-TO-USE SOUNDPLUS	3
1. GENERAL DESCRIPTION	3
2. BLOCK DIAGRAM	3
3. FEATURES	3
4. SIGNAL DESCRIPTIONS	4
4.1. PAD ASSIGNMENT	4
5. FUNCTIONAL DESCRIPTIONS	5
5.1. INSTRUCTION SETS	5
5.2. I/O DESCRIPTION	5
5.3. PROGRAM STRUCTURE OVERVIEW	5
5.3.1. Definition area	5
5.3.2. Entry point (Label)	6
6. GPES II PROGRAMMING TOOL	7
7. ELECTRICAL SPECIFICATIONS	8
7.1. ABSOLUTE MAXIMUM RATINGS	8
7.2. DC CHARACTERISTICS	8
7.3. (3VOLT) R RELATIVE FOSC TABLE (THE TABLE IS ONLY FOR REFERENCE)	8
8. APPLICATION CIRCUIT	9
9. PACKAGE/PAD LOCATIONS	10
9.1. ORDERING INFORMATION	10
10. DISCLAIMER	11
11. REVISION HISTORY	12

Easy-to-use SOUNDPLUS

1. GENERAL DESCRIPTION

The easy-to-use SOUNDPLUS II (GPESII) is an enhancement of easy-to-use SOUNDPLUS (GPES). Many features, such as Infrared Red (IR) and I/O pull-high option, have been added to strengthen capability and flexibility. The GPESII inherits all GPES features and of course including the most remarkable feature, simple programming structure. Programmers can bring the products to markets rapidly and increase productivity efficiently.

With only twelve instructions and six registers, GPES II is capable of driving sophisticated functions and processing enormous acoustic data with simple program structure. The unique advanced ADPCM speech algorithm can deliver high quality and realistic sound effects. For other features, each GPES II equips four programmable I/Os, PWM output, and five LED flash alternations. The high cost/performance ratio makes GPESII the simplest and the most powerful microprocessor in the industry for your products.

The GPES203B, one of the GPES II families, stores up to 3 seconds of acoustic data (@ 6.0KHz sample rate). We will introduce it in the following sections.

2. BLOCK DIAGRAM

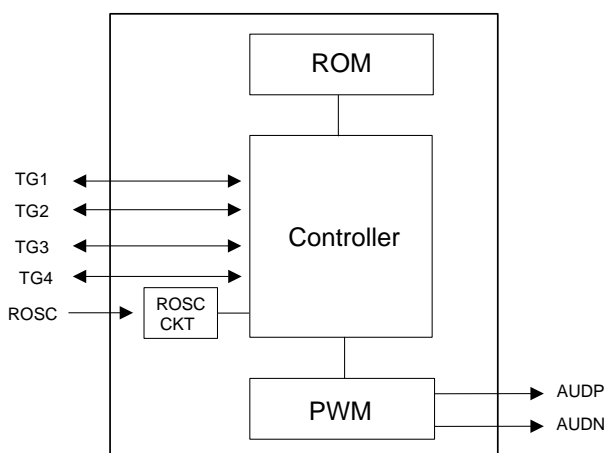

3. FEATURES

- 12KB ROM SIZE
- Programmable speech synthesizer
- Operating voltage:
 - 1.9V - 5.5V for speed of 4.0MHz
 - 3.6V - 5.5V for speed of 6.0MHz
- Approximate 3 seconds speech length @ 6.0KHz sample rate
- 4 programmable I/O pins
- Programmable power on initialization
- 256 entries available
- Mask option: pull-high/floating resistor for 4 programmable I/Os
- Flexible functions:
 - Individual I/O configuration with pull-high option
 - Easy speech equation
 - Local repeat setting
 - Output frequency and LED flash type setting
 - Interrupt or non-interrupt of rising/falling edge for each trigger
 - Eight programmable playing modes:
 - One shot
 - Level hold
 - Single-cycle level hold
 - Complete-cycle level hold
 - Sequence
 - Level-Auto
 - Random
 - Non-retrigger
- Each voice section provides
 - Programmable sampling frequency
 - 2K to 10K for 4.0MHz operating clock
 - 2K to 15K for 6.0MHz operating clock
 - Five LED flash type: On, Off, Alternatively, Synchronous, Volume-controlled
- A pair of PWM outputs
- Watchdog function
- Infrared Red (IR) communication Function
- Play Speech with tags. Seven different tags are available

4. SIGNAL DESCRIPTIONS

Mnemonic	PIN No.	Type	Description
TG4 - 3	6 - 7	I/O	Trigger input pins/ Output signals pins / LED driver
TG2 - 1	8 - 9	I/O	Trigger input pins/ Output signals pin
AUDP, AUDN	5, 2	O	PWM outputs for speaker
ROSC	11	I	R Oscillator input
VDD	1	P	Positive supply for logic and I/O pins
AVDD	3	P	Positive supply for PWM
VSS	10	P	Ground reference for logic and I/O pins
AVSS	4	P	Ground reference for PWM

Legend: I = Input, O = Output, P = Power

4.1. PAD Assignment

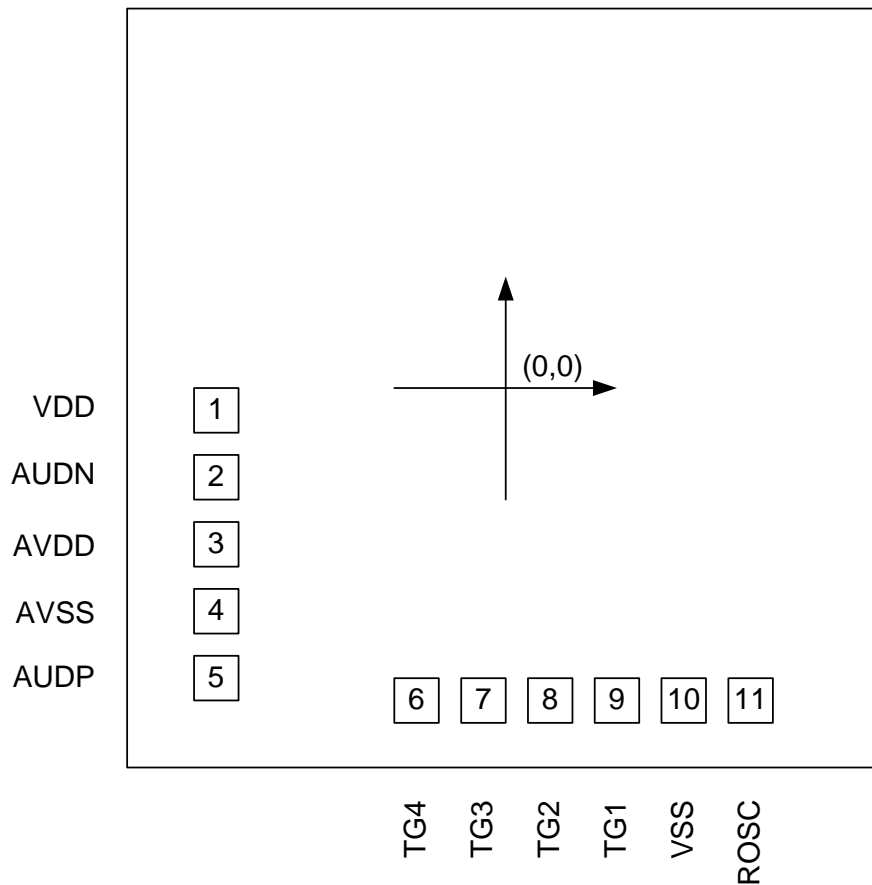

This IC substrate should be connected to VSS

Note1: To ensure IC functions properly, bond all VDD and VSS pins.

Note2: The 0.1µF capacitor between VDD and VSS should be placed to IC as closed as possible.

5.FUNCTIONAL DESCRIPTIONS

5.1. Instruction Sets

Twelve instructions are *LD, JP, LSR, ADD, SUB, AND, ORR, EOR, END, IRSend, RxEnable, and RxDisable*. “LD” means LOAD and “JP” indicates JUMP. “LSR” shifts a register’s content one bit to the right. “ADD” and “SUB” are addition and subtraction. “AND”, “ORR” and “EOR” are logical operations which mean AND, OR and, Exclusive OR respectively. “END” ends program and enters into sleep mode for power saving purpose. The IRSend, RxEnable and RxDisable are three commands for IR functions. For more information on how to apply these commands, please refer to GPES II Programming Guide.

5.2. I/O Description

GPES II small series has the following I/O pins: TG1, TG2, TG3, and TG4. All these pins are programmable and TG3, TG4 can be shared with LED drive pins.

PIN	Configuration
TG1	I/O
TG2	I/O
TG3	I/O (shared with LED pin)
TG4	I/O (shared with LED pin)

5.3. Program Structure Overview

As mentioned above, the GPES II program structure is very simple. The following description is an overview of GPES II program structure. For more information about GPES II programming style, please refer to GPES II Programming Guide.

5.3.1. Definition area

The beginning of a program is the **Definition Area** that defines many declarations before Initialization, e.g. IC body, variable, frequency, debounce time and low voltage reset option.

5.3.1.1. IC body

The first element defined in a program is a GPES II body.

Example:

```

SPES203B      ;select SPES203B
EXT_CLK_4M
Freq4         ;Set default speech
              ;sample frequency to 7.8K
...
POI:
...
...

```

5.3.1.2. Debounce

A key debounce time can be defined in Definition Area. The range of debounce time is 5ms - 35ms.

5.3.1.3. Variable

A variable can be defined by adding a “#define” in front of a variable. A variable can be the combination of numbers and characters, but not underscore.

Variable Syntax:

```
#define VariableName <Register | NUM>
```

Example1:

```
#define var R0 ;define var as R0
```

Example2:

```
#define const 8 ;define const as 8
```

5.3.1.4. External clock

Users can define one external clock out of the following selections in a program. This option must be defined in definition area.

```

EXT_CLK_3M; (3.0MHz)
EXT_CLK_4M; (4.0MHz)
EXT_CLK_6M; (6.0MHz)

```

5.3.1.5. Infrared Red (IR) Function

Some IR parameters must be defined in Definition Area before using IR function. We will only introduce the commands here. For more details on how to use these commands in your program, please refer to GPES II Programming Guide.

- 1). IR_ID NUM; where NUM = 0, 1, 2 or 3
Setup an IR ID. When IR_ID is given, the IR receiver module will be automatically included in the program.
- 2). SetRxPin NUM
Setup the IR receive pin.
; Where NUM = 0, 1, 2, or 3; default = 3 (TG4)
- 3). SetTxPin NUM
Setup the IR transmitter pin.
; Where NUM = 0, 1, 2, or 3; default = 2 (TG3) for small body
- 4). SetRxPowerPin NUM
Setup IR receiver power control pin
; Where NUM = 0, 1, 2, or 3 for small body.

5.3.2. Entry point (Label)

The essence utilized in GPES II program is the ENTRY POINT. Each trigger pin is assigned an entry point. Programmers can also define a label (ID) for an entry point. A label can be the combinations of number and character, but not underscore. In addition, a label cannot start with a number.

Example

```
SpeechLoop:
    Sound1+Sound2
    JP SpeechLoop
```

When a pin is triggered, the program jumps to its corresponding entry point and starts executing. The entry points are fixed numbers. For instance, "0" is the entry point of TG1 when 1→0. "1" is the entry point of TG2 when 1→0. Programmers can either use Entry Point ID or Entry Point Abbreviator to express an entry point. A summary of entry point for each trigger pin is as follows:

Entry Point	Entry Point Abbreviator	Status
32	POI	Power on initialization
0	TG1F	TG1 1→0 (falling)
1	TG2F	TG2 1→0 (falling)
2	TG3F	TG3 1→0 (falling)
3	TG4F	TG4 1→0 (falling)
4	TG1R	TG1 0→1 (rising)
5	TG2R	TG2 0→1 (rising)
6	TG3R	TG3 0→1 (rising)
7	TG4R	TG4 0→1 (rising)
8 - 254 (except 32)	User-Defined entry point or label	User-Defined
255	Timer event	User-Defined

Example:

An example is introduced here. Also, all words after semi-colon (;) are for comments only.

```
SPES203B          ;body defined
EXT_CLK_4M

POI:
    LD EN, 0x00
    (4000)_3
    LD EN, 0x 03  ;enable TG1 falling and
                  ;TG2 falling

END

TG1F:
    Sound1        ;when TG1 changes from
                  ;1→0 (High→Low),
                  ;sound1 is played

END              ;Sleep

TG2F:
    Sound2        ;when TG2 changes from
                  ;1→0, sound2 is played

END              ;Sleep
```

6.GPES II PROGRAMMING TOOL

GENERALPLUS provides a user-friendly programming tool that allows programmers to write, edit, compile and debug programs. Simply speaking, all projects can be accomplished in GPES II programming tool, from coding to debugging and compiling, no other tools needed. Every step is done within the single window.

GPES II Programming Tool should be executed under Windows 95, Windows 98 and Windows 2000. GENERALPLUS provides a complete user's manual for GPES II Programming Tool, please refer to GPES II Programming Guide.

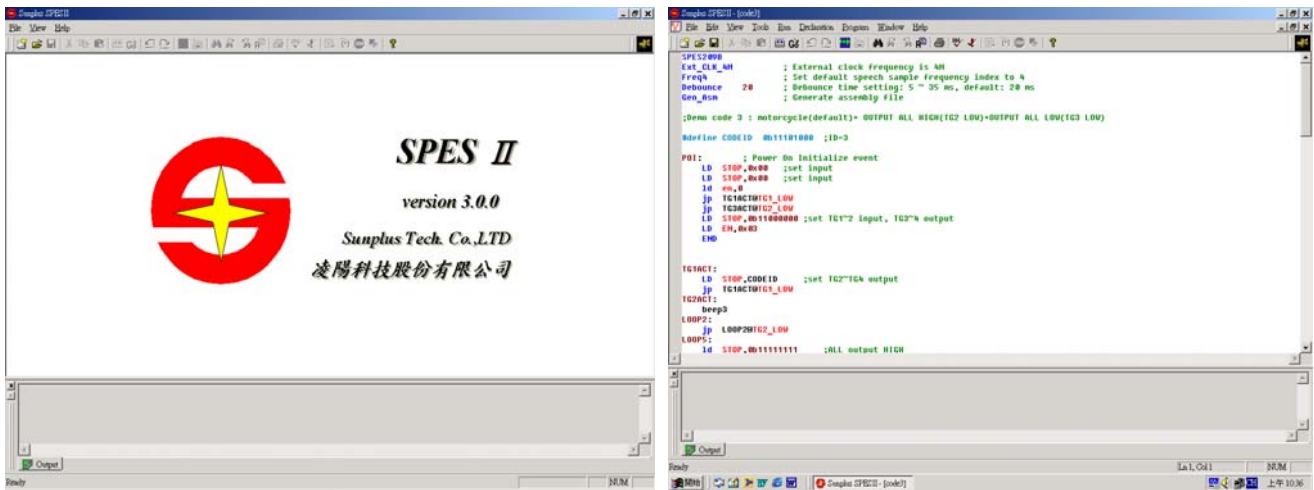

7. ELECTRICAL SPECIFICATIONS

7.1. Absolute Maximum Ratings

Characteristics	Symbol	Ratings
DC Supply Voltage	V_+	< 7.0V
Input Voltage Range	V_{IN}	-0.5V to $V_+ + 0.5V$
Operating Temperature	T_A	0°C to +60°C
Storage Temperature	T_{STO}	-50°C to +150°C

Note: Stresses beyond those given in the Absolute Maximum Rating table may cause operational errors or damage to the device. For normal operational conditions see AC/DC Electrical Characteristics.

7.2. DC Characteristics

Characteristics	Symbol	Limit			Unit	Test Condition
		Min.	Typ.	Max.		
Operating Voltage	VDD	1.9	-	5.5	V	-
TG4 - TG3 Output Current	I_{OL}	-	15	-	mA	VDD = 3.0V, $V_{OUT} = 0.4V$
	I_{OH}	-	3.5	-		VDD = 3.0V, $V_{OUT} = 2.0V$
TG2 - TG1 Output Current	I_{OL}	-	10	-	mA	VDD = 3.0V, $V_{OL} = 1.0V$
	I_{OH}	-	3.5	-		VDD = 3.0V, $V_{OH} = 2.0V$
Standby Current	I_{STBY}	-	-	2.0	μA	VDD = 3.0V
Operating Current	I_{OP}	-	1.7	-	mA	VDD = 3.0V, no load
PWM Output Current	I_{OL}	-	200	-	mA	VDD = 3.0V, $V_{OL} = 1.0V$
	I_{OH}	-	120	-		VDD = 3.0V, $V_{OH} = 2.0V$
Input Current of TG4 - TG1	I_{IN}	-	25	-	μA	VDD = 3.0V

7.3. (3volt) R Relative FOSC Table (the table is only for reference)

R(Kohm)	47K Ω	75K Ω	100K Ω
F _{osc} (MHz)	6	4	3

NOTE*: $F_{CPU} = F_{OSC} / 2$

8.APPLICATION CIRCUIT

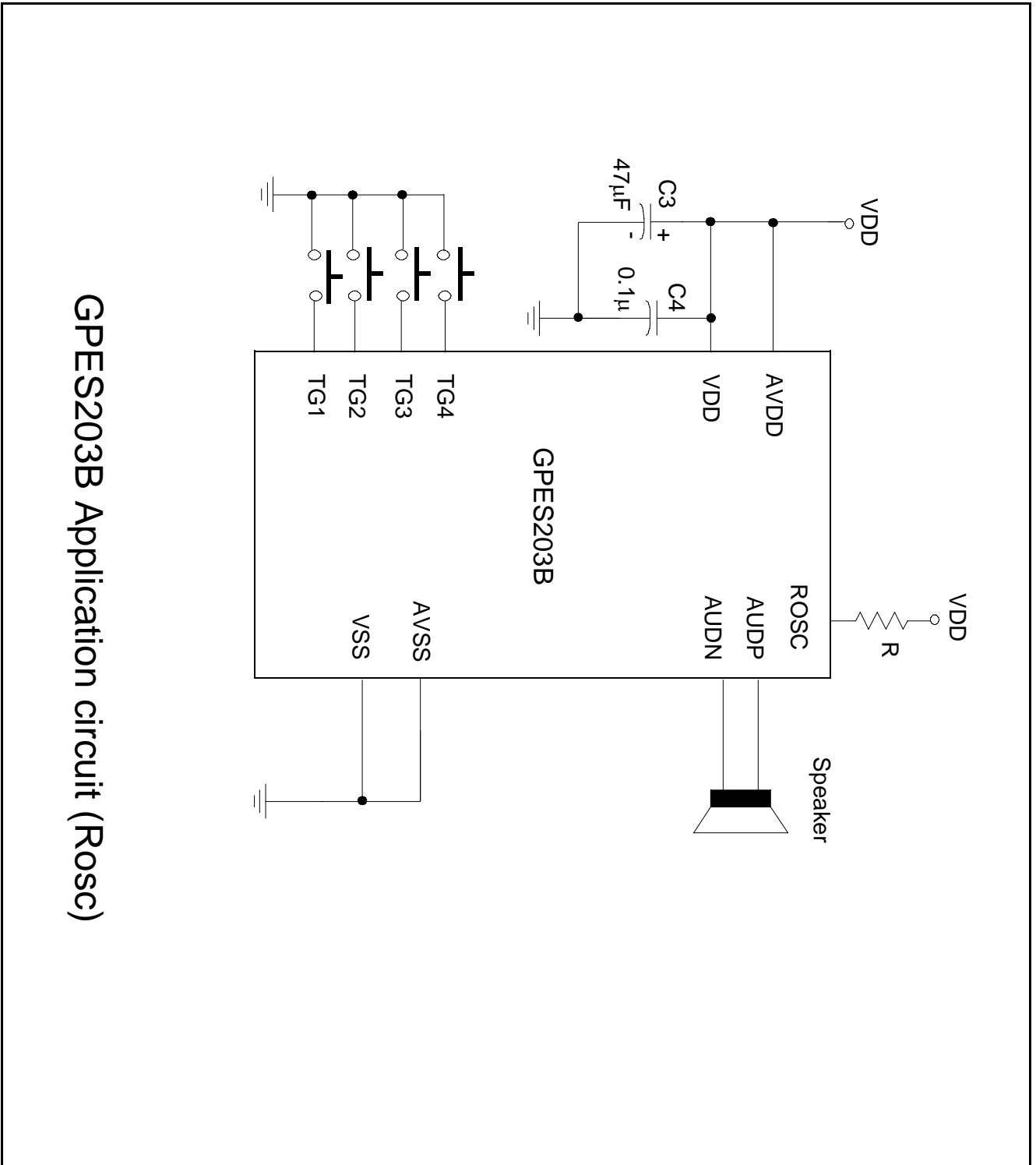

GPES203B Application circuit (Rossc)

9. PACKAGE/PAD LOCATIONS

9.1. Ordering Information

Product Number	Package Type
GPES203B-NnnV-C	Chip form

Note1: Code number is assigned for customer.

Note2: Code number (N = A - Z or 0 - 9, nn = 00 - 99); version (V = A - Z).

10. DISCLAIMER

The information appearing in this publication is believed to be accurate.

Integrated circuits sold by Generalplus Technology are covered by the warranty and patent indemnification provisions stipulated in the terms of sale only. GENERALPLUS makes no warranty, express, statutory implied or by description regarding the information in this publication or regarding the freedom of the described chip(s) from patent infringement. FURTHERMORE, GENERALPLUS MAKES NO WARRANTY OF MERCHANTABILITY OR FITNESS FOR ANY PURPOSE. GENERALPLUS reserves the right to halt production or alter the specifications and prices at any time without notice. Accordingly, the reader is cautioned to verify that the data sheets and other information in this publication are current before placing orders. Products described herein are intended for use in normal commercial applications. Applications involving unusual environmental or reliability requirements, e.g. military equipment or medical life support equipment, are specifically not recommended without additional processing by GENERALPLUS for such applications. Please note that application circuits illustrated in this document are for reference purposes only.

11. REVISION HISTORY

Date	Revision #	Description	Page
JAN. 05, 2009	1.1	1. Modify 3 FEATURES. 2. Modify 8.2 DC Characteristics.	3 8
JAN. 09, 2006	0.1	Original Note: The GPES203B data sheet v1.0 is a continued version of SPES203B data sheet v0.3.	10